

Alpha MagnaTrack Product Manual



FEATURES & BENEFITS

NEW ZEALANDS FIRST AND ONLY SELF-CORRECTING AWNING SYSTEM

With our patented magnet technology, the Weathermaster Alpha MagnaTrack Awning is the only straight drop awning system in New Zealand that has a self-correcting feature which allows the fabric skin to effortlessly return into the channel should it ever become dislodged - minimising the extra time and labour required to go onsite for a service call.

To activate this feature, lower the awning as far down as it can go with the remote control and then raise the awning past the point of the fabric blowout. As the awning retracts, the magnets continually pull on the fabric, feeding it back inside the screen guide allowing the awning to be operated as usual.

PATENTED SELF TENSIONING MAGNETIC TRACK SYSTEM

The magnetic force in the track system allows the fabric to move while under wind pressure as it floats within the channel.

After the wind pressure subsides, the magnetic bond of the neodymium magnets will automatically re-tension the fabric back to its original appearance – a world first in functionality which goes far beyond what a standard zipped awning can do.

The Weathermaster Alpha MagnaTrack Awning (3.5m opening span width) has been independently tested to withstand wind pressures up to 185kph[^] by James Cook University's Cyclone Testing Station, making it New Zealand's strongest, wind tested, Straight Drop awning.

RARE EARTH NEODYMIUM MAGNETS

The technology behind the Alpha MagnaTrack Awning lies deep within its patented design. The side channels employ the use of Rare Earth Neodymium Magnets in both the side track and the adjustable track insert that hold the fabric.

These magnets are the strongest and most powerful magnets commercially available and on an average sized awning, provide over 100kg of magnetic force on each side keeping the fabric on the awning looking beautifully smooth, flat and taut.

*Per average blind drop of 2.4m

INTERNAL HEADBOX ROLLER BRUSH

There are two brushes located inside the headbox to prevent insects, spiders and wasps from getting inside the headbox and creating nests. The added benefit of the dual brush set up is that it helps to keep the fabric clean while the awning is being operated and increases its longevity.

ULTRAWIDE SPANS WITH PREMIUM SPECTRA FIBREGLASS SUNSCREEN FABRIC

The Weathermaster Alpha MagnaTrack Awning can accommodate widths up to 6.5 metres and drops of 4 metres and is exclusively available with our premium fibreglass fabric range - Weathermaster Spectra Fibreglass Sunscreen. This fabric range features a sophisticated twill weave with subtly elegant diagonal patterns and is available in both 3% and 1% openness in a range of contemporary colours.

KEDER INTERLOCK

Unlike a standard zip system, the Alpha MagnaTrack Awning uses a heavy duty Keder interlock system to attach the fabric within the awning. This allows for a more robust system which is less prone to failure compared to a zip system. The flexible PVC keder core is embedded in a highly durable Teflon® coated polyester and has a high tear strength to withstand the harsh New Zealand conditions.

HEAVY DUTY BOTTOM RAIL

The Alpha MagnaTrack Awning has a heavy duty bottom rail to allow for smooth and consistent operation while keeping the fabric looking flat. It also features an insect brush to reduce light gaps, insects, and debris from entering.

AUTOMATION

The largest and most trusted names in home automation are used with Weathermaster Window Coverings to power its vast product range. The Alpha MagnaTrack Awning is exclusively available with Somfy® motorisation. These are also available for the entire Alpha Awnings range providing convenience from a single control point.

FABRIC RANGE

SPECTRA SUNSCREEN

Weathermaster Spectra Sunscreen is a premium fibreglass range for the Weathermaster external fabric collection.

Constructed using a twill weaving technique that produces highly durable fabrics with elegant diagonal patterns. Weathermaster Spectra fibreglass Sunscreen is extremely robust and is suited for both residential and commercial applications.

STRENGTH AND STABILITY

Weathermaster Spectra Sunscreen's incredible strength and durability comes from its use of fibreglass yarn with Enduris Glass Core Technology. This is a combination of superior quality coatings, glass core yarns and innovative weaving techniques, allowing Weathermaster Spectra Fibreglass Sunscreen to be highly resistant to changes in temperature. Due to the nature of the fabric interlacing, the individual yarn can be packed more tightly together making the fabric stronger than a plain weave made from the same materials.

PERFORMANCE

Utilising Weathermaster Spectra Sunscreen on an external awning can eliminate up to 95% of solar heat penetration while allowing diffused light to pass through.

Light is evenly distributed through the fabric ensuring optimal contrast in the field of view preventing glare.

Spectra fabric range is made with Enduris™ Glass Core Technology, which is exceptionally fade resistant, rot resilient and offers excellent UV protection from the harsh New Zealand sun.

BEAUTY

Weathermaster Spectra Sunscreen features a sophisticated twill weave with subtly elegant diagonal patterns and is available in a range of contemporary colours. For an added touch of style, opt for a mélange mixed colour weave. The unique production process and the inherent characteristics of fibreglass fabric allows Weathermaster Spectra Sunscreen to hang beautifully straight, even after being left up for extended periods.

ECO FRIENDLY

While some fabrics in the market may contain synthetic petroleum-based compounds, the glass core yarns used in the Weathermaster Spectra Sunscreen range are derived from Silica, a naturally and renewable mineral element. Weathermaster Spectra Sunscreen is a recyclable product that meets certification requirements set by Oeko-Tex® for the exclusion of harmful substances as well as being GreenGuard® Gold certified to meet strict certification criteria for low Volatile Organic Compound (VOC) emissions and is acceptable for use in environments such as schools and healthcare facilities (IEQ-11).

This makes Weathermaster Spectra Sunscreen not only the best choice for your home but the best choice for the environment as well.

FABRIC TECHNICAL SPECIFICATIONS

COMPOSITION

3% Glass 41.5%, PVC 58.5%

1% Glass 41.5%, PVC 58.5%

FABRIC WEIGHT

1% 474 g/m2 +/- 5%

3% 544 g/m2 +/- 5%

FABRIC THICKNESS

1% 0.60mm +/- 0.10mm

3% 0.80mm +/- 0.10mm

BREAKING STRENGTH

1% 0 Warp 290daN, Weft 210daN +/- 5%

3% Warp 310daN, Weft 230daN +/- 5%

TEARING RESISTANCE

1% Warp 9.5daN, Weft 10daN +/- 5%

3% Warp 10daN, Weft 13daN +/- 5%

FABRIC STIFFNESS

1% 59MM +/- 5%

3% 72MM +/- 5%

WEAVE DIRECTION

Weathermaster Spectra Sunscreen has a front and back. Colour variation between front and back will appear in weaves with more than one yarn colour. The true pattern direction shows weave running from upper left to bottom right as shown below.

SOLAR OPTICAL GUIDE

SPECTRA SUNSCREEN 1%	SOLAR OPTICAL PROPERTIES			
	HEAT PROPERTIES			VISIBLE LIGHT PROPERTIES
COLOUR	TS	RS	AS	TL
GREY	5	21	74	2
GREY-BLACK	3	16	81	2
BLACK-GREY	1	10	89	1
BLACK	0	7	93	0

SPECTRA SUNSCREEN 3%	SOLAR OPTICAL PROPERTIES			
	HEAT PROPERTIES			VISIBLE LIGHT PROPERTIES
COLOUR	TS	RS	AS	TL
GREY	5	14	81	5
GREY-BLACK	4	13	83	4
BRONZE	5	9	86	5
LINEN	14	53	33	11
PEARL	7	40	53	6
BLACK-BRONZE	6	6	88	6
BLACK	3	5	92	3

SOLAR OPTICAL PROPERTIES GUIDE

TS	Heat Transmittance (%)
RS	Heat Reflectance (%)
AS	Heat Absorbance (%)
TL	Light Transmittance (%)

HARDWARE COLOUR OPTIONS

The Alpha MagnaTrack Awning has been designed to integrate seamlessly with the entire Weathermaster Alpha Awning range and is available in 7 colours which coordinate with the most popular Colorbond® and Dulux® colour palette.

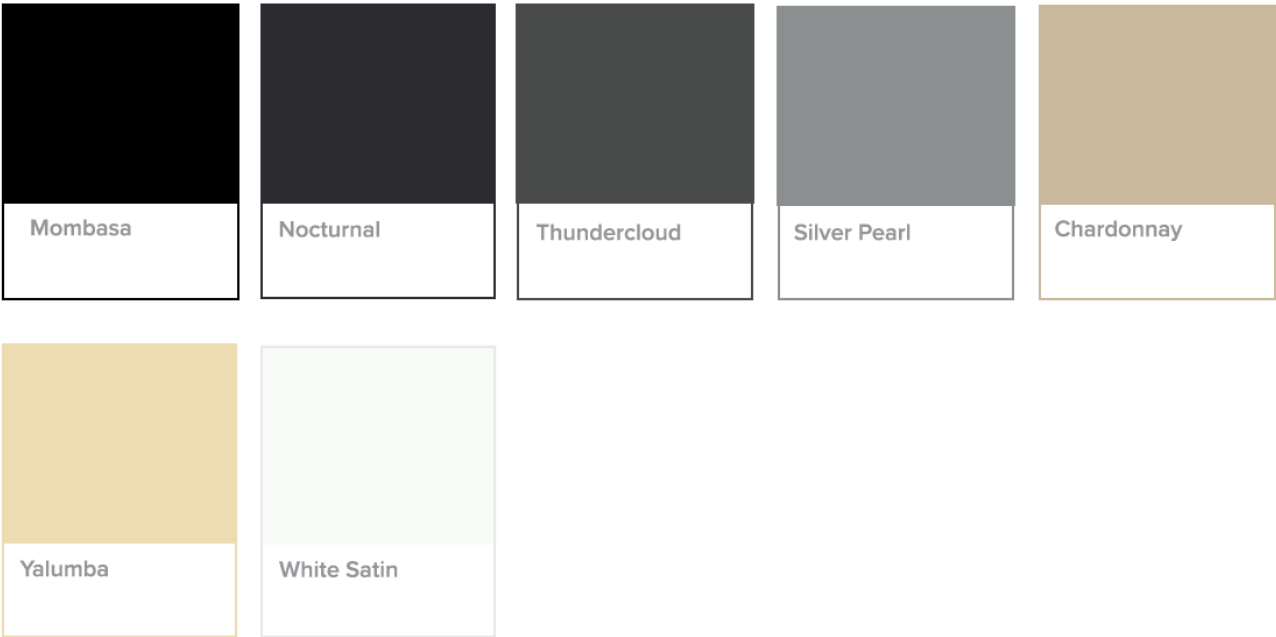

MAGNATRACK EXPLODED DIAGRAM

No	Part Code	Description
5	510121	UNIVERL ZAMACK BRT & LOCK RING
6		
7		
8		
9	709848	ALTUS 50 RTS 25/17 MOTOR
10		
11	709916 709915	CROWM 60MM OCTAGONAL TUBE WHEEL 60MM OCTAGONAL TUBE
12		
13	44.010.XXX 44.011.XXX 44.012.XXX	STANCE FIBREGLASS SKIN
14	42.421.855	POLY-ABS SPLINE TUBE 6mm
15	52.000.063	UNIVERSAL BRACKET 74MM S-STEEL
16	52.001.XXX	4MM KEDER SPLINE
17	52.002.000	25MM HBOX FELT
18	52.003.XXX	2" LONG NEODYMIUM MAGNET
19	52.005.000	60MM OCTAGONAL TUBE (X2 PER BLIND IF OVER 1072MM WIDE)
20	52.006.000	60MM OCTAGONAL TUBE IDLER END ASSEMBLY (15.5MM SQR SHAFT)
21	52.005.000	60MM OCTAGONAL TUBE IDLER END ASSEMBLY (HOUSING)
22		60MM OCTAGONAL TUBE IDLER END ASSEMBLY (BEARINGS)
23		60MM OCTAGONAL TUBE IDLER END ASSEMBLY (EXTERNAL CIRCLIPS)
24	52.006.000	60MM OCTAGONAL TUBE IDLER END ASSEMBLY (EXTERNAL CIRCLIPS)
25	52.007.063	16MM SQR IDLER END PLATE (R-CLIP)
26		16MM SQR IDLER END PLATE
27	52.007.063	16MM SQR IDLER END PLATE (SCREWS)
28	52.008.XXX	BOTTOM BAR
29	52.009.000	BOTTOM BAR PROBE (HOUSING BLOCK)
30	52.008.XXX	BOTTOM BAR PROBE (KEDER SCREWS)
31	52.009.000	BOTTOM BAR PROBE (SECURING SCREWS)
32	52.010.000	1" LONG NEODYMIUM MAGNET
33	52.001.030	BOTTOM RAIL WEIGHTS
34	52.012.000	BOTTOM BAR FELT
35	52.013.XXX	MAGNATRACK GUIDE
36	52.014.XXX	MAGNATRACK COVER
38	52.016.XXX	MAGNATRACK HOUSING
39	52.017.XXX	MAGNATRACK END CAP (MAIN BODY)
40	52.017.XXX	MAGNATRACK END CAP (SCREWS X8)
39	52.017.XXX	M150 HEADBOX END CAP (STD SCREWS X8)
41	52.018.XXX	MAGNATRACK BUMPER
42	52.020.XXX	M150 HEADBOX (BACK PLATE)
43	52.021.XXX	M150 HEADBOX COVER FRONT
44	52.022.XXX	M150 HBOX END CAP (REVEAL SCREW)
45	52.021.XXX	M150 HBOX END CAPS
46	52.027.000	4" DONUT (75MM LONG 4" TUBE)
47		4" DONUT (SECURING SCREWS)
48	52.029.XXX	MAGNATRACK FUNNEL (MAIN BODY)
49	52.029.XXX	MAGNATRACK FUNNEL (GRUB & SCREWS)
50	52.030.000	VELCRO

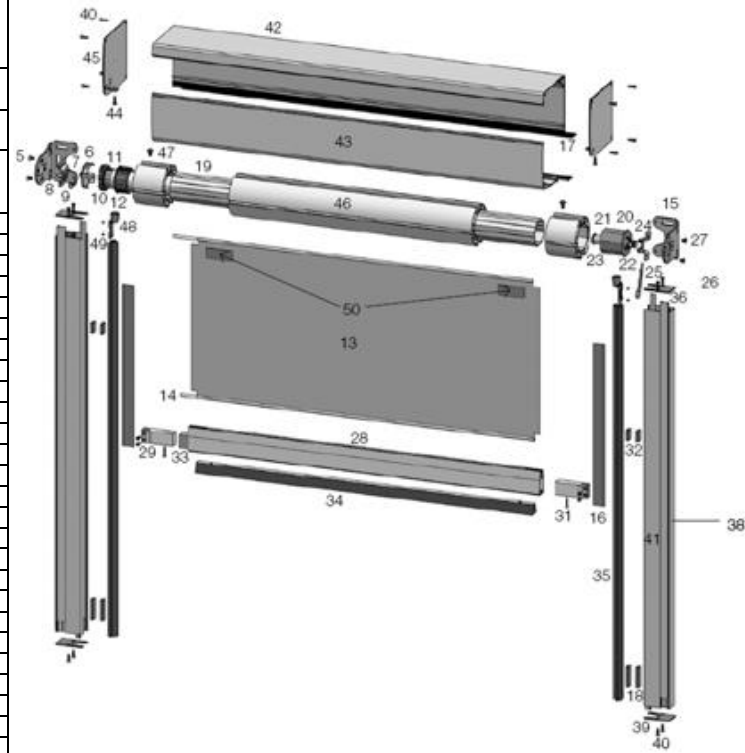

OPTIONS & LIMITATIONS

LIMITATIONS

LIMITATIONS	
MIN WIDTH	1000MM
MAX WIDTH	6500MM
MIN DROP	1000MM
MAX DROP	4000MM
MAX SQM	26SQM

DOUBLE BOTTOM BAR

The shaded area in pricelist grid will include a second bottom bar as standard for improved wind deployment.

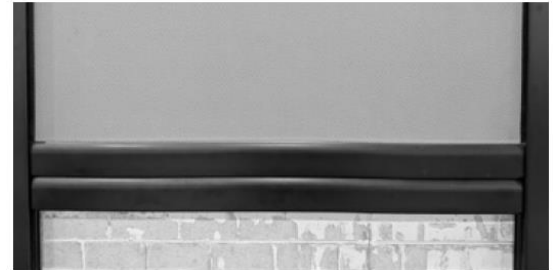

KEDER SELECTION

The Keder is welded to the fabric and connects the fabric to the MagnaTrack screen guide. Please select either white or black keder to coordinate with the MagnaTrack hardware or fabric.



AUTOMATION OPTIONS

Alpha MagnaTrack's are automated using Somfy Altus 50 RTS motor which is compatible with all Somfy RTS remote control options.

NOTE: MAGNATRACK AWNINGS ARE NOT AVAILABLE AS A CRANK CONTROL OPTION

MEASURING

OUTSIDE FIT WALL

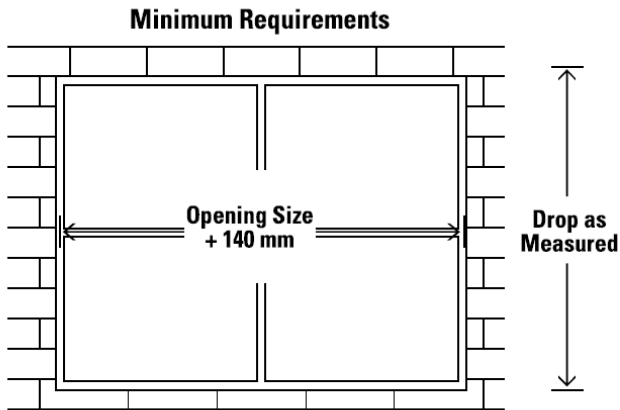

Outside Fit: Factory will make no deductions.
Deep Channel Dimensions: 81mm x 33.5mm
Side Tension Channel Dimensions: 73mm x 37.5mm

OUTSIDE FIT ARCHITRAVE

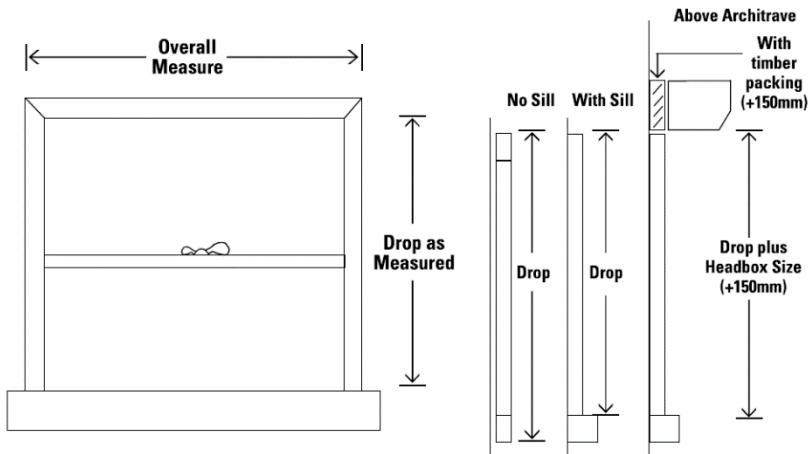

INSIDE FIT & TOP FIX (SIDE FIX)

Measure the top, the smallest opening and the bottom widths. Use the smallest opening size as the top width measurement.

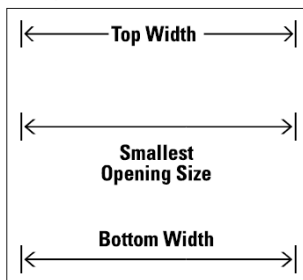

Factory will deduct 2mm.

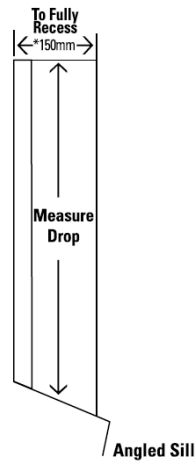
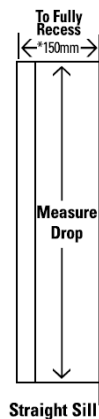

MEASURING INSTRUCTIONS

Accurate measuring of the Alpha MagnaTrack Awning is vital for successful fitting and consequential use. The product can be fitted on Face, Side or Ceiling fixing applications with motorised operation.

- Reveal fit - Headbox box and Tube Supplied Overall Size - 2mm
- Face fit - Supplied Overall Size
- ± 2 mm Manufacturing Tolerance

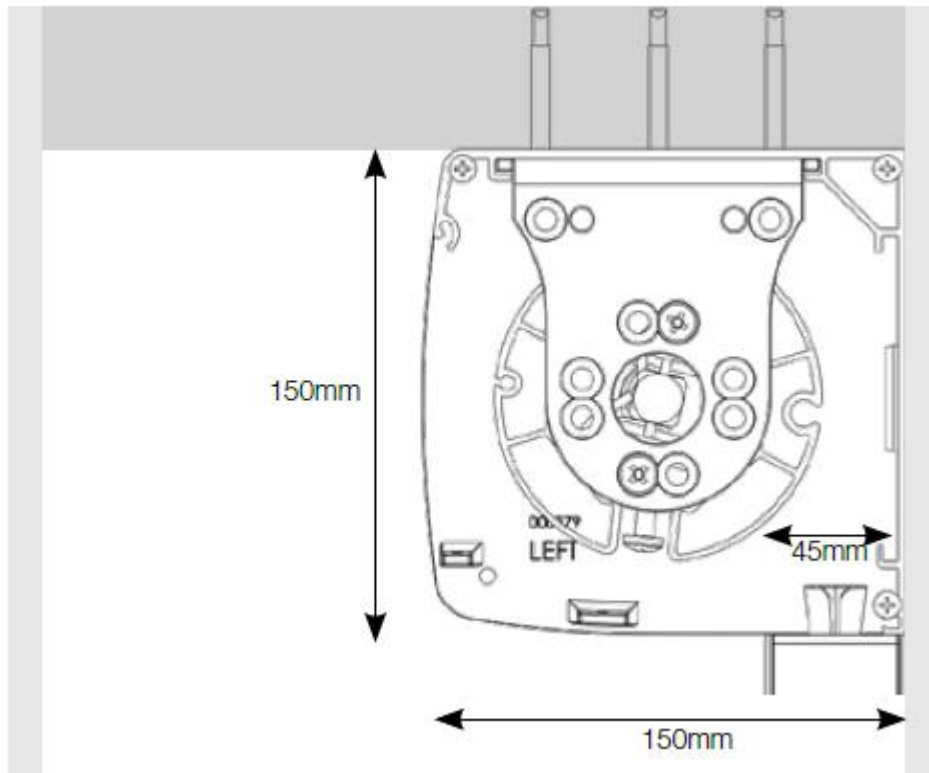

RECESS MEASURING

When installing a MagnaTrack awning into a recess situation, it is important that the awning is ordered **without** a headbox and recess is made at a minimum of 150mm high and 250mm wide.

Although the awning roll diameter will not exceed 150mm, the extra 100mm is to ensure the awning can be installed correctly.

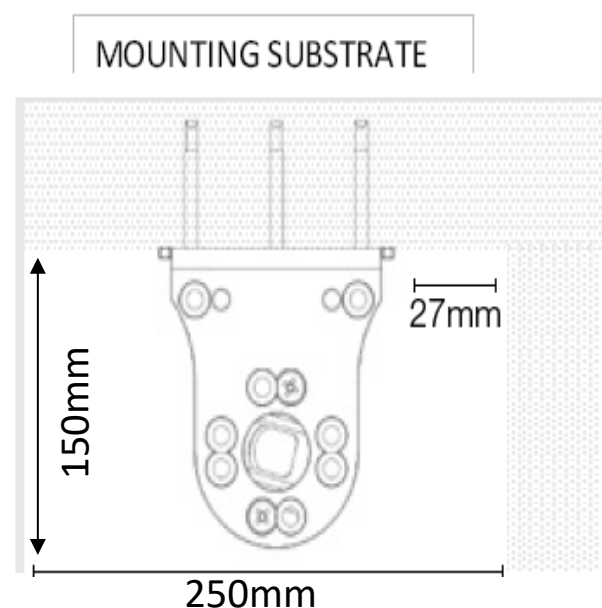

COMPONENT DIMENSIONS

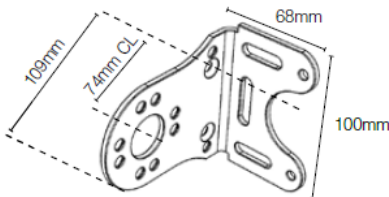

Alpha MagnaTrack 74mm
Universal Installation Bracket

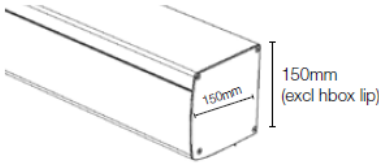

Alpha MagnaTrack Headbox

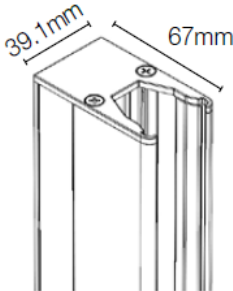

Alpha MagnaTrack Channels, Cover
and End Cap

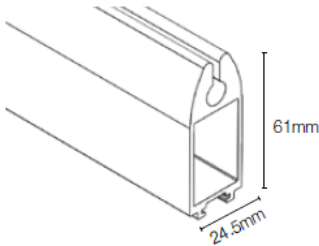

Alpha MagnaTrack Bottom Bar