

PowerView Manual

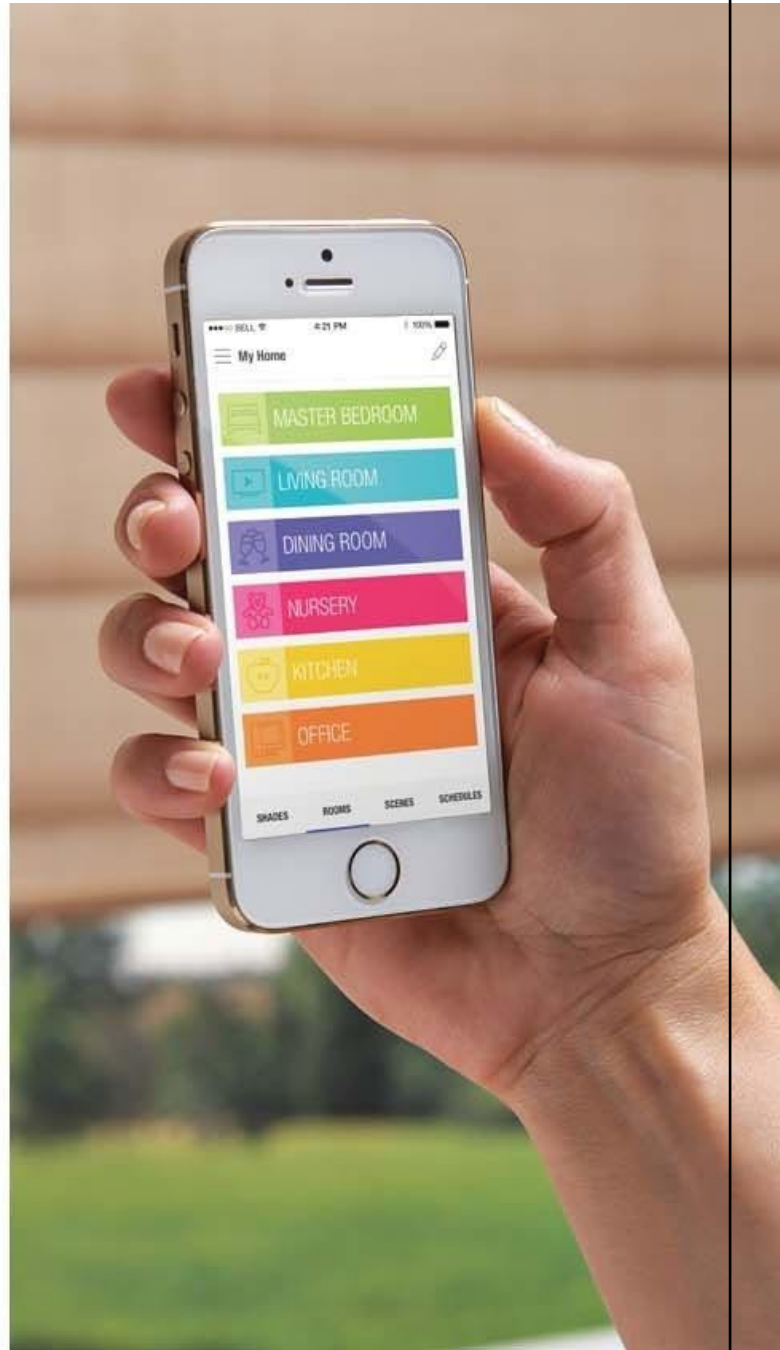



CONTENTS

POWerview PEBBLE REMOTE	5
Key to operation	6
Programming button configuration	
Programming mode	7
Pairing remotes	8
Duplicating a remote	9
Selecting & De-selecting groups	10
Joining a shade to a group	11
Removing a shade from a group	12
Setting a favourite	13
Product operation: Groups 1 – 6	14
Product operation: All button	15
Product operation: Favourite button	16
Product operation: Top Down/Bottom Up & Day/Night	17
Product operation: Silhouette	18
Product operation: Luminette	19
Product operation: PolySatin Shutters	20
Mounting PowerView surface	21
Battery replacement	22
Inserting the remote module into the pebble	23
POWerview REPEATERS	24
Pairing a repeater to a PowerView network using a remote	25
Pairing a repeater to a PowerView network using a Hub	26
Using repeaters with the PowerView app	27
Using repeaters in the PowerView app: Scenes	28
Using repeaters in the PowerView app: Automations	29
POWerview APP/HUB SETUP & OPERATION	30
Overview & System requirements	31
Getting started with the Hub	32
Initial app & Hub setup overview	33
Hub setup: Wired	34
Hub setup: Wireless	35
Secondary Hub setup: Wired	36
Secondary Hub setup: Wireless	37
Pairing a remote to a PowerView network using the Hub	38
PowerView account	39
Dashboard	40
Discover shades	41
Editing shade details	42
Creating & deleting rooms	43
Assigning shades to rooms	44
Shade operation	45
Creating, operating & deleting scenes	46
Creating, enabling, disabling & deleting automations	47
Automations: Sunrise/Sunset	48
Using RemoteConnect	49



CONTENTS

SCENE CONTROLLER	50
Adding a new Scene Controller	51
Adding & configuring scenes in a Scene Controller	52
Operating scenes with the Scene Controller	53
TROUBLESHOOTING	54
Performing a programming reset	55
Backing up the Hub	56
Emailing a Hub backup	
Restoring a Hub backup	
Frequently asked questions: General	57
Frequently asked questions: Networking	58
Frequently asked questions: PowerView Pebble Remote & Surface Remote	59
Frequently asked questions: PowerView App	60
Frequently asked questions: PowerView Hub	62
Frequently asked questions: PowerView Repeaters	63
Scenario 1	64
Scenario 2	65
Scenario 3	66
Scenario 4	68
Scenario 5	69
Scenario 6	



POWERSVIEW PEBBLE REMOTE



POWerview PEBBLE REMOTE

KEY TO OPERATION

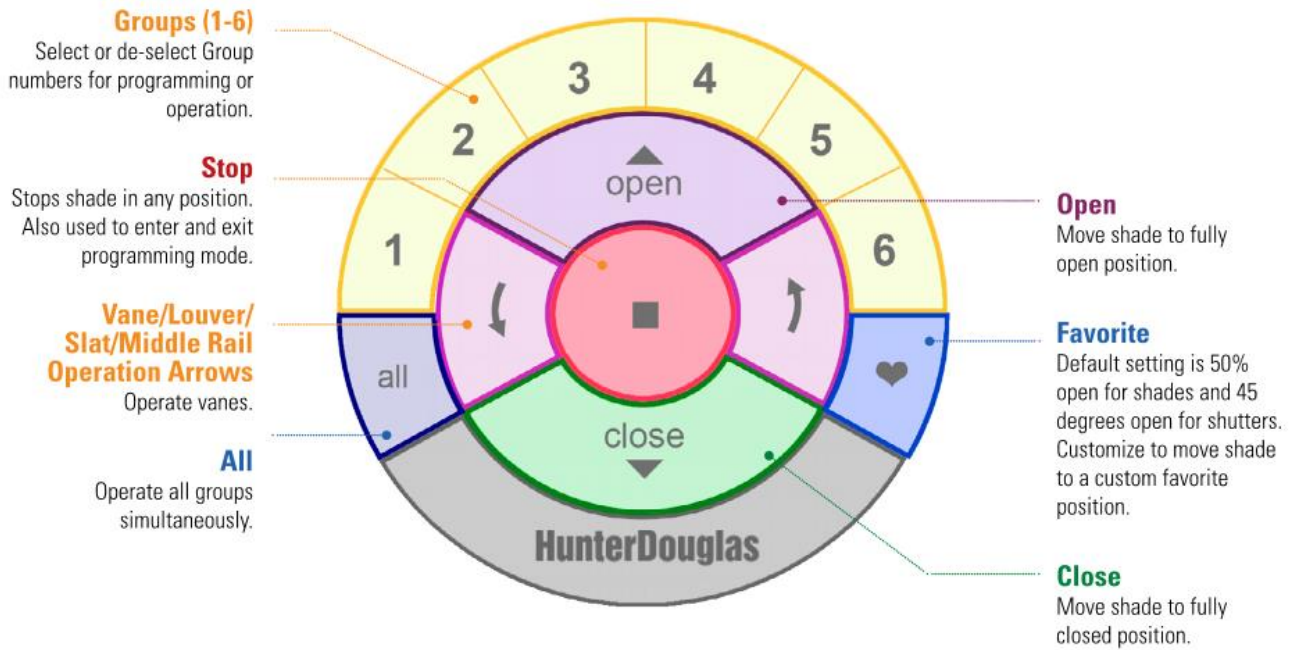

PROGRAMMING BUTTON CONFIGURATION

The location of the programming button can be different depending on the product.



POWerview PEBBLE REMOTE

PROGRAMING MODE

Programming Mode is required to perform key remote related programming procedures. In programming mode, you can set a variety of functions, from joining a shade to a Group number (1-6) on a remote to removing a shade from a Group number (1-6), to setting Favourite shade positions . You must activate programming mode on the PowerView Pebble Remote to establish communication between the remote and shade.

NOTE: Programming mode automatically times out at 20 seconds. Programming mode extends by an additional 20 seconds simply by pressing any button on the remote.

ENTER PROGRAMING MODE

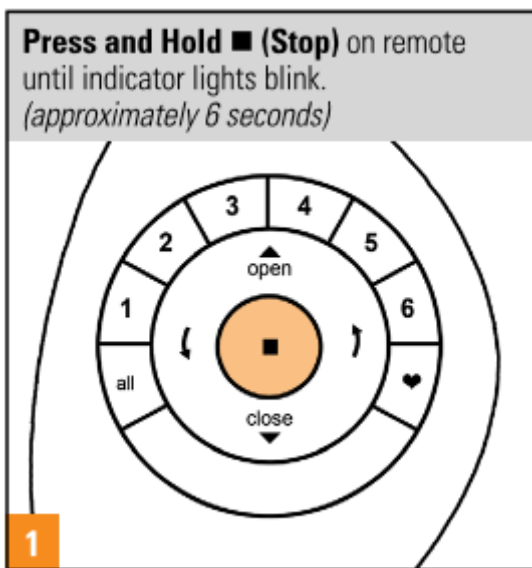

EXIT PROGRAMING MODE

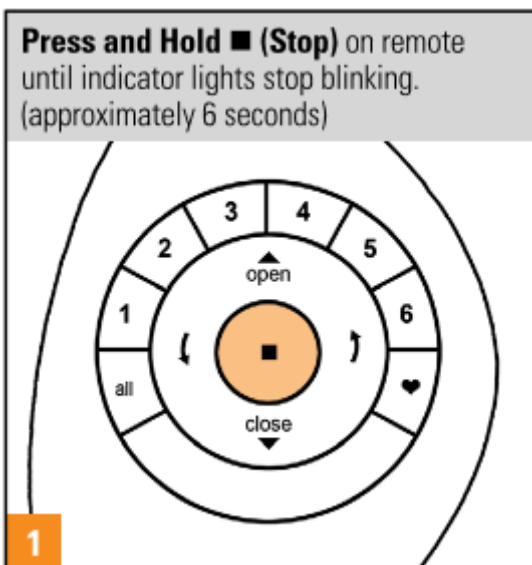

POWerview PEBBLE REMOTE

PAIRING REMOTES

Each PowerView Remote comes with its own unique Radio Frequency (Network) ID. If multiple remotes (i.e., PowerView Pebble and/or PowerView Surface remotes) will be used in the home, **PAIR ALL REMOTES BEFORE JOINING ANY WINDOW COVERING TO GROUP NUMBER(S) (1-6) ON ANY REMOTE.** This is done to ensure that if a PowerView Hub or PowerView Repeater(s) is to be used in the future, it can operate previously programmed window coverings in the home and be used in conjunction with all the remotes on a single, unified PowerView Shade Network. Otherwise, some window coverings will be unresponsive to commands sent from the Hub or Repeaters.

SELECT a source and a target(s) remote.

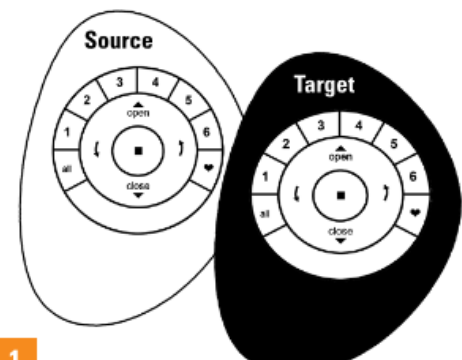

NOTE: If NO shades have been joined to a group number (1-6) on a remote, choose any remote to be the Source remote. Otherwise, choose the remote that was used to program/operate shade(s) to be the Source remote. A target remote receives information from the source remote.

1

Using a paper clip, **PRESS and HOLD recessed programming button** on back of target remote for **6-10 seconds**. If necessary, remove back cover.



NOTE: Group number (1-6) buttons will flash twice on the initial press of programming button, then again at six seconds. Target remote now ready to receive information from source remote.

2

On source remote, **PRESS and HOLD ■(Stop)** until indicator lights begin to blink. Source remote is now in Programming Mode.

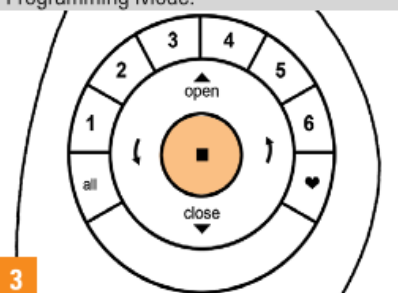

3

PRESS and CONTINUE TO HOLD ■(Stop) on target remote.

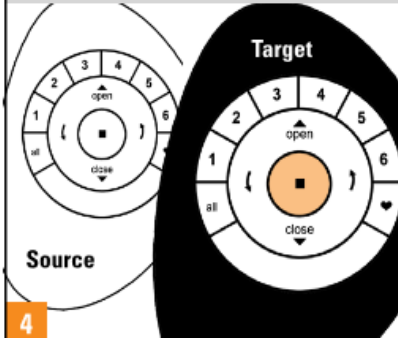

4

Simultaneously... **PRESS and RELEASE ■(Stop)** on source remote. **RELEASE (Stop)** on target remote.

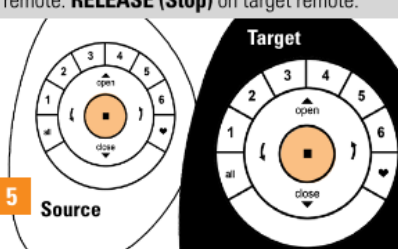

NOTE: Group numbers on target remote will flash twice to indicate it has been networked to the source remote.

5



POWerview PEBBLE REMOTE

DUPLICATING A REMOTE

Duplicating a remote copies a remote's unique Group programming information and transfers it to another remote so that they are essentially identical. Window coverings programmed to operate with one remote will also respond to commands from a duplicated remote. Duplicating a remote is not the same as pairing multiple remotes to a PowerView Shade Network.

SELECT the **source remote**. **SELECT** the **target remote**.

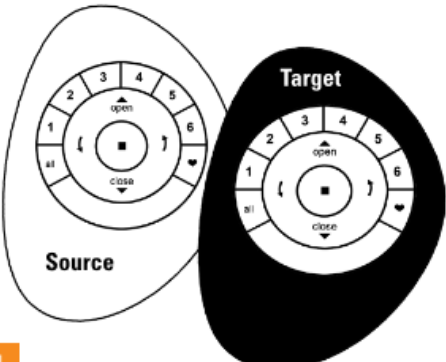

NOTE: The source remote is the remote to be duplicated. The target remote is the remote that receives the source remote's Group programming information.

1

Using a paper clip, **PRESS** and **HOLD** **recessed Programming button** on back of target remote for **6-10 seconds**. If necessary, remove back cover.



NOTE: Group number (1-6) buttons will flash twice on the initial press of Programming button, then again at six seconds. Target remote now ready to receive information from source remote.

2

On source remote, **PRESS** and **HOLD** **■(Stop)** until indicator lights begin to blink. Source remote is now in Programming Mode.

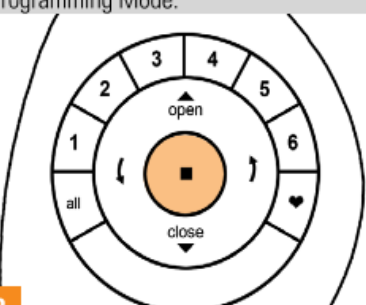

3

PRESS and **HOLD** **All** on target remote.

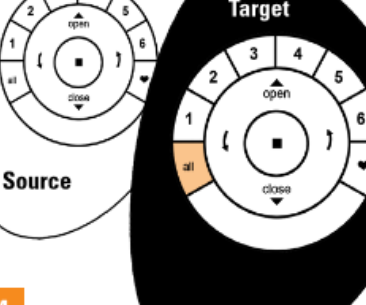

4

Simultaneously... **PRESS** and **RELEASE** **■(Stop)** on source remote. **RELEASE** **All** on target remote.

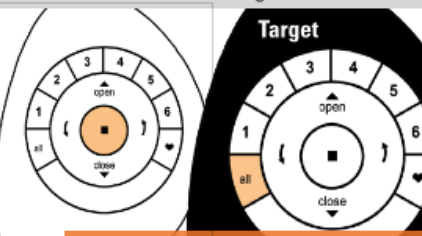

NOTE: The Group numbers (1-6) on the target remote will flash twice. This indicates that the source remote's Group programming information has been duplicated and transferred to the target remote. Both remotes are now identical.

5



POWerview PEBBLE REMOTE

SELECTING & DE-SELECTING GROUPS

Before operating a single window covering you must first select its corresponding Group number (1-6) or the ALL button. Multiple Group numbers can be selected for simultaneous operation in any combination. Group numbers can be selected or deselected. Like any Group number, the ALL button can also be selected or deselected; however, its selection will override any active Group(s).

SELECTING A GROUP

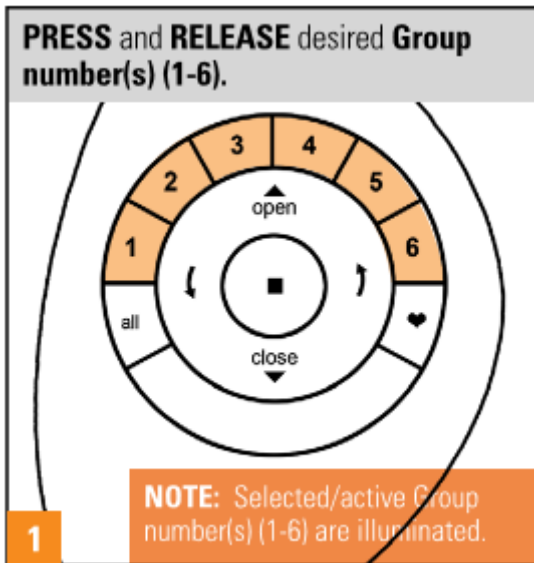

DE-SELECTING A GROUP

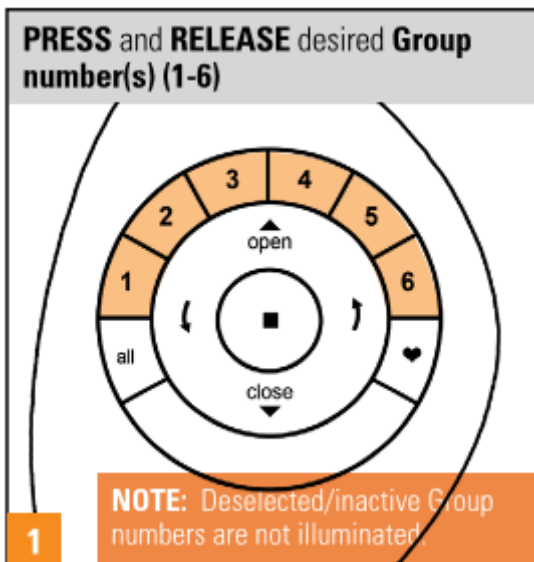

POWerview PEBBLE REMOTE

JOINING A SHADE TO A GROUP

To operate shades using a remote, shades must be joined to a Group number (1-6) on the remote. A single shade can be joined to multiple Groups on a remote, if desired.

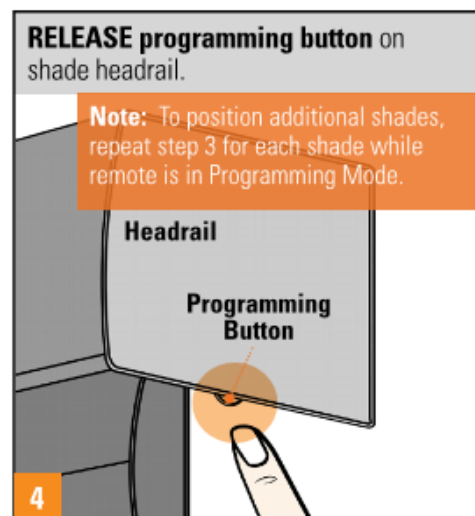
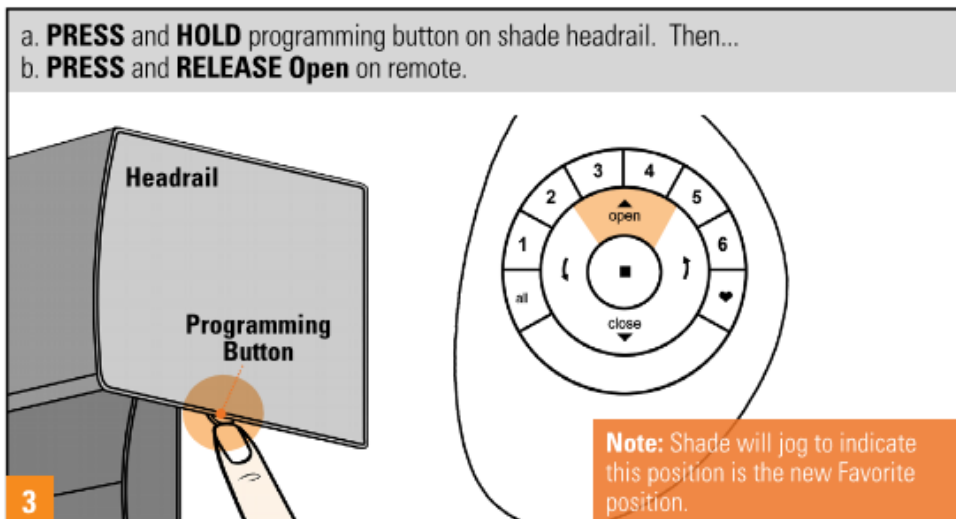
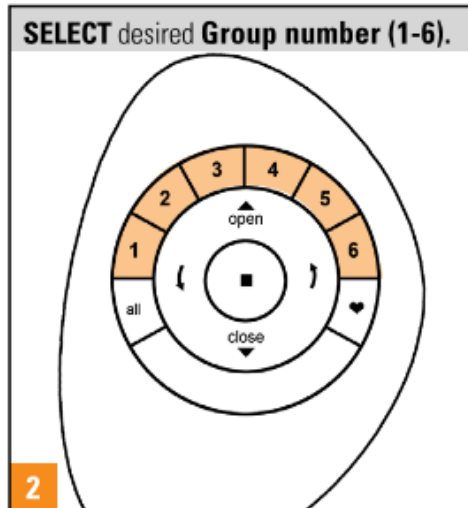
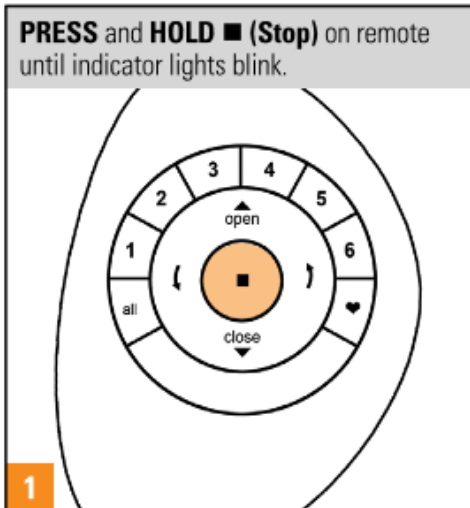

POWerview PEBBLE REMOTE

REMOVING A SHADE FROM A GROUP

1 **PRESS** and **HOLD** **■ (Stop)** on remote until indicator lights blink.

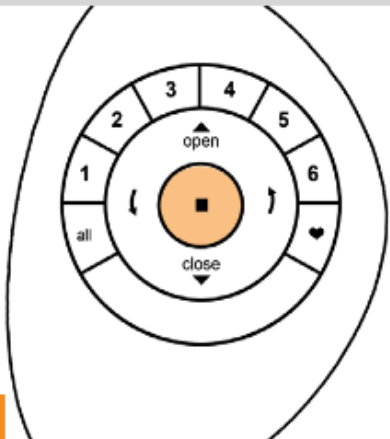

2 **PRESS** and **RELEASE** desired **Group number (1-6)**.

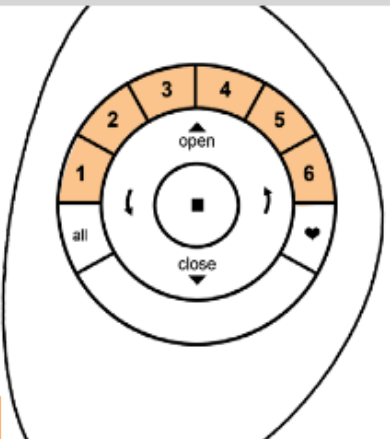

a. **PRESS** and **HOLD** **programming button** on shade headrail. Then...
b. **PRESS** and **RELEASE** **Close** on remote.

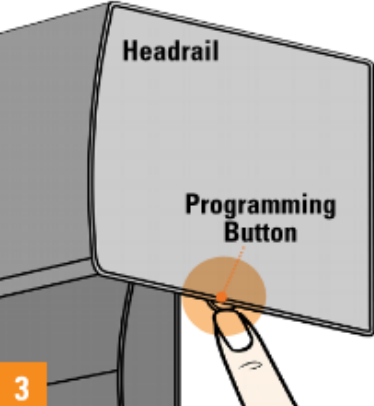

3

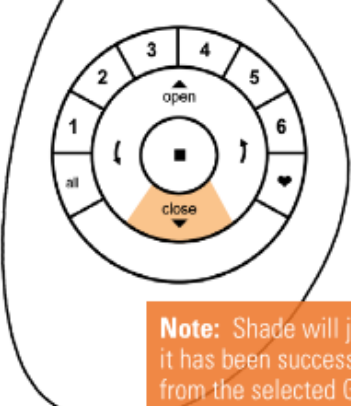

Note: Shade will jog to indicate it has been successfully removed from the selected Group.

RELEASE programming button on shade headrail.

Note: To remove additional shades from the same Group, repeat step 3 for each shade while remote is in Programming Mode.

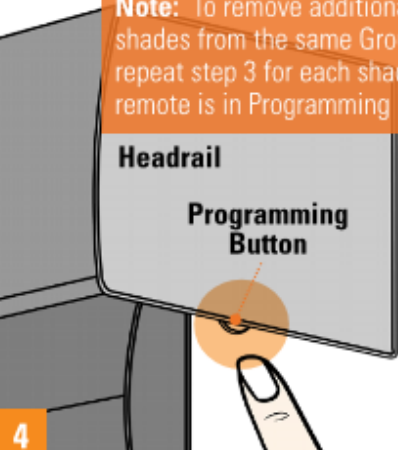

4



POWerview PEBBLE REMOTE

SETTING A FAVOURITE

All shades come from the factory with a default Favourite position set at 50% open, or louvers 45 degrees open for shutters. If you prefer a different shade position, you can create a custom Favourite.

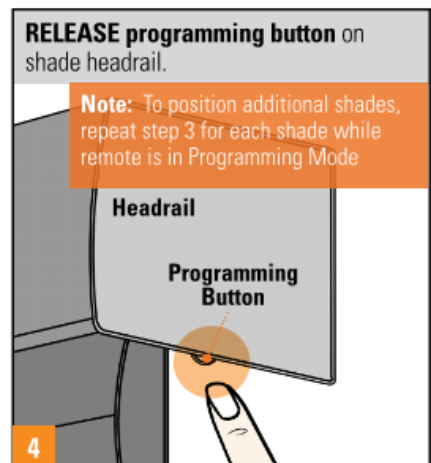
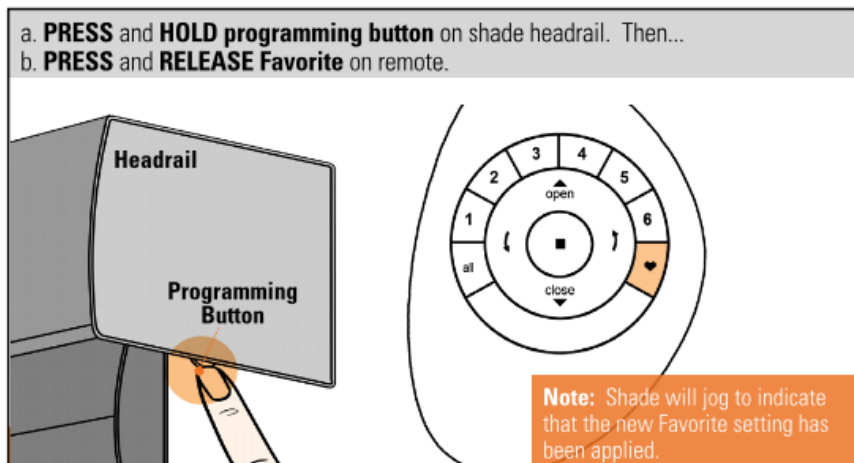
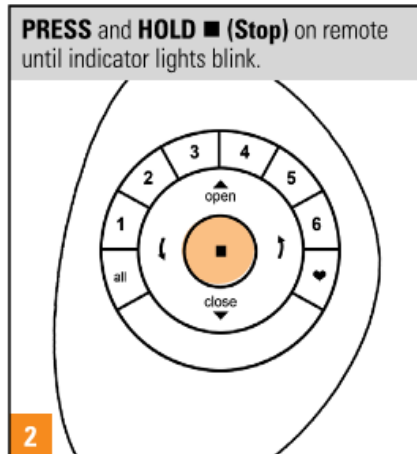
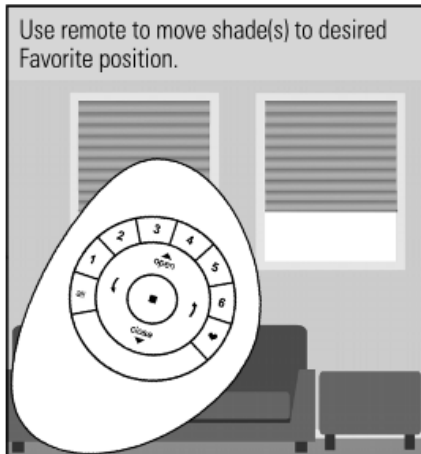

POWerview PEBBLE REMOTE

PRODUCT OPERATION: GROUPS 1 - 6

PRESS and RELEASE desired **Group number (1-6)**.

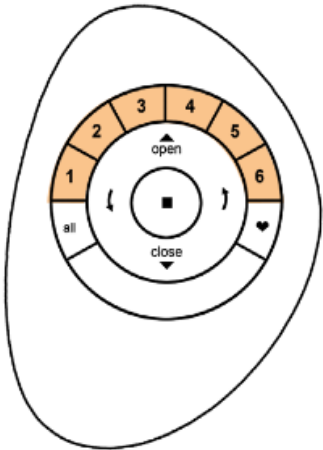

NOTE: Group numbers (1-6) are selected or deselected by pressing the desired Group number(s). Selected Group numbers are illuminated to indicate they are active. Multiple Groups can be selected for simultaneous operation.

1

PRESS and RELEASE either:

- A. Open** on the remote to open shade
- B. Close** on the remote to close shade
- C. Right Arrow** for vane, middle rail, louver or slat
- D. Left Arrow** for vane, middle rail, louver or slat

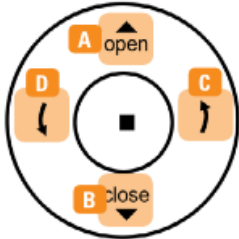

2

PRESS and RELEASE ■ (**Stop**) when the desired shade position is reached.

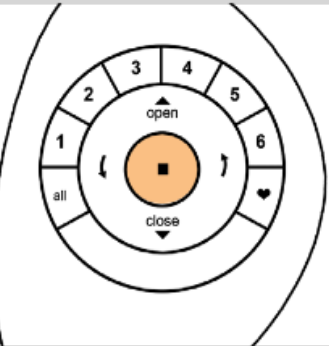

3



POWerview PEBBLE REMOTE

PRODUCT OPERATION: ALL BUTTON

The ALL button allows all Grouped shades to be operated simultaneously.

PRESS and RELEASE All button.

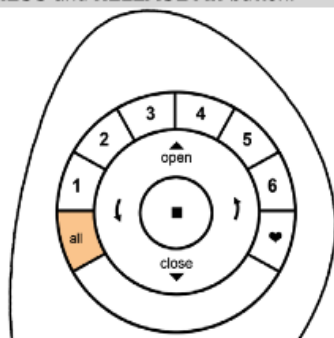

1

NOTE: To de-select ALL, press any Group number.

PRESS and RELEASE either:

- A. Open** on the remote to open shade
- B. Close** on the remote to close shade
- C. Right Arrow** for vane, middle rail, louver or slat operation
- D. Left Arrow** for vane, middle rail, louver or slat operation

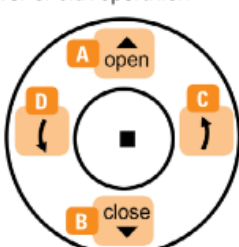

2

PRESS and RELEASE ■ (Stop) when the desired shade position is reached.

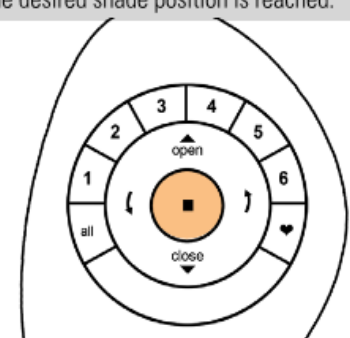

3



POWerview PEBBLE REMOTE

PRODUCT OPERATION: FAVOURITE BUTTON

The Favourite button moves selected Grouped shades to their individually set Favourite positions . All shades come from the factory with a default Favourite position set at 50% open, or louvers 45 degrees open for shutters . If you prefer a different shade position, you can create a custom Favourite.

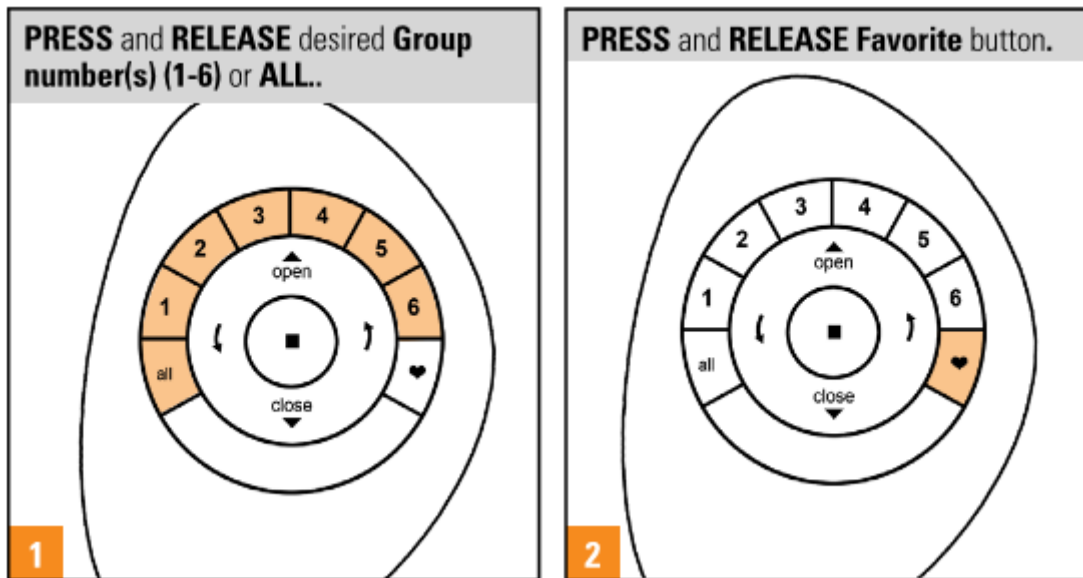

POWerview PEBBLE REMOTE

PRODUCT OPERATION: TOP DOWN/BOTTOM UP & DAY/NIGHT

The PowerView Pebble Remote does not allow for both the middle and top rails to each have a midpoint within the window at the same time.

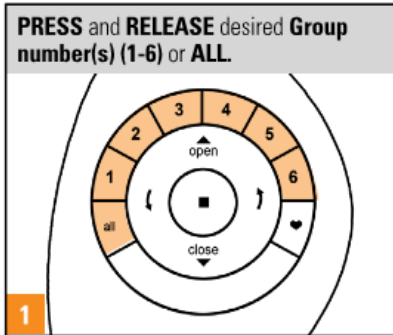

PRESS and RELEASE either:

With Shade in Fully Closed Position

- A. **Open** to raise bottom rail
- B. **Left Arrow** to lower middle rail

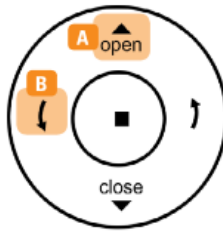

With Middle Rail Fully Lowered

- A. **Open** to fully raise middle rail, then fully raise bottom rail
- B. **Right Arrow** to raise middle rail
- C. **Close** to fully raise middle rail

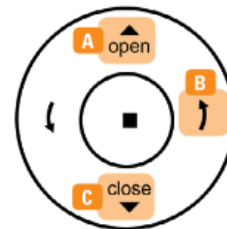

With the Middle Rail in an Intermediate Position

- A. **Open** to fully raise middle rail, then raise bottom rail
- B. **Left Arrow** to lower middle rail
- C. **Right Arrow** to raise middle rail
- D. **Close** to fully raise middle rail

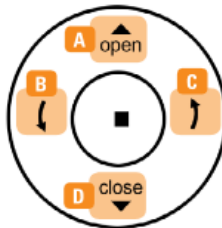

With Bottom Rail in Partially or Fully Raised Position

- A. **OPEN** to raise bottom rail
- B. **LEFT ARROW** to lower bottom rail, then middle rail
- C. **RIGHT ARROW** to lower bottom rail
- D. **CLOSE** to lower bottom rail

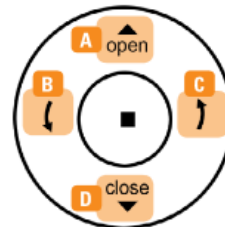

2

PRESS and RELEASE ■ (Stop) when the desired shade position is reached.

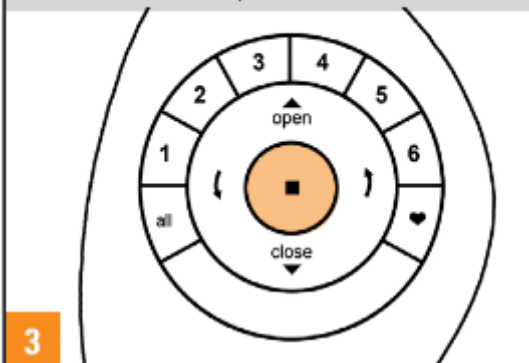

POWerview PEBBLE REMOTE

PRODUCT OPERATION: SILHOUETTE

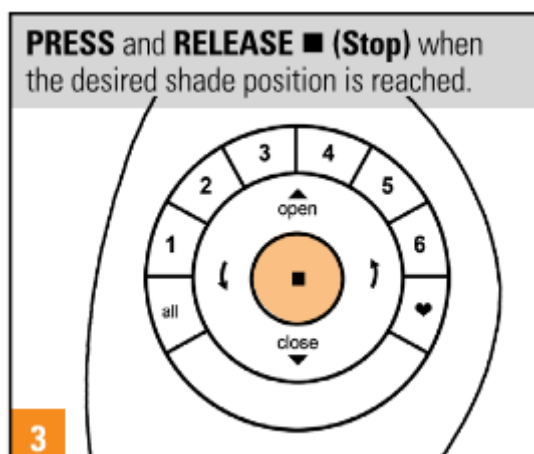
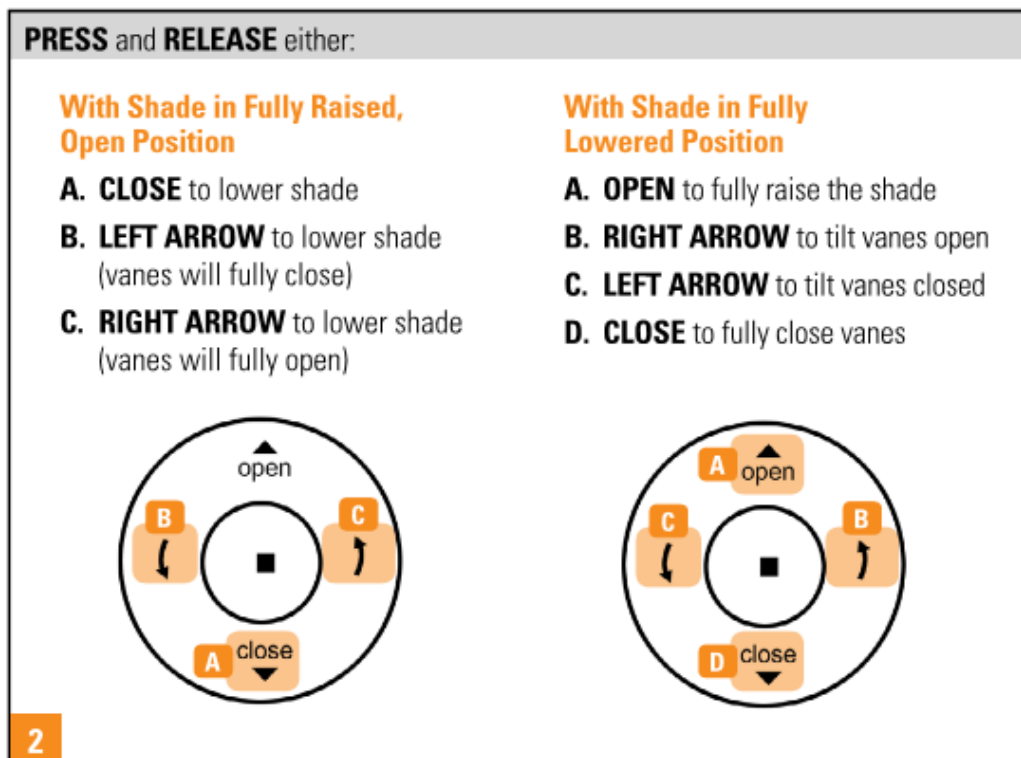
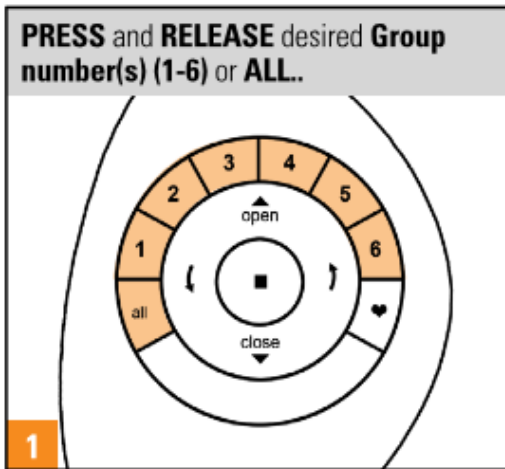

POWerview PEBBLE REMOTE

PRODUCT OPERATION: LUMINETTE

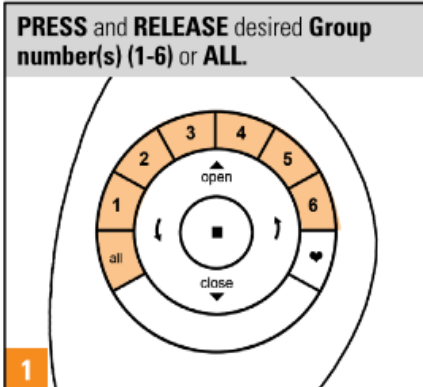

PRESS and RELEASE either:

With Shade in Fully Open Position

- A. CLOSE** to fully traverse the shade to the closed, vanes open position
- B. LEFT ARROW** to fully traverse the shade closed (vanes then rotate left to fully closed position)
- C. RIGHT ARROW** to fully traverse the shade closed (vanes then rotate right to fully closed position)

With Shade in Fully Closed Position

- A. OPEN** to traverse the shade to the open position
- B. LEFT ARROW** to rotate vanes to the left
- C. RIGHT ARROW** to rotate vanes to the right

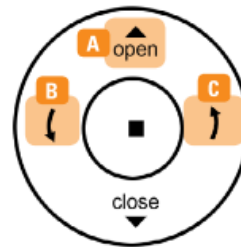
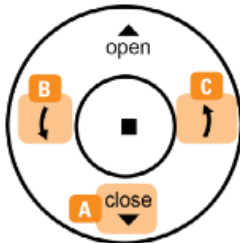

PRESS and RELEASE ■ (Stop) when the desired shade position is reached.

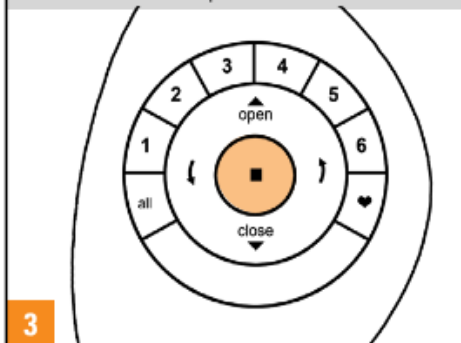

POWerview PEBBLE REMOTE

PRODUCT OPERATION: POLYSATIN SHUTTERS

MANUAL OPERATION

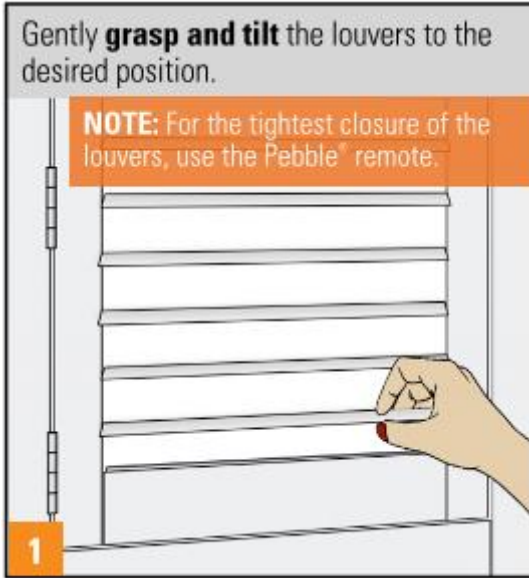

REMOTE OPERATION

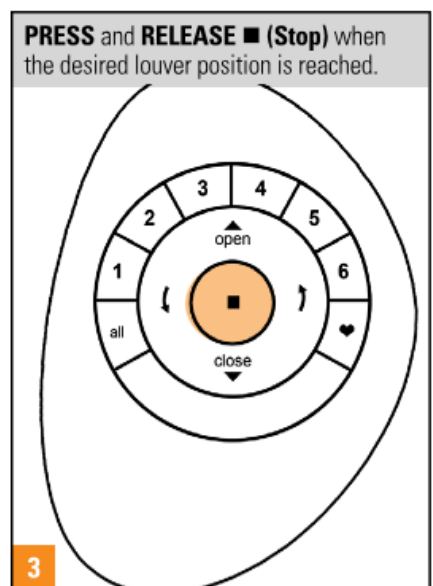
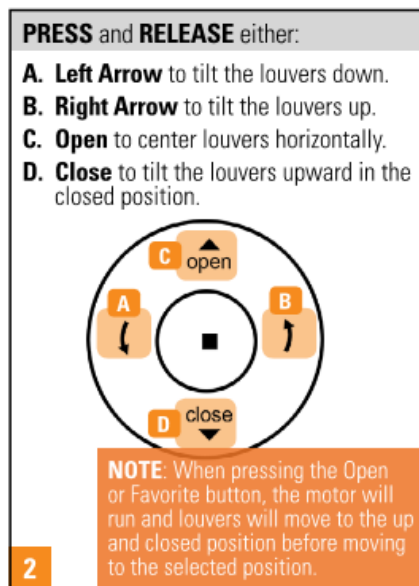
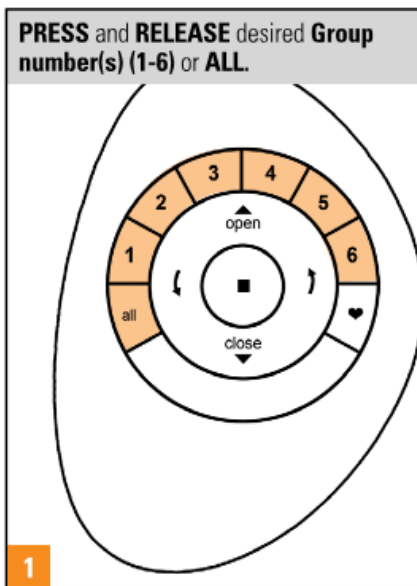

POWerview PEBBLE REMOTE

MOUNTING THE POWerview SURFACE

SELECT a location to mount the PowerView® Surface.



1

With a pencil, **LIGHTLY MARK** the location for the PowerView® Surface on the mounting surface

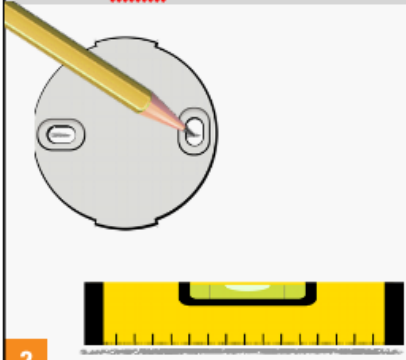

Option A.
Use the screw holes on the Surface mounting plate to mark the location. The Hunter Douglas logo should appear right side up and be horizontal.

Option B.
To ensure a straight and level appearance, use a small, standard bubble level with a ruled edge. Mark a straight horizontal line approximately 1-3/4" in length on the mounting surface.

2

PLACE the Surface mounting plate on the mounting surface, lining up the screw holes on the mark.

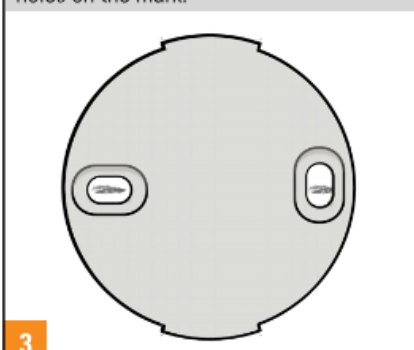

3

ATTACH the Surface mounting plate to the mounting surface using the screws provided.

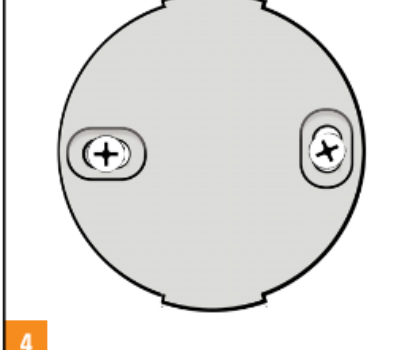

Option A.
If you are mounting the Surface onto drywall, use a 7/32" drill bit to drill pilot holes. Tap drywall anchors into the pilot holes until the flange of the anchor is flush with the drywall.

Option B.
If you are mounting the Surface onto wood, use a 3/32" drill bit to drill the screw holes.

4

LINE UP the cut-outs on the Surface ring with the notches on the mounting plate.

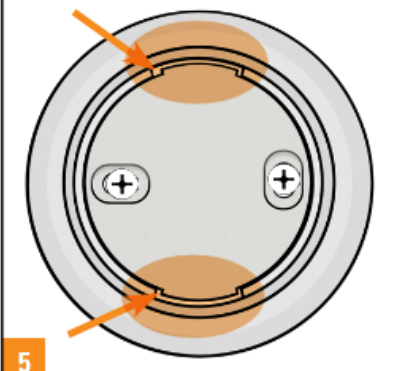

5

INSERT the Surface ring around mounting plate, **ROTATING** to the right to securely lock into place.

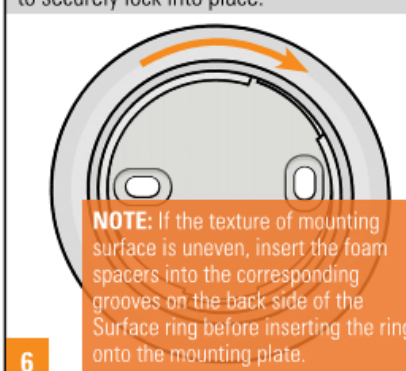

NOTE: If the texture of mounting surface is uneven, insert the foam spacers into the corresponding grooves on the back side of the Surface ring before inserting the ring onto the mounting plate.

6

Gently **INSERT** the Surface remote into the Surface ring until it is snug, **LINING UP** the raised notches of the Surface remote with the indentations in the Surface ring.

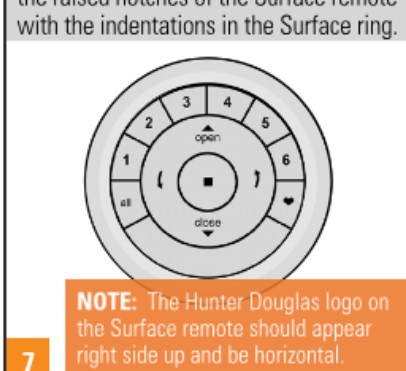

NOTE: The Hunter Douglas logo on the Surface remote should appear right side up and be horizontal.

7



POWerview PEBBLE REMOTE

BATTERY REPLACEMENT

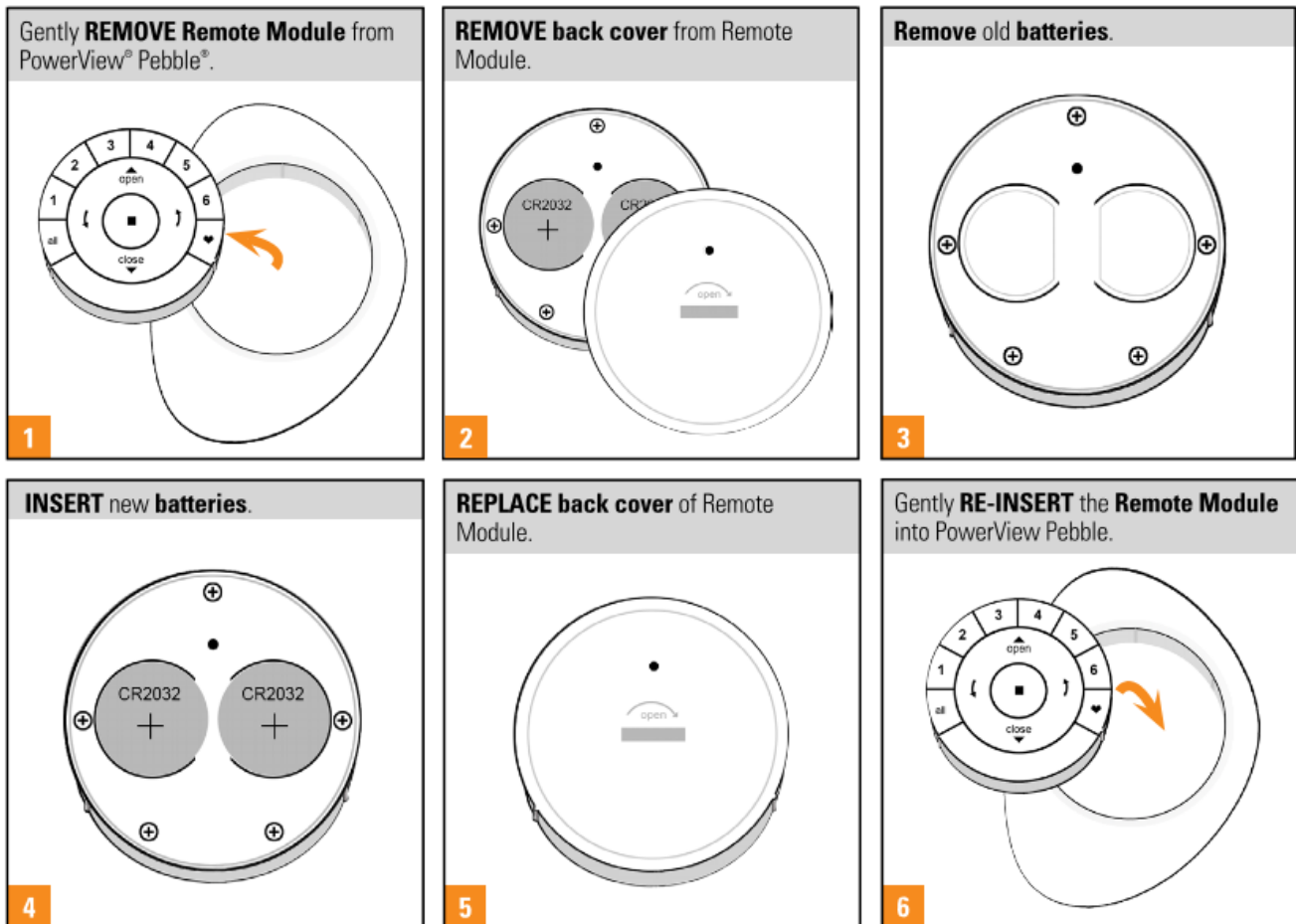

POWerview PEBBLE REMOTE

INSERTING THE REMOTE MODULE INTO THE PEBBLE

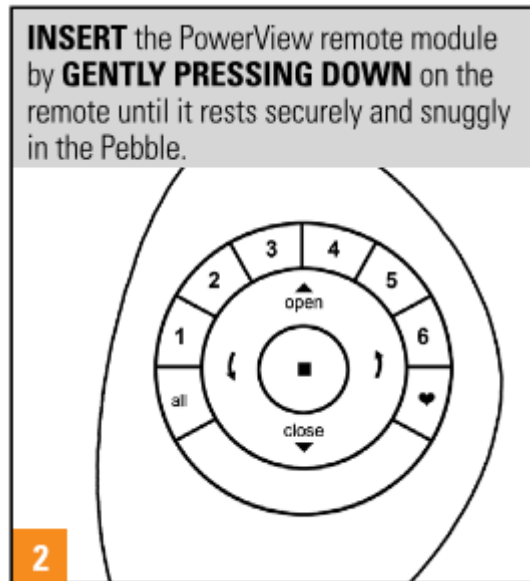
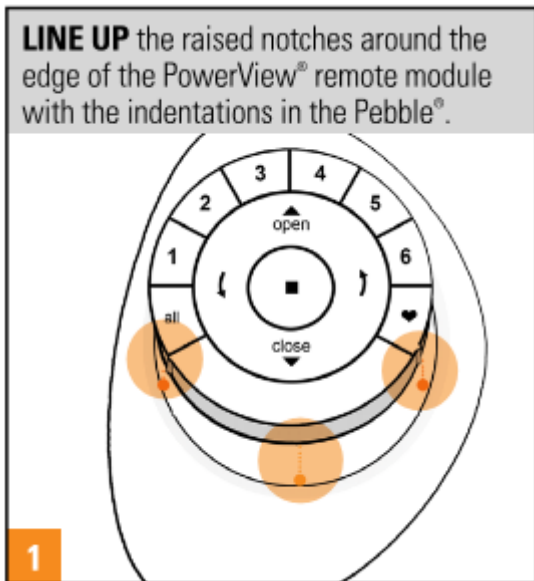

POWERSVIEW REPEATERS



POWerview REPEATERS

PAIRING A REPEATER TO A POWerview NETWORK USING A REMOTE

Repeaters extend the range of the PowerView Shade Network. Use Repeaters to ensure commands sent from the PowerView Pebble Remote, the PowerView Surface, or the PowerView Hub reach PowerView window coverings in large rooms or multiple room applications.

NOTE: A Generation 1 (Gen 1) Repeater Kit comes packed with a USB power source.

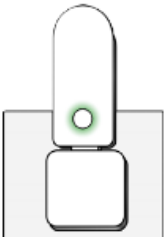
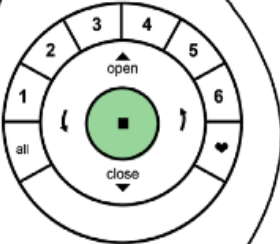
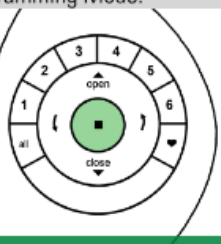
<p>ASSEMBLE Repeater Kit. PLUG the Repeater into an electrical outlet.</p>  <p>NOTE: A solid green light will illuminate on the Repeater to indicate that it is receiving power and ready to join a network.</p> <p>1</p>	<p>PRESS and HOLD ■ (Stop) on the PowerView Pebble Remote until indicator lights on the interior of the remote blink.</p>  <p>NOTE: This puts the remote in Programming Mode.</p> <p>2</p>	<p>HOLD the remote in close proximity to the Repeater.</p> <p>PRESS ■ (Stop) on the remote while the remote is in Programming Mode.</p>  <p>NOTE: The solid green light on the Repeater will go out, indicating it has been paired to the remote.</p> <p>3</p>
--	---	---



POWerview REPEATERS

PAIRING A REPEATER TO A POWerview NETWORK USING A HUB

Ideally, Repeaters would be joined to a Hub network at the time of installation and Hub setup using the Discover function in the PowerView App. However, additional Repeaters can be added to a PowerView Shade Network later using the Hub, if necessary.

NOTE: A Generation 1 (Gen 1) Repeater Kit comes packed with a USB power source.

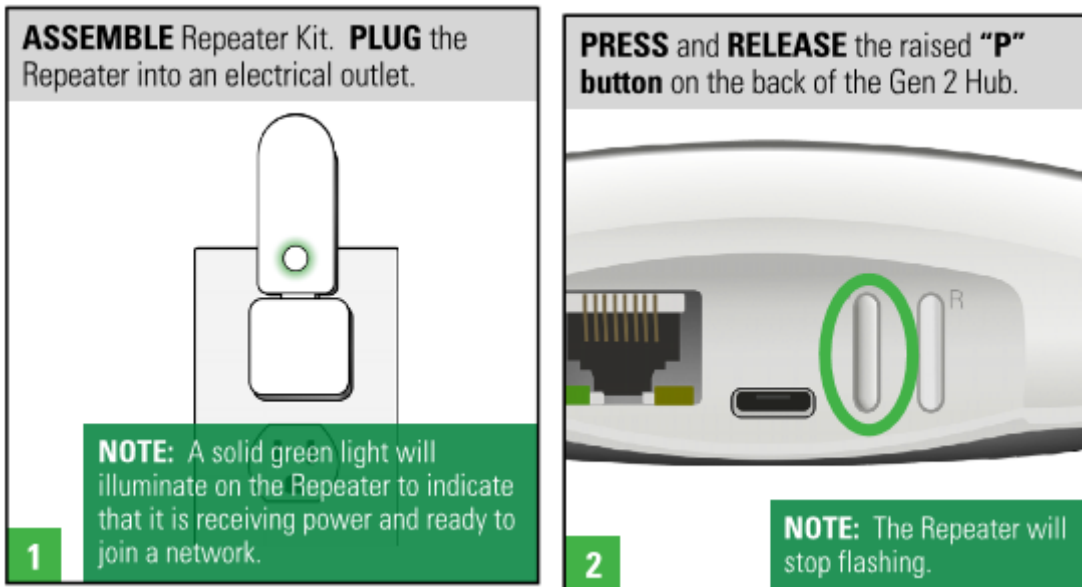

POWerview REPEATERS

USING REPEATERS WITH THE POWerview APP

REPEATERS IN ACCESSORIES

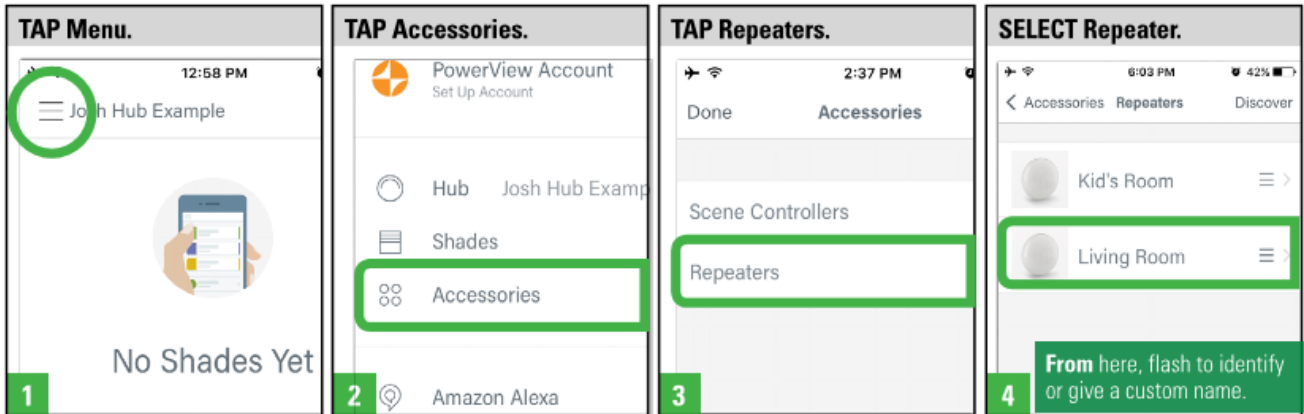

CHANGE REPEATER COLOURS OR ADJUST BRIGHTNESS

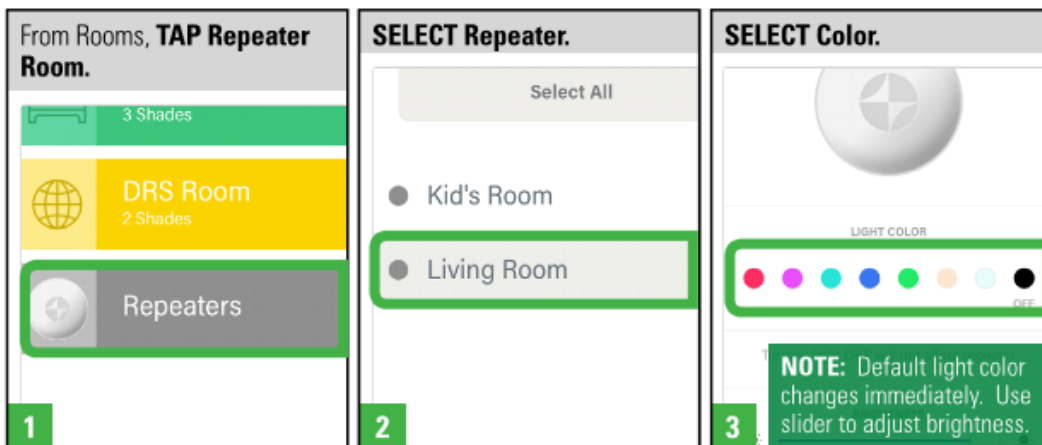

POWerview REPEATERS

USING REPEATERS IN THE POWerview APP: SCENES

Create a Repeater(s) Scene(s) to change the light colour of Gen 2 Repeaters. Then, customize shade operation by using a Repeater Scene in a Multi-Room Scene to change a Repeater's light colour when that Multi-Room Scene is activated.

Note: A Repeater Scene by itself will only change the light colour of a Gen 2 Repeater. It will not operate the shade. To coordinate a Repeater light colour change with shade operation, include a Repeater Scene in a Multi-Room Scene.

CREATE A REPEATER SCENE

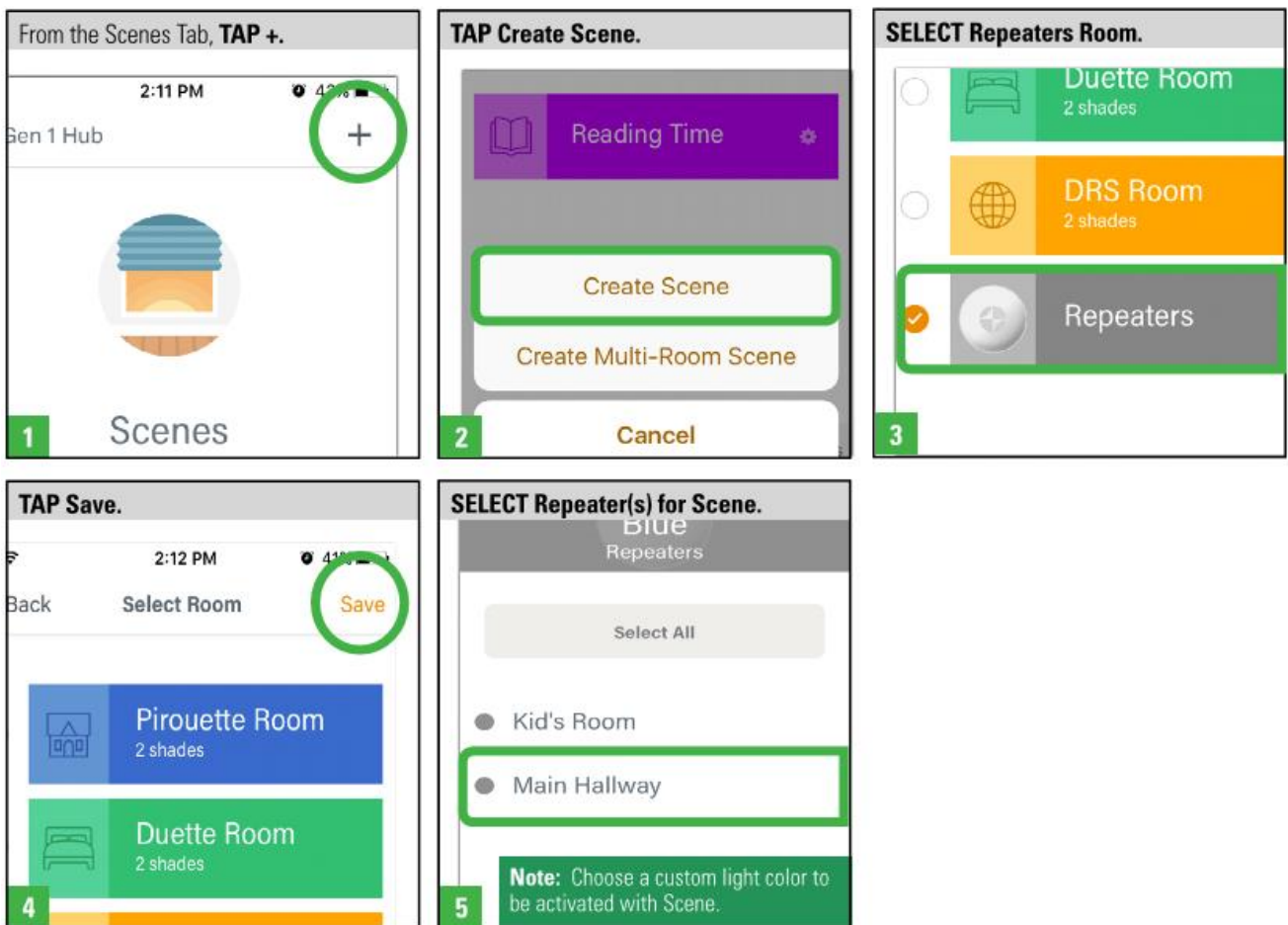

POWerview REPEATERS

USING REPEATERS IN THE POWerview APP: AUTOMATIONS

CREATE AUTOMATION

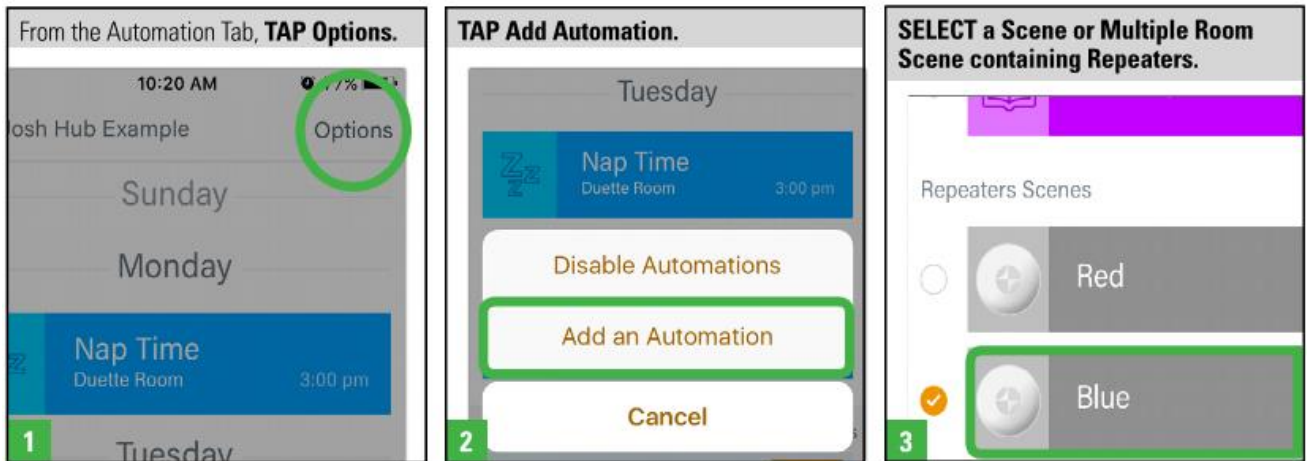

POWERSHIFT APP/HUB SETUP & OPERATION

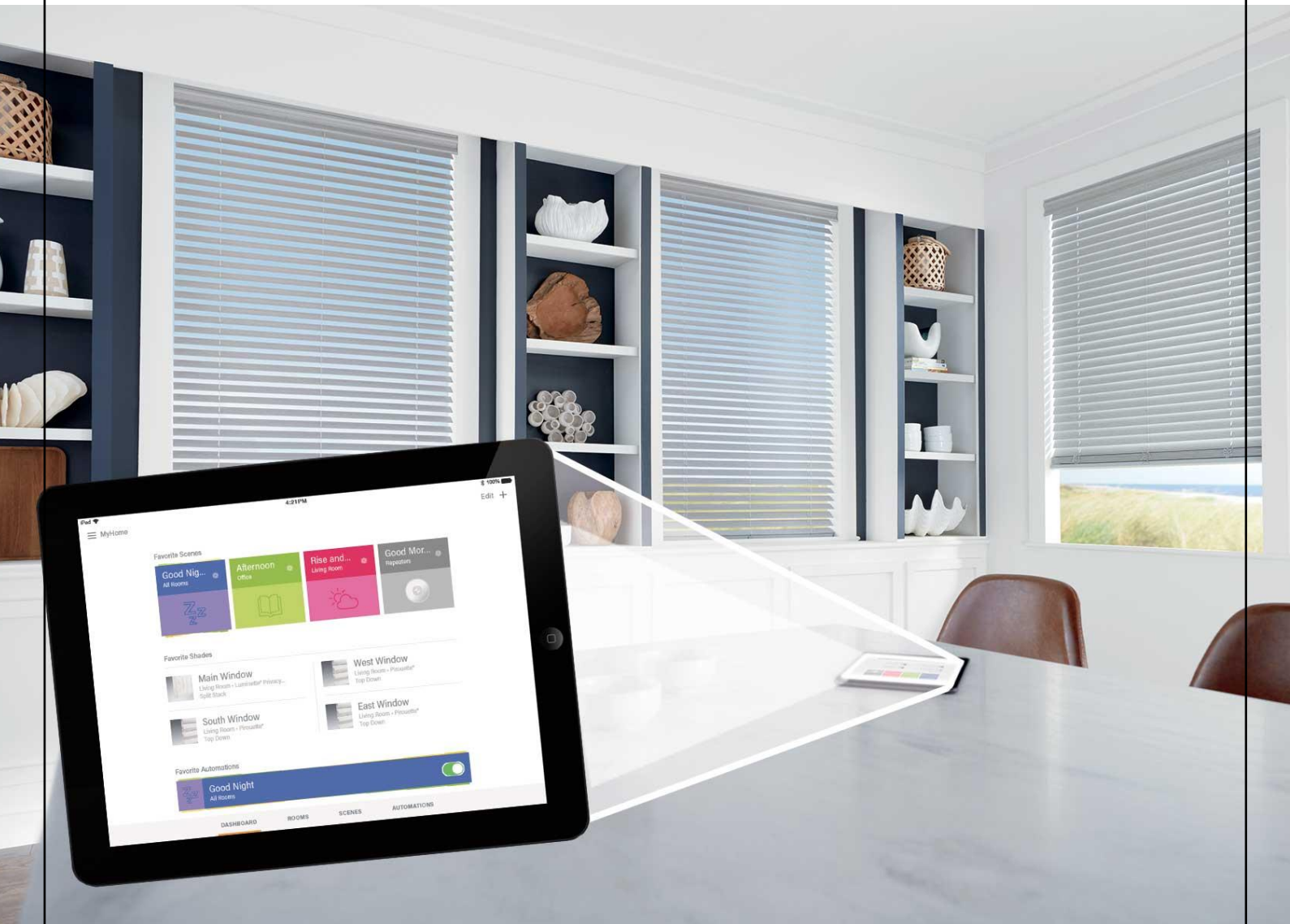

POWERSHIFT APP/HUB SETUP & OPERATION

OVERVIEW & SYSTEM REQUIREMENTS

SYSTEM REQUIREMENTS FOR THE POWERSHIFT APP

The PowerShift App allows for customized control and operation of PowerShift window coverings from Apple iOS and Android tablet or mobile devices. For households wishing to use the PowerShift App to operate shades, as well as utilize the many advanced whole home integration features available through PowerShift, the PowerShift Hub is required. PowerShift features compatibility with a variety of 3rd party control systems and devices through cloud-to-cloud and IP integration. Advanced features such as integration with Apple HomeKit, voice activation of shades via Amazon Alexa products or with Siri on iOS devices, the Generation 2 (Gen 2) Hub is required.

SYSTEM REQUIREMENTS FOR THE POWERSHIFT APP

To finalize the installation of all PowerShift window coverings in the home for customers wishing to use the PowerShift App, it will be necessary to establish a PowerShift network using the Hub.

POWERSHIFT MINIMUM REQUIREMENTS

- Mobile device (iPad, iPod touch or iPhone with iOS 10 .0 or higher installed)
- Android device running version 4 .4 (Kit Kat or newer)
- PowerShift Hub Kit
- PowerShift Hub
- Ethernet Cable
- USB Power Supply and Power Supply Cable
- Home Internet service

DOWNLOAD AND INSTALL THE POWERSHIFT APP

Download the PowerShift App for iOS devices from the App Store or for Android devices from Google Play.



POWerview APP/HUB SETUP & OPERATION

GETTING STARTED WITH THE HUB



BACK OF HUB

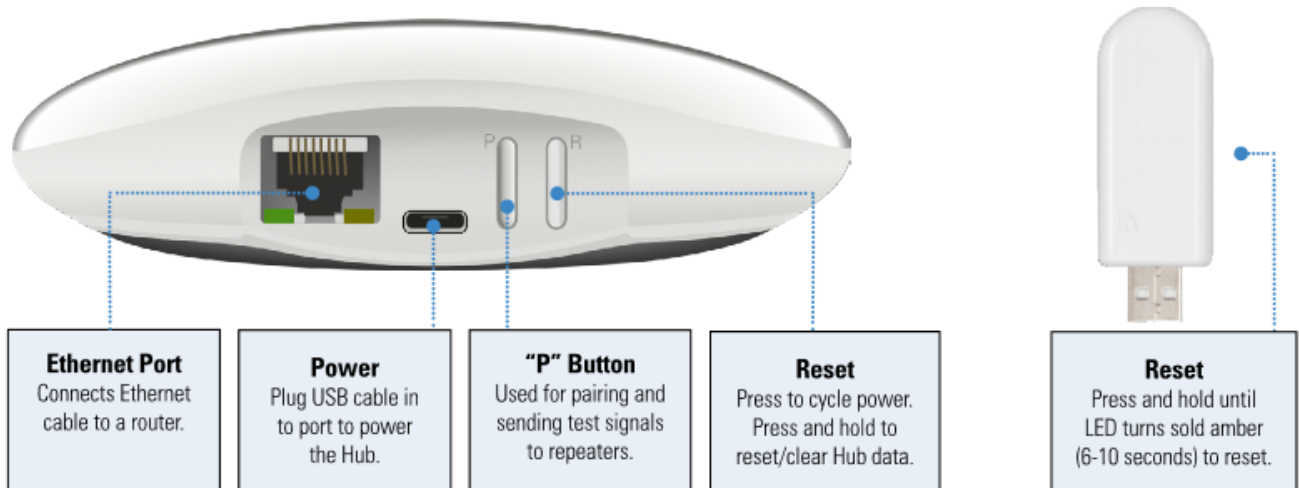

POWerview APP/HUB SETUP & OPERATION

INITIAL APP & HUB SETUP OVERVIEW

A PowerView Hub is required to use the PowerView App. To connect to and/or setup a Hub for operation of PowerView window coverings using the App, open the PowerView App on your mobile device and follow the on-screen instructions. For new Hub setup, you will be guided through the setup process. This may include Hub wireless configuration (if necessary), pairing any PowerView remotes to a single PowerView network (if necessary), and pairing any PowerView remotes to the Hub (if necessary).

Note: Always connect a Hub to power before beginning the setup procedure.



POWERSVIEW APP/HUB SETUP & OPERATION

HUB SETUP: WIRED

Connecting a PowerView Hub via ethernet to an internet connected router is the most reliable method to ensure uninterrupted internet access during Hub setup and operation.

PRIOR TO INSTALLATION
CONNECT Hub to: A) Ethernet then B) Power.

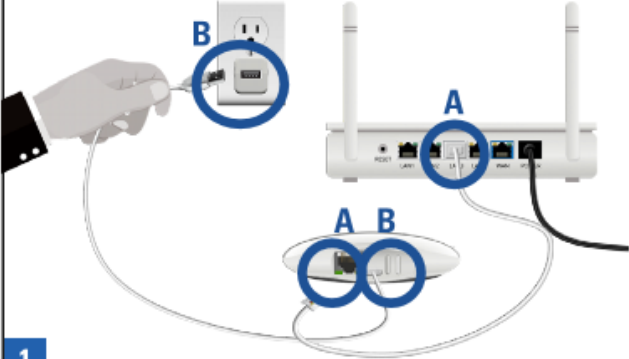

NOTE: Allow Hub to automatically seek, retrieve, and install firmware update. Hub LED sequence will go from blinking aqua, to solid amber, to blinking amber. **Do not interrupt this process.** After a firmware update, Hub will reboot. Firmware update may take several minutes.

1

OPEN PowerView® App. **SELECT New Hub.**

Set Up Hub

A new PowerView Hub has been detected on your network. Would you like to set up this Hub?

AVAILABLE HUBS

 New Hub Hub Gen 2	Set Up
---	---------------

2 [My Hub Isn't Shown Here](#)

SELECT New Setup.

in your network. Would you like to set up this Hub?

New Hub Found

New Setup

Set Up from Hub Backup

Cancel

3 secondary Hubs will appear under "Available Hubs"

Follow setup sequence as instructed in App.

Any Remotes to Set Up?



NOTE: When fully completed, Hub light will turn solid blue.

4



POWerview APP/HUB SETUP & OPERATION

HUB SETUP: WIRELESS

Complete the **Wired Setup** PRIOR to beginning the following steps.

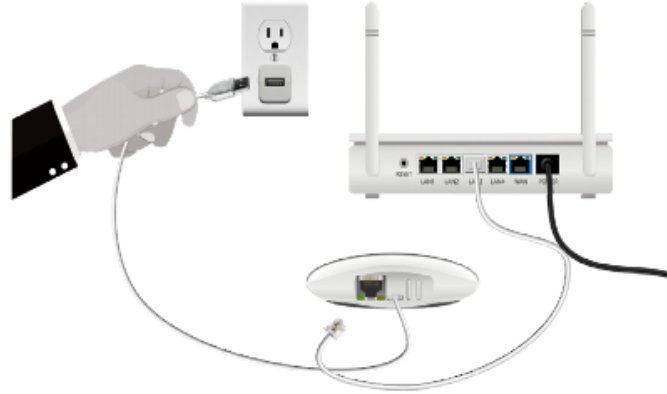

1

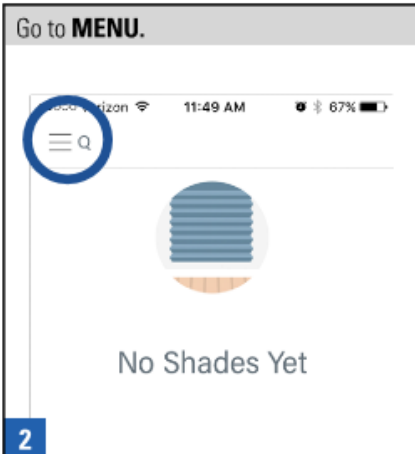

2

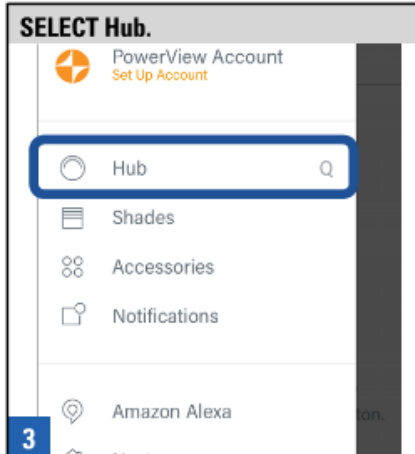

3

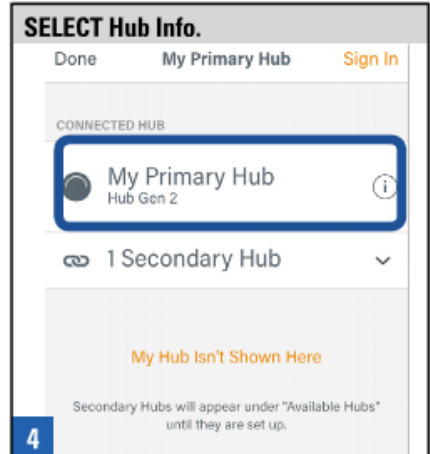

4

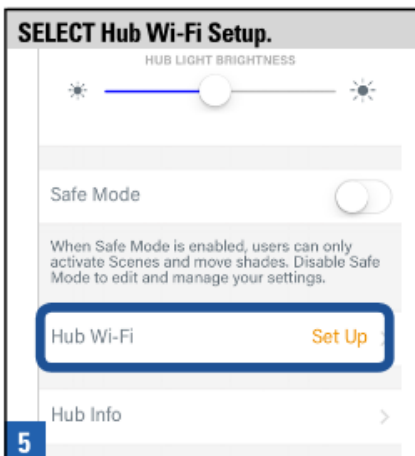

5

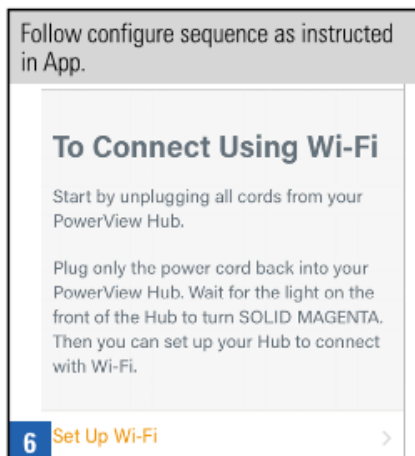

6



POWerview APP/HUB SETUP & OPERATION

SECONDARY HUB SETUP: WIRED

A secondary Hub may be introduced to your PowerView network to extend the reach and strength of the network. Naturally, a secondary Hub is any Hub that is setup after a first, i.e., primary, Hub has established a PowerView network. A primary Hub will be identified by its solid blue LED. Any secondary Hub will be identified by its solid green LED. The primary Hub should be connected to power and its LED should be solid blue before setting up a secondary Hub.

CONNECT secondary Hub to: A) Ethernet then B) Power.

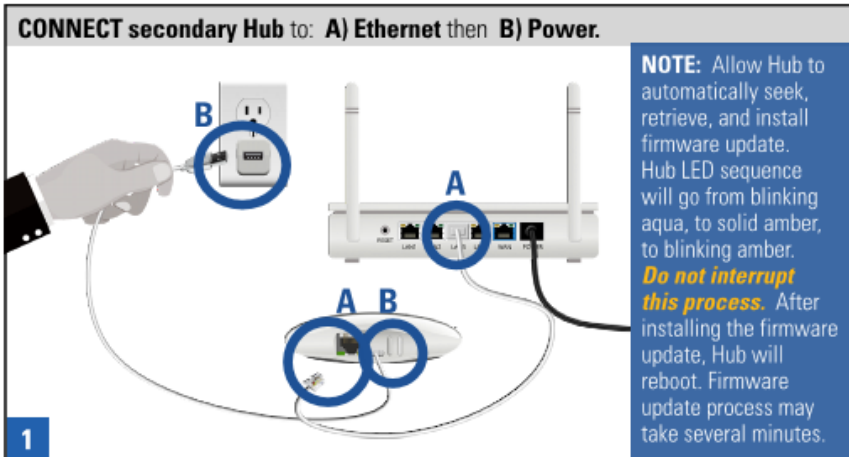

NOTE: Allow Hub to automatically seek, retrieve, and install firmware update. Hub LED sequence will go from blinking aqua, to solid amber, to blinking amber. **Do not interrupt this process.** After installing the firmware update, Hub will reboot. Firmware update process may take several minutes.

1

The Hub will automatically configure as a **secondary Hub**.



NOTE: When fully configured, the Hub LED will turn solid green.

2

In App, **OPEN Menu. SELECT Hub.**

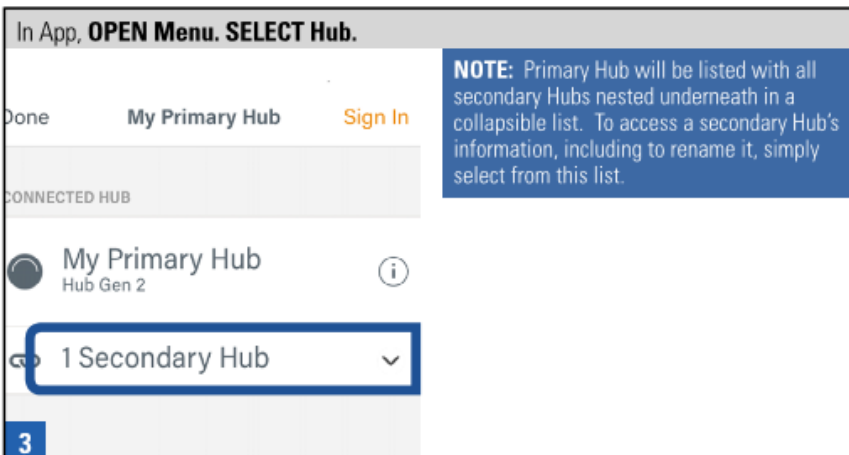

NOTE: Primary Hub will be listed with all secondary Hubs nested underneath in a collapsible list. To access a secondary Hub's information, including to rename it, simply select from this list.

3



POWerview APP/HUB SETUP & OPERATION

SECONDARY HUB SETUP: WIRELESS

A secondary Hub may be introduced to your PowerView network to extend the reach and strength of the network. Any secondary Hub will be identified by its solid green LED. The primary Hub should be connected to power and its LED should be solid blue before setting up a secondary Hub. Wireless secondary Hubs can be placed in more convenient locations within the home without being tethered to a router.

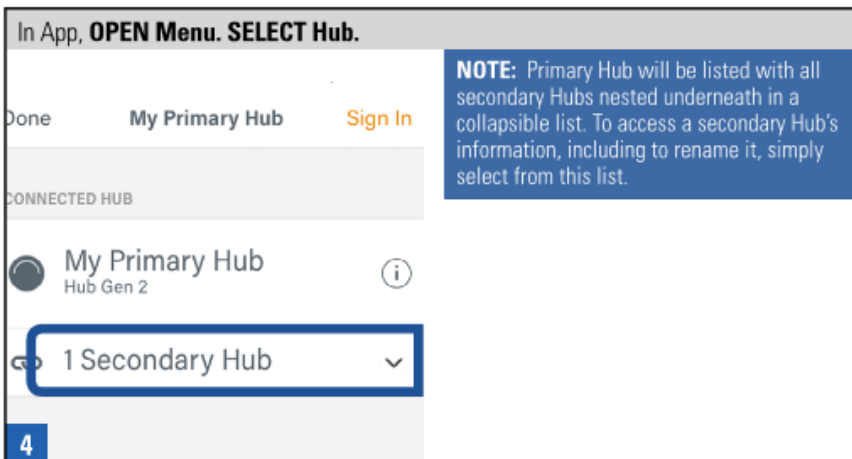
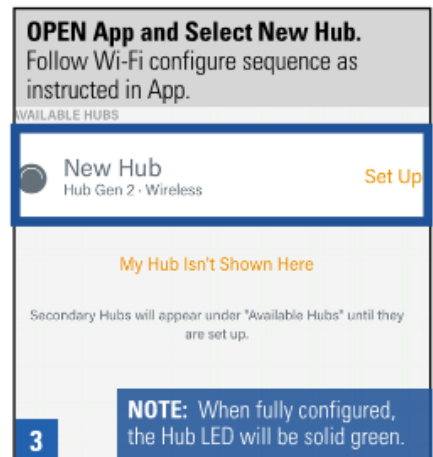
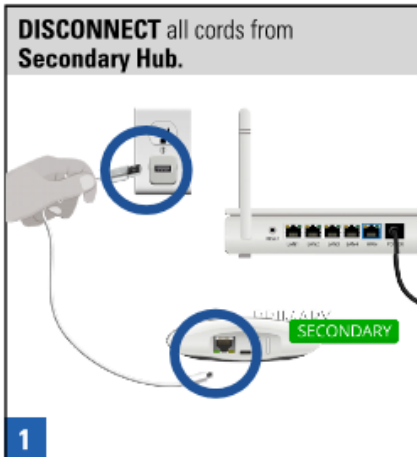

POWerview APP/HUB SETUP & OPERATION

PAIRING A REMOTE TO A POWerview NETWORK USING THE HUB

A Hub previously paired to an existing remote network or that had created its own network during setup can have additional remotes paired to it, even if the remotes are introduced after the initial Hub setup. This is especially beneficial when a customer using the PowerView App and a single remote (Pebble or Surface) needs to replace the remote with a new one. In this instance, any newly introduced remote must be paired to the Hub to avoid having multiple PowerView Shade Networks in use.

Caution: In this scenario, any shades previously operated by the remote will need to be re-joined to a Group number (1-6) on the remote. Whenever possible, it is always best to pair remotes to a Hub during the initial Hub and App setup procedure or before joining any shades to Group numbers on the remote.

Using a paper clip, **PRESS** and **HOLD** the recessed programming button for 6-10 seconds. Remove back cover, if necessary.



1

NOTE: The Group Numbers (1-6) will flash twice on the press of the programming button then three times at six seconds.

Complete steps 2 and 3 at the same time, HOLDING the remote module close (within 12 inches) to the Hub.

a. **PRESS** and **HOLD** ■ (Stop) button on remote module.
b. **PRESS** the "P" button on the back of the Hub for approximately 3 seconds.

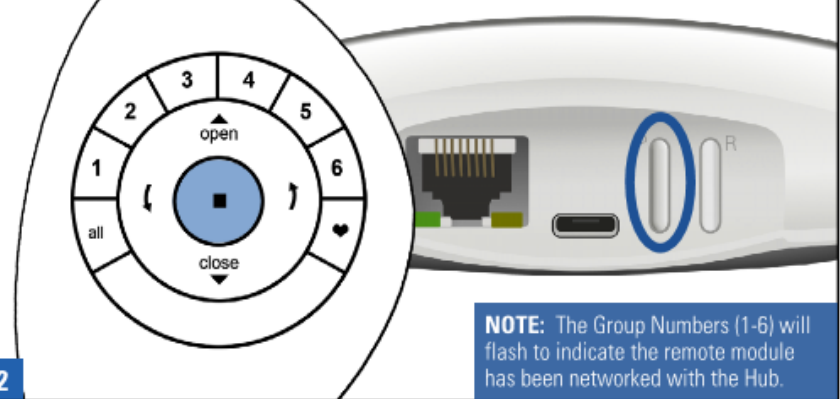

2

NOTE: The Group Numbers (1-6) will flash to indicate the remote module has been networked with the Hub.



POWerview APP/HUB SETUP & OPERATION

POWerview ACCOUNT

A PowerView account is optional. However, it is required for any household wishing to use advanced features offered through the PowerView App. Once an account is created and verified, it is important to register the Hub. Registering the Hub links the Hub to your PowerView account, permits access to Scenes and Automations via RemoteConnect, and enables integration of PowerView with compatible 3rd party control systems and devices (ex . Nest, Control4, etc .)

ACCOUNT SETUP

1 TAP Menu. The app shows a menu with a hamburger icon circled in blue. Below the menu is a large illustration of a hand holding a smartphone.

2 TAP PowerView Account. The app displays a 'PowerView Account' section with a 'Set Up Account' button circled in blue.

3 SELECT Create Account. The app shows a 'Nest Access' section with a 'Create Account' button circled in blue.

4 Verify Account. The app displays a 'Verify Account' screen with a 'Confirm Your Email Address' button circled in blue. A note at the bottom states: 'Note: A confirmation email will be sent to your email address.'

5 Sign in to Account. The app shows a 'Sign in to PowerView' screen with fields for 'Email Address' and 'Password', and a 'Forgot Password?' link.

REGISTER HUB (REQUIRED FOR REMOTECONNECT & 3RD PARTY CONTROL SYSTEM INTEGRATION)

1 TAP Menu. The app shows a menu with a hamburger icon circled in blue.

2 TAP Hub. The app displays a 'Hub' section with a 'Hub Josh Example Hub' button circled in blue.

3 TAP Hub Info. The app shows a 'Hub Info' section with a 'Hub Info' button circled in blue.

4 TAP Register Hub. The app displays a 'Register Hub' screen with a 'Register Hub' button circled in blue.



POWerview APP/HUB SETUP & OPERATION

DASHBOARD

The Dashboard in the PowerView App displays favourite Shades, Scenes, and Automations, and is the landing screen when opening the PowerView App. The quick glance access available from the Dashboard makes it easy to activate a favourite Scene or adjust the position of favourite Shade, without the need to navigate to multiple screens within the App. Build a custom Dashboard by adding or removing favourite Shades, Scenes, and Automations as desired. Dashboard favourites are specific to the user's device.

ADDING A FAVOURITE

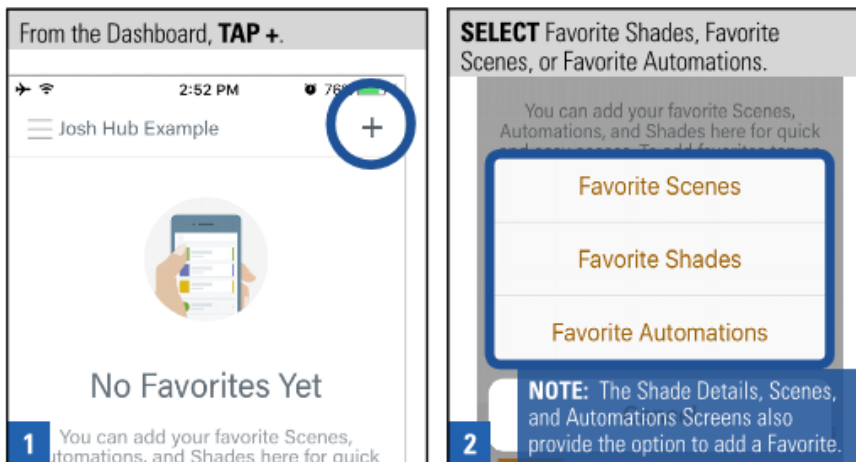

DELETING A FAVOURITE

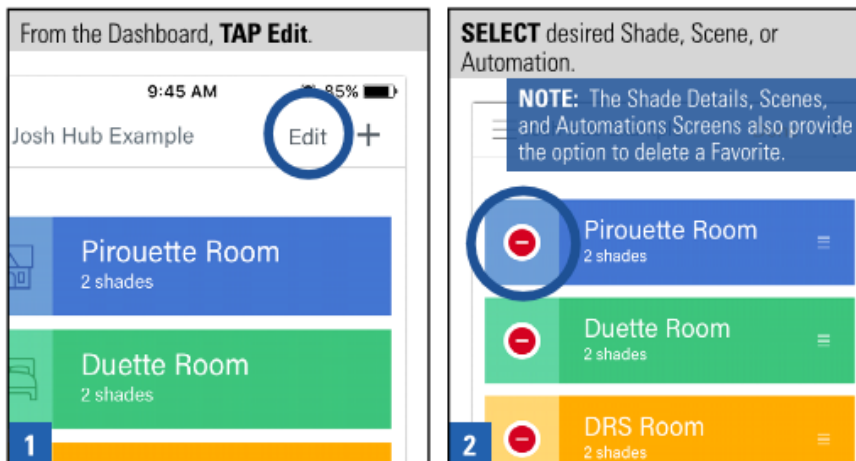

POWERSVIEW APP/HUB SETUP & OPERATION

DISCOVER SHADES

To explore the variety of functions offered in the PowerView App, a PowerView window covering must be visible in the App. To make a PowerView window covering visible, use the Discover function.

Once a PowerView window covering has been discovered, it will be listed in the Shades screen found in the Menu and be operable using the PowerView App. Also, when a window covering is discovered by the Hub, it will automatically be joined to that Hub's PowerView Shade Network. Any PowerView window covering not yet joined to a Hub or to a Group number (1-6) on a remote is discoverable. In addition, any PowerView window coverings previously joined to a Group number (1-6) on a remote that has also been paired to the Hub, will be discoverable.

NOTE: The PowerView Hub will not discover any PowerView window covering already joined to a PowerView Shade Network. Therefore, before using the Discover function in the App or joining a window covering to a Group number (1-6) on the remote, pair all remotes to the Hub.

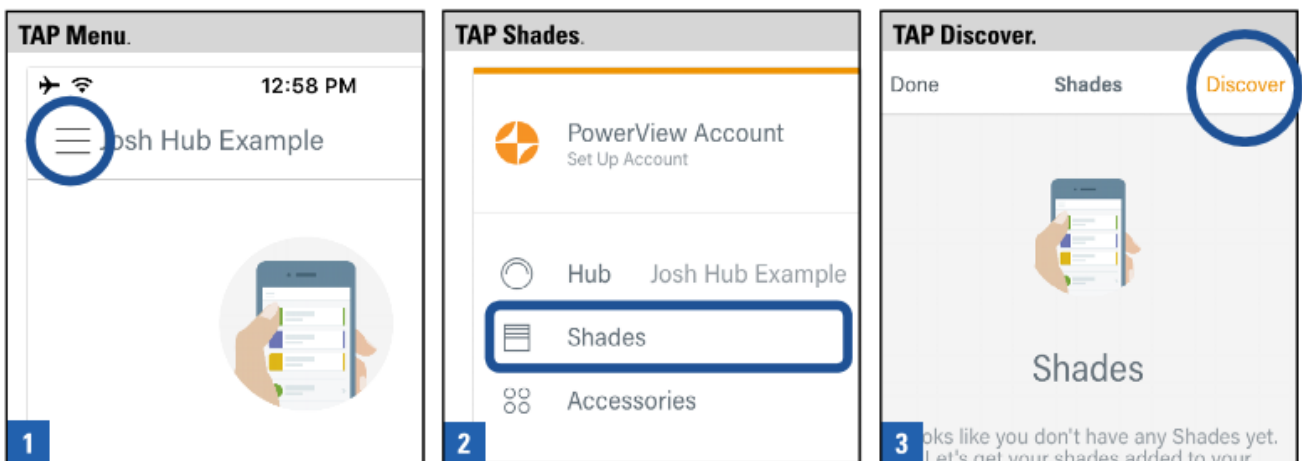

POWerview APP/HUB SETUP & OPERATION

EDITING SHADE DETAILS

In the Menu you will find a list of all the PowerView Shades Discovered by the Hub. Each Shade has its own Shade Details screen. The Shade Details screen allows you to do the following: give a shade a custom name; jog a shade to identify and establish the shade's physical location within the home; assign a shade to a Room; refresh a shade's battery status; check the strength of a shade's radio frequency status; and add a shade to Favourites.

NOTE: Consult with a Hunter Douglas professional installer or Customer Service Representative before using the Advance Features options in Shade Details.

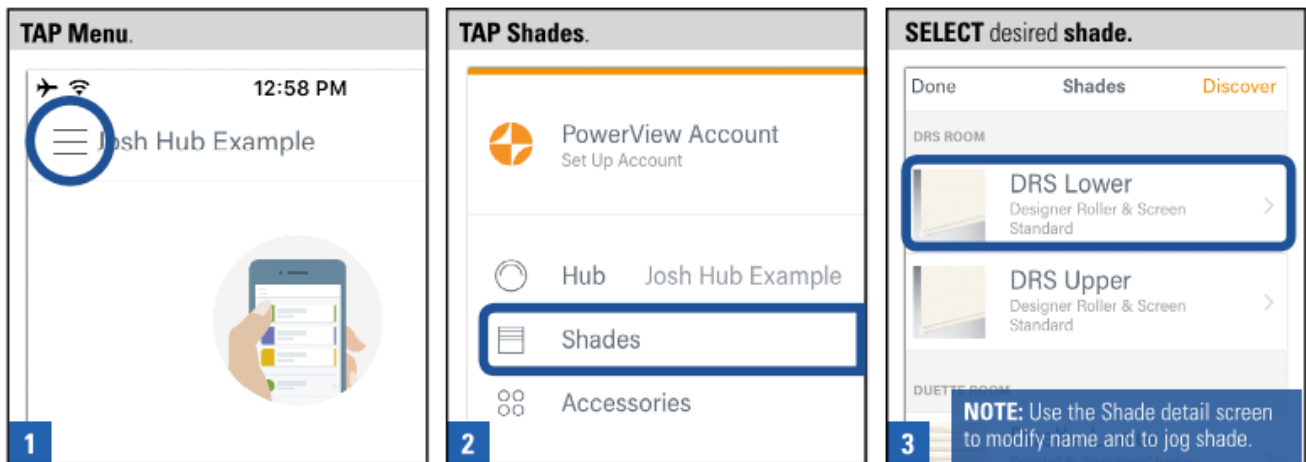

POWerview APP/HUB SETUP & OPERATION

CREATING & DELETING ROOMS

A Room must be created to create a Scene . A Room can have multiple shades assigned to it. However, a shade cannot be assigned to multiple Rooms. Rooms can be customized by name, icon, and colour in the PowerView App.

CREATE A ROOM

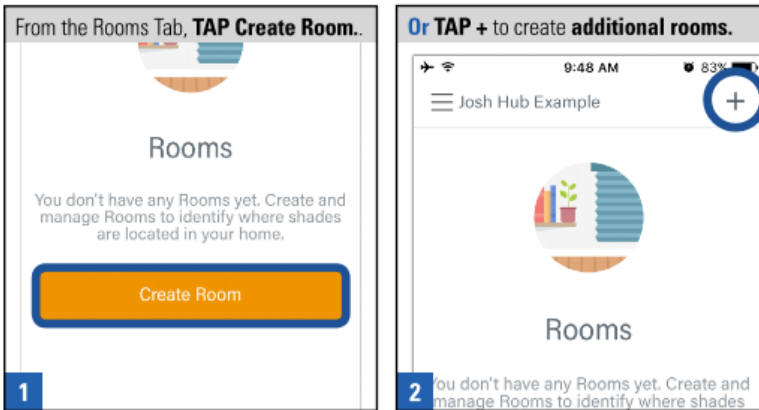

DELETE A ROOM

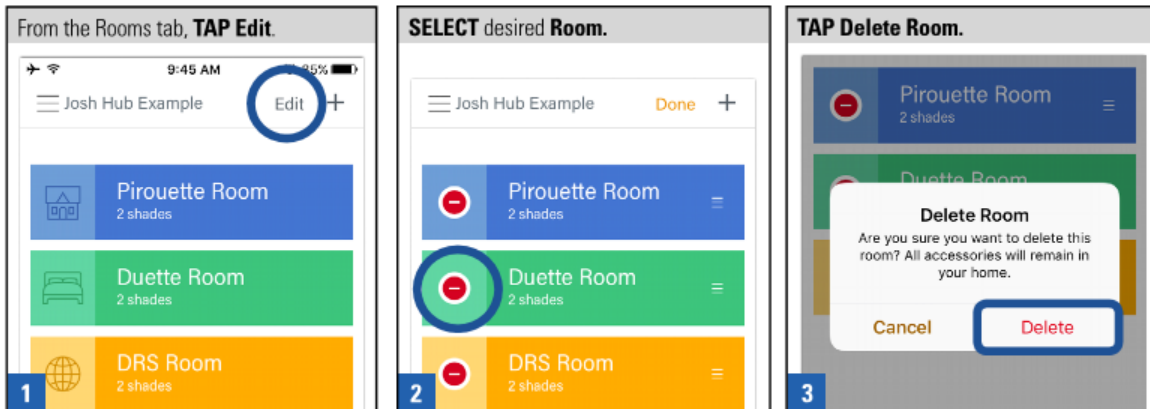

POWerview APP/HUB SETUP & OPERATION

ASSIGNING SHADES TO ROOMS

Any PowerView window covering listed in the PowerView App as a Shade can be assigned to a Room. A Room can have multiple Shades assigned to it; however, a single shade cannot be assigned to multiple Rooms. The App offers two methods to assign a Shade to a Room.

FROM ROOMS TAB



FROM MENU

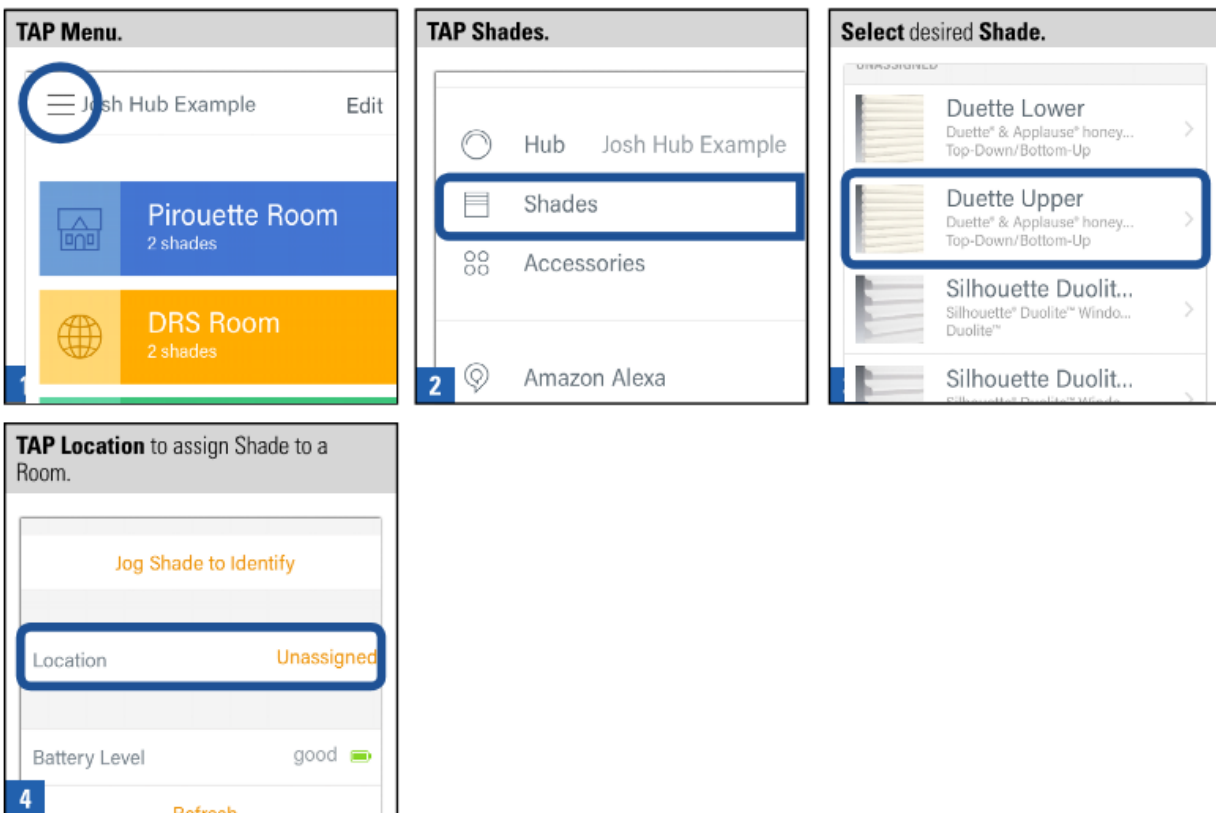

POWerview APP/HUB SETUP & OPERATION

SHADE OPERATION

There are multiple ways to operate a Shade in the PowerView App. They include: jogging a shade (for shade identification in the home); operating a Shade in a Room; operating a Shade via a Scene; Operating a Shade via an Automation.

SHADE OPERATION IN A ROOM

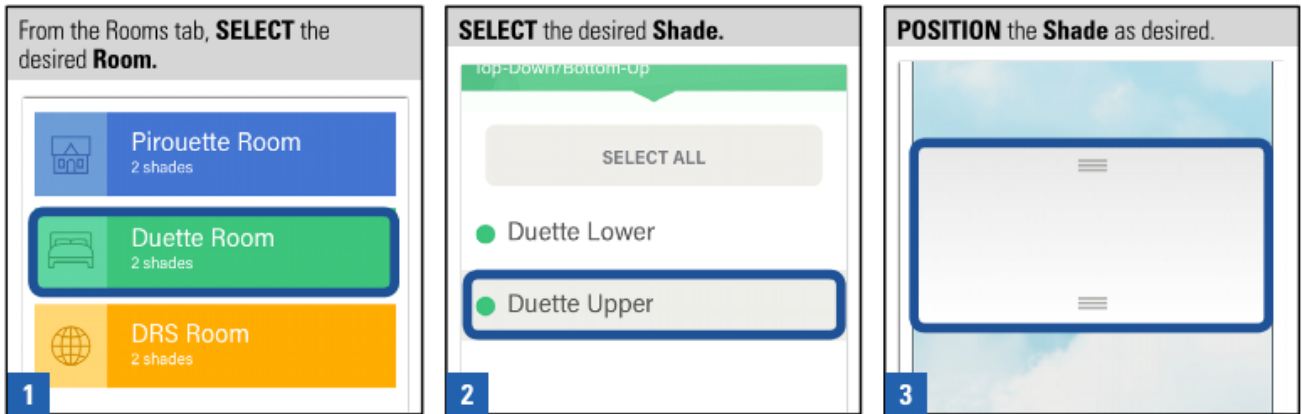

SHADE OPERATION VIA A SCENE

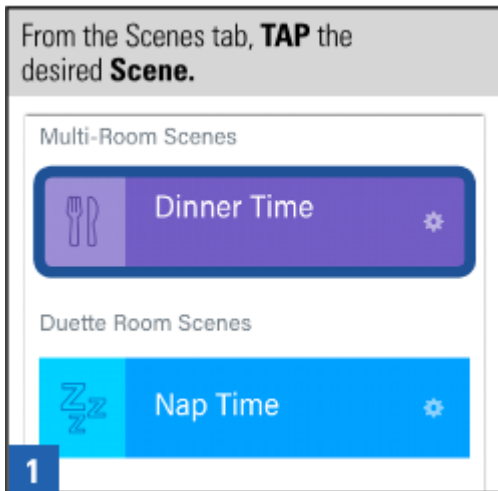

SHADE OPERATION VIA AN AUTOMATION

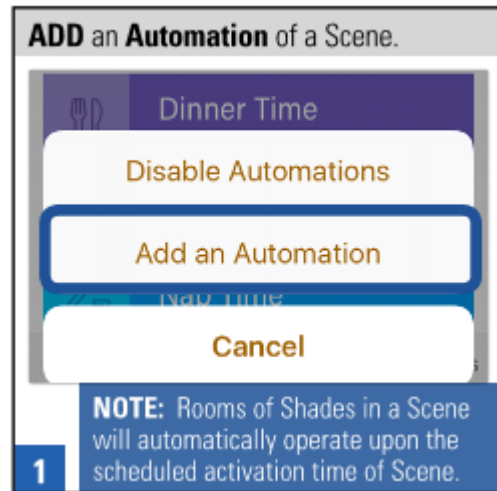

JOGGING A SHADE

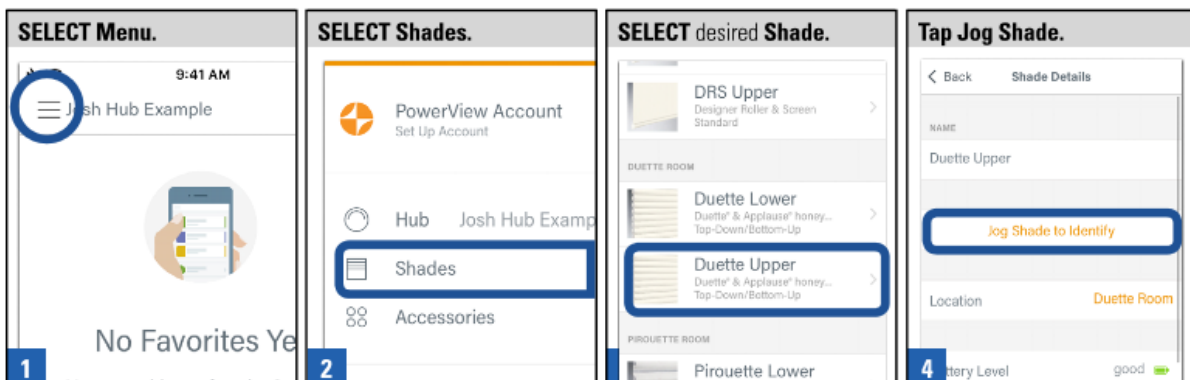

POWerview APP/HUB SETUP & OPERATION

CREATING, OPERATING & DELETING SCENES

Rooms are required to create Scenes in the PowerView App. Scenes can be added to Favourites for easy access on the Dashboard.

CREATE A SCENE

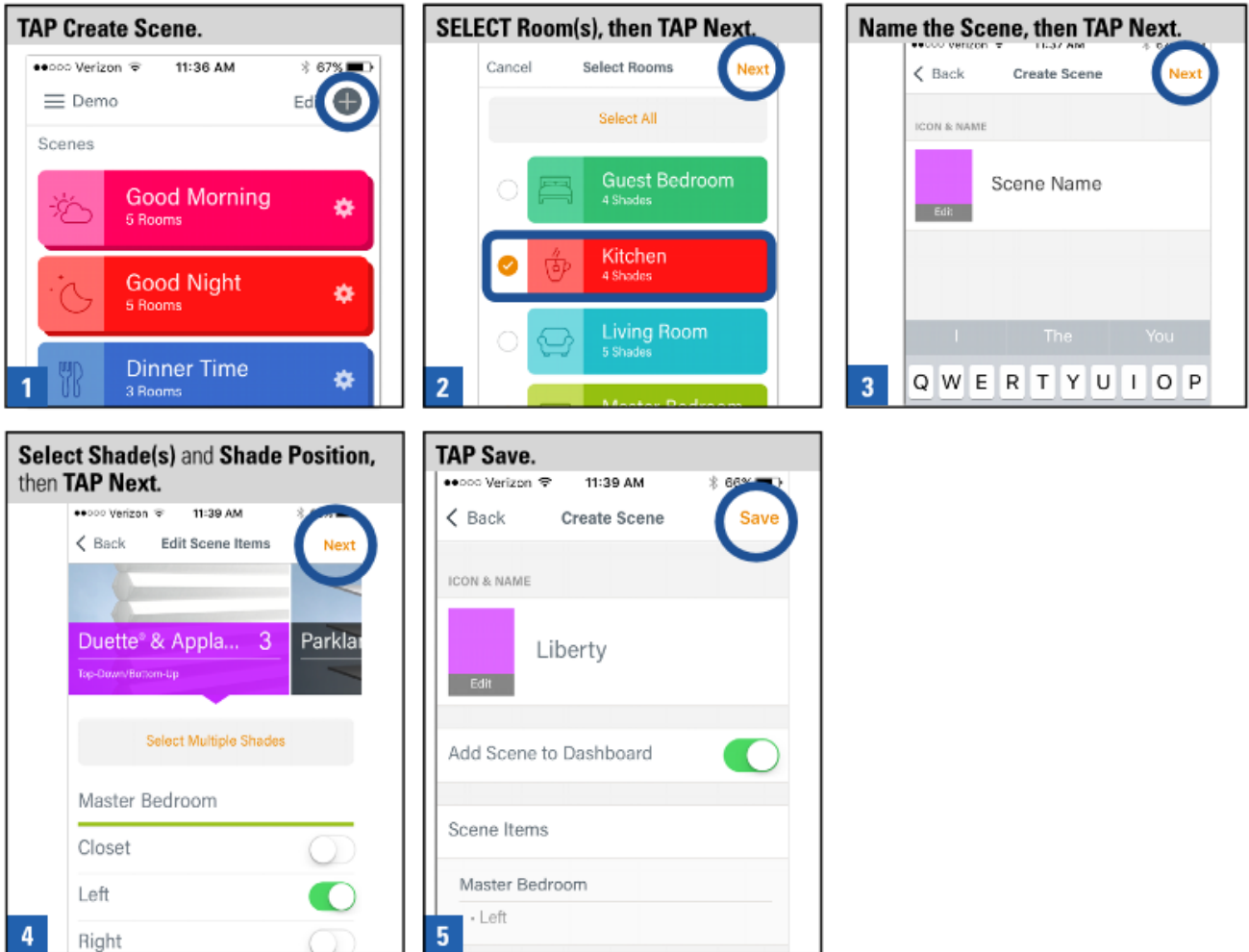

OPERATE A SCENE

DELETE A SCENE

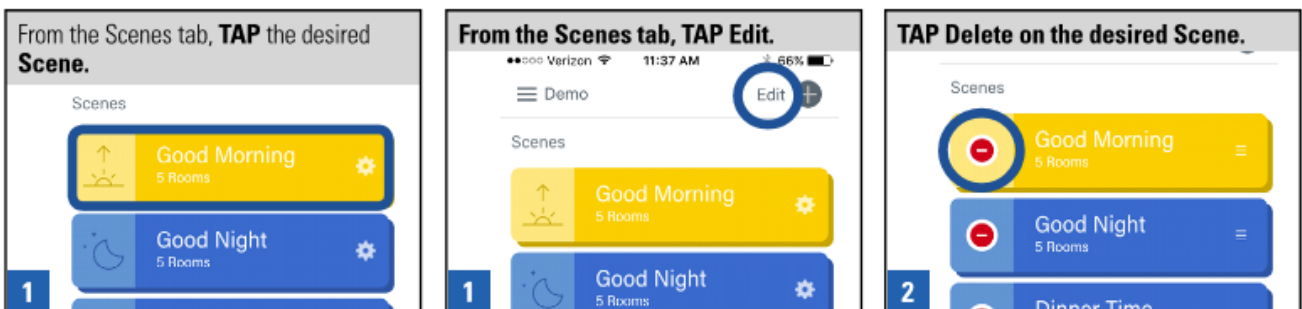

POWerview APP/HUB SETUP & OPERATION

CREATING, ENABLING, DISABLING & DELETING AUTOMATIONS

The Automations function allows for scheduled activation of Scenes. Scenes are required to create Automations. Assign days and times of the week for each Automation. Automations can be added to Favourites for easy access on the Dashboard.

CREATE AN AUTOMATION

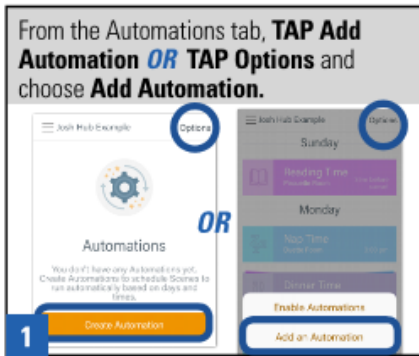

DISABLE A SINGLE AUTOMATION

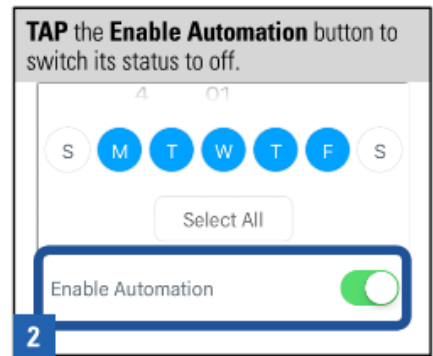
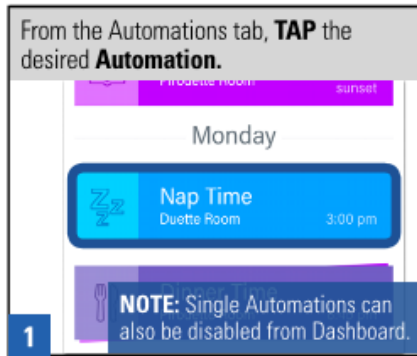

DISABLE ALL AUTOMATIONS

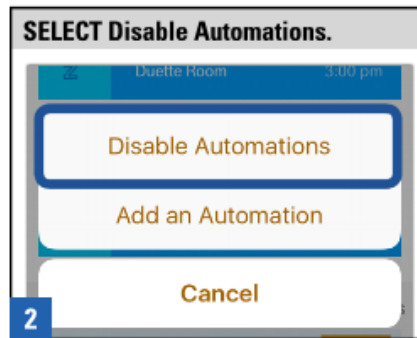
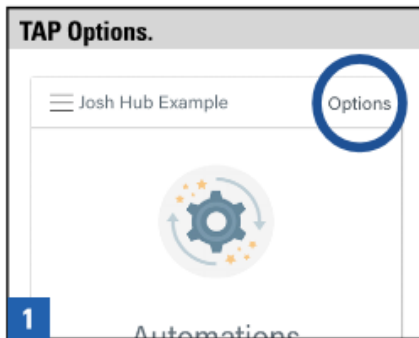

TO DELETE AN AUTOMATION

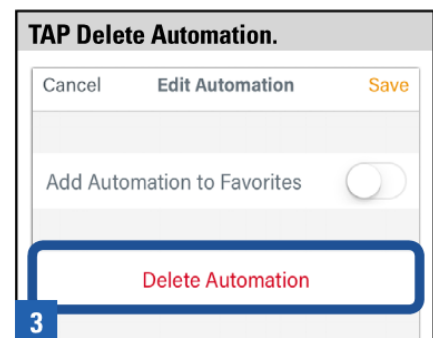
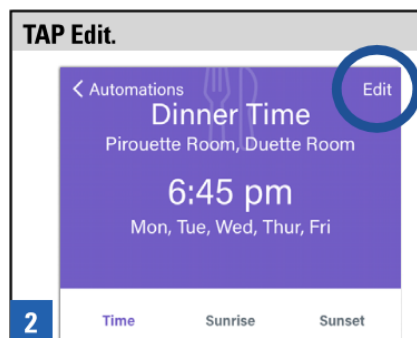
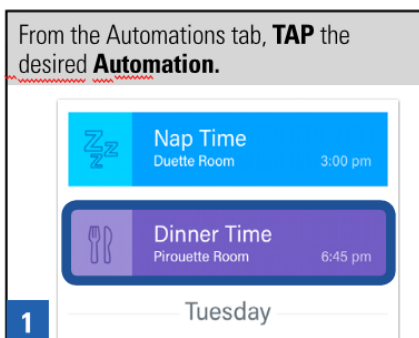

POWerview APP/HUB SETUP & OPERATION

AUTOMATIONS: SUNRISE/SUNSET

The Automations function allows for scheduled Sunrise or Sunset activation of Scenes. The Sunrise and Sunset Automations feature requires access to your smart device's geo-location before any Automation can be scheduled using the Sunrise or Sunset feature. To enable this feature in the PowerView App, access your smart device's settings and open the PowerView App to change the device's Location status.

1 From the Automations tab, **SELECT** the desired **Automation** **OR TAP** Add an Automation to create one.

2 Choose **Sunrise** or **Sunset**.

3 **SELECT** the **day(s)** this Automation will be activated.

4 Ensure **Enable Automation** is selected.

NOTE: Move the Before, At, After slider to refine the timing.



POWERSVIEW APP/HUB SETUP & OPERATION

USING REMOTECONNECT

RemoteConnect is a standard feature of your PowerView account and is automatically enabled with the creation of a PowerView account. Use RemoteConnect when you're away from home to remotely access and activate Scenes and Automations in the PowerView App on your smart device.

NOTE: A registered Hub and verified PowerView Account are required to use RemoteConnect.

ACCESS SCENES & AUTOMATIONS

1 TAP Connect to Hub.
We were unable to find a PowerView® Hub on your network. You must connect to a PowerView Hub to utilize the full benefits of the PowerView® App.
You can also try a Demo to explore some of the features of the PowerView App.
Buttons: **Connect to Hub**, **PowerView Demo**

2 Select Hub.
Or, use your PowerView Account to access your Hub with RemoteConnect™.
HUBS
Josh Example Hub
Hub Gen 2 · RemoteConnect™ **Connect**
My Hub Isn't Shown Here
NOTE: RemoteConnect will be labeled below the Hub's name. If Hub is not found, sign in to your account.

3 SELECT Scene or Automation.
Rooms **Scenes** Automations
NOTE: RemoteConnect will be labeled below the Hub's name near menu. Dashboard and Rooms will be unavailable.



SCENE CONTROLLER



SCENE CONTROLLER

ADDING A NEW SCENE CONTROLLER

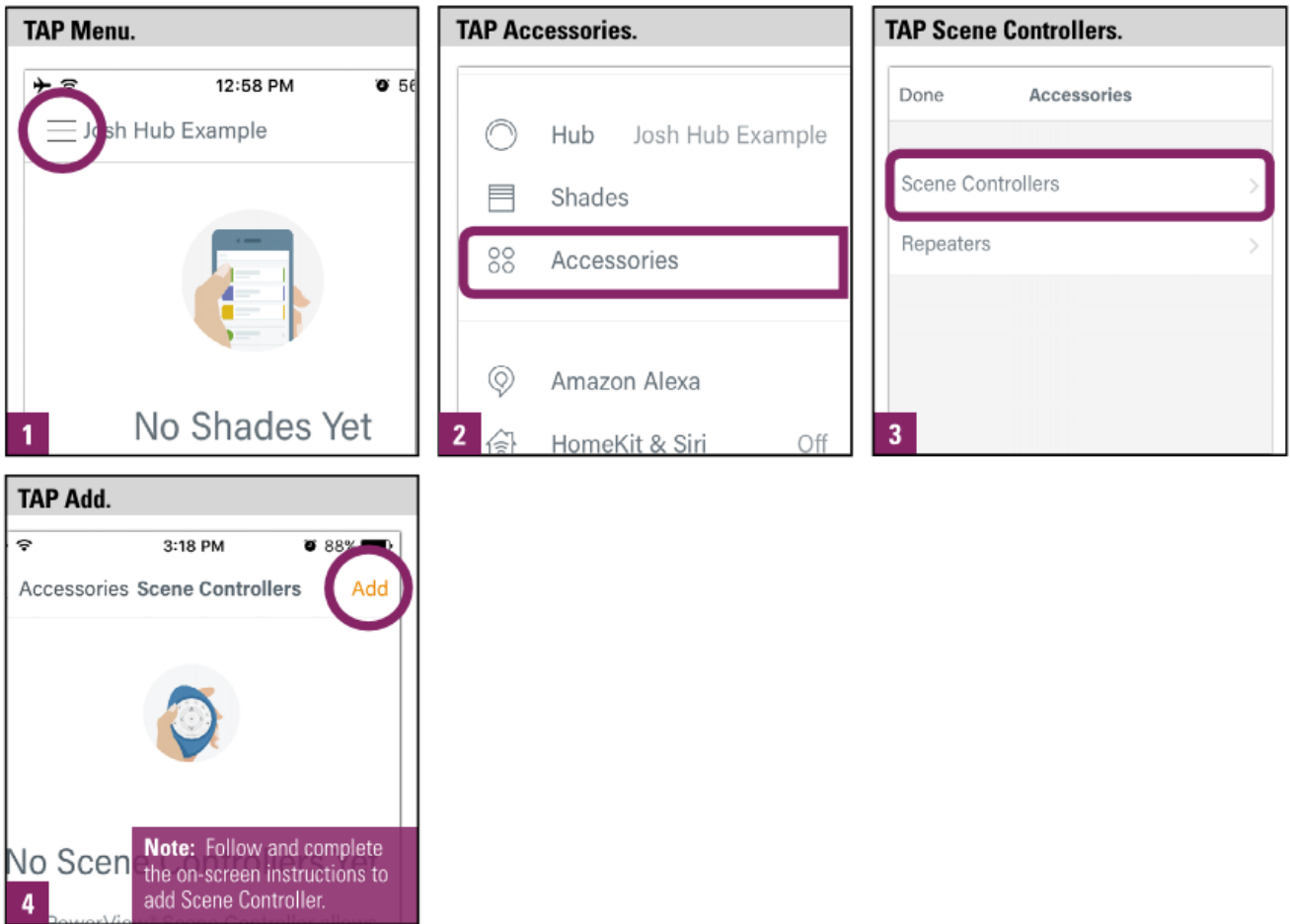

SCENE CONTROLLER

ADDING & CONFIGURING SCENES IN A SCENE CONTROLLER

A Scene Controller does not create Scenes. Scenes previously created in the PowerView App can be added to or removed from a Scene Controller, as desired.

1 TAP Menu.

2 TAP Accessories.

3 TAP Scene Controllers.

4 SELECT desired Scene Controller.

5 TAP Select Scenes.

6 TAP Rearrange.

7 TAP Updating Scene Controller.

Use handles to rearrange the desired order of the Scenes. Use the heart and double heart icons to set favorites.

Follow instructions in App to complete this process. Newly added Scenes will be displayed, de-selected Scenes are removed.



SCENE CONTROLLER

OPERATING SCENES WITH THE SCENE CONTROLLER

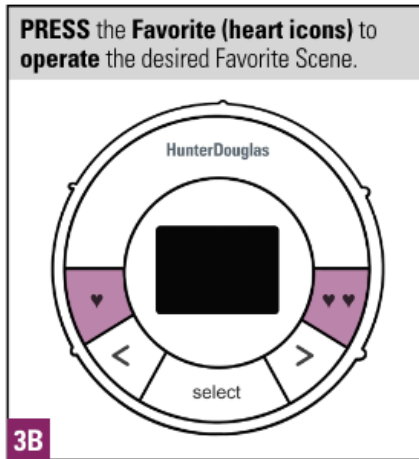
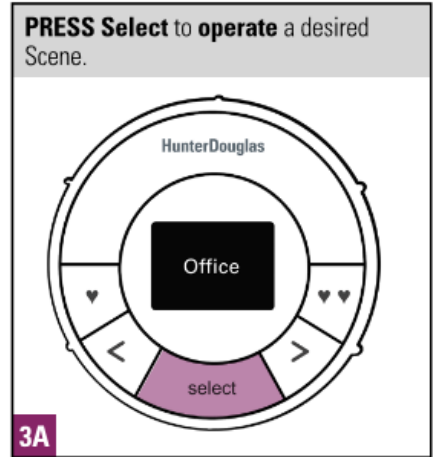
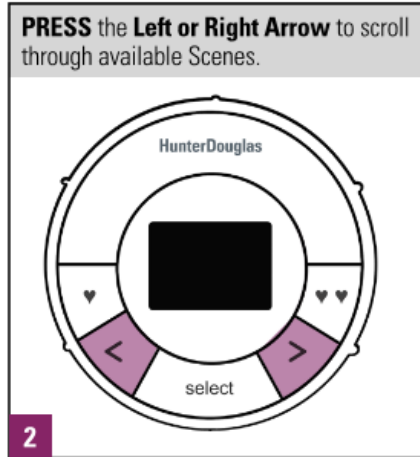
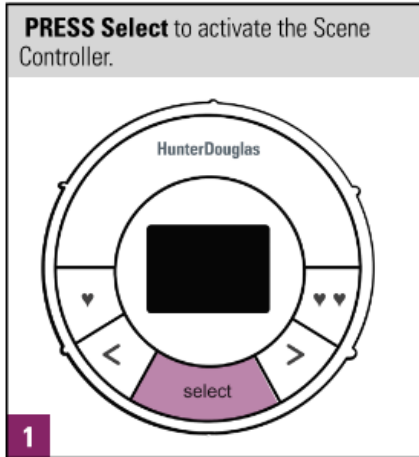

TROUBLESHOOTING



TROUBLESHOOTING

PERFORMING A PROGRAMMING RESET

This reset is used to erase all current programming stored in a window covering's headrail. This includes a reset of the PowerView Shade Network ID, the elimination of any Group assignments on a remote(s), and the removal of the window covering from the App. Completing a programming reset will prevent a PowerView Pebble Remote or mobile device from operating a window covering until it is reprogrammed (including re-Discovered in the App).

NOTE: This reset procedure DOES NOT clear the window covering's limits.

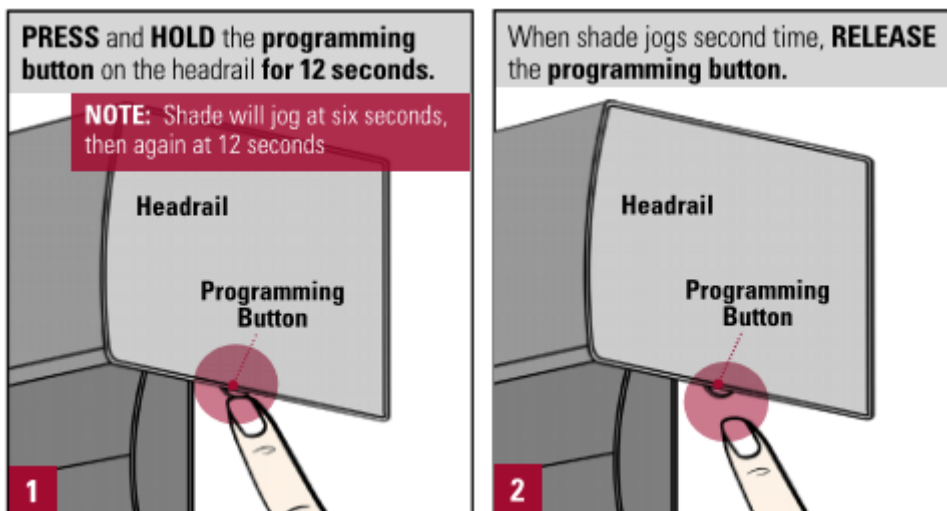

TROUBLESHOOTING

BACKING UP THE HUB

Backing up the Hub saves all Shades, Rooms, Scenes, Automations, and Hub information (including current Scene Controller settings) as a local file within the PowerView App on your device.

1. **TAP Menu**
2. **TAP Hub**
3. **TAP**
4. **TAP Hub Info**
5. **TAP Hub Backups**
6. **TAP Back-up**

EMAILING A HUB BACKUP

Backing up the Hub saves all Shades, Rooms, Scenes, Automations, and Hub information (including current Scene Controller settings) as a local file within the PowerView App on your device.

1. **TAP Menu**
2. **TAP Hub**
3. **TAP**
4. **TAP Hub Info**
5. **TAP Hub Backups**
6. **TAP Back-up**
7. **Select desired Hub Backup version**
8. **Select Email Backup**

RESTORING A HUB BACKUP

Backing up the Hub saves all Shades, Rooms, Scenes, Automations, and Hub information (including current Scene Controller settings) as a local file within the PowerView App on your device.

1. **TAP Menu**
2. **TAP Hub**
3. **TAP**
4. **TAP Hub Info**
5. **TAP Hub Backups**
6. **TAP Back-up**
7. **Select desired Hub Backup version**
8. **Select Restore Backup**



TROUBLESHOOTING

FREQUENTLY ASKED QUESTIONS

GENERAL

Q: How do I know if my Hunter Douglas window coverings have PowerView Motorization?

A: Any wireless motorized Hunter Douglas window covering manufactured after July 2015 is built with PowerView Motorization. Some exceptions may apply.

Q: Will my PowerView Pebble Remote work right out of the box?

A: No, a shade must first be joined to a group number (1-6) on a PowerView Pebble Remote in order to operate using a remote.

Q: Do I need a PowerView Pebble Remote or PowerView Surface Remote to operate my window treatments?

A: A PowerView Pebble Remote or PowerView Surface Remote is highly recommended in addition to using the PowerView App. These devices allow for alternate control for individual and groups of shades and are artfully designed to complement any home décor.

Q: Do I need to run wires?

A: No wiring is necessary for products with PowerView Motorization. Hunter Douglas offers a variety of power options including battery and plug-in power supplies to fit any application. Hunter Douglas offers 18v D.C. power supply option.

Q: Can I wirelessly control my Hunter Douglas motorized shades from my home automation system?

A: With the addition of the PowerView Hub, Hunter Douglas PowerView window treatments can be integrated into a home automation system via using IP (Internet protocol). A PowerView account is required. Register the Hub after creating a PowerView account.

Q: What are the available colours for the PowerView Pebble?

A: The PowerView Pebble is available in a variety of on-trend colours and finishes. Black Matte, Citron, Clear Frost, Cobalt, Pewter, Frost, Poppy, Ecru, Oyster, Mist and White.

Q: What are the available colours for the PowerView Surface?

A: The PowerView Surface is available in White Matte, Black Matte and Nickel Matte.

Q: How long can I expect the batteries to last for my battery-powered motorized window covering?

A: Battery life for PowerView motorized window treatments using the AA battery wand exceeds one year, depending on shade, size, configuration and usage. Rechargeable batteries are not recommended. Hunter Douglas recommends alkaline batteries for all products with the exception of Duette shades with the SkyLift System, where we recommend using Energizer* Ultimate Lithium AA batteries.

*Energizer is a trademark of Eveready Battery Company, Inc.



TROUBLESHOOTING

FREQUENTLY ASKED QUESTIONS

NETWORKING

Q. What is a PowerView® Shade Network?

A. PowerView is a proprietary wireless radio frequency (RF) communication language from Hunter Douglas. Similar to the Wi-Fi network in your home, the PowerView Shade Network refers to a unique PowerView RF ID that allows communication between all the PowerView devices that share this unique RF ID.

Q. What is pairing to a network?

A. Pairing refers to joining multiple PowerView remotes with each other or with the Hub to form a unified PowerView Shade Network. It is recommended that all PowerView window coverings and control accessories in the home (remotes, repeaters, and Hub) be paired to one, unified network so they all communicate using the same PowerView Shade Network ID.

Q. When should I pair?

A. It is recommended that remotes be paired any time there are multiple PowerView remotes in a home. Always pair all PowerView remotes to one, unified Single Network ID at the beginning of every PowerView installation. This eliminates problems should the PowerView Hub be introduced later. If an order comes with the multiple remotes AND a Hub, pair all remote devices first, then complete the Hub setup procedure as directed through PowerView App. Doing so will ensure the Hub is paired to the Network ID already established.

Q. Why would all my PowerView items window coverings and control accessories need to be on the same network?

A. A consequence of not having all PowerView window coverings and control accessories on the same network is that a PowerView Hub only recognizes one PowerView Shade Network. If a Hub is introduced after you have Grouped shades to one or more remote devices (ex . Pebble or Surface remotes) that have not been paired to the same PowerView Shade Network, then the Hub will be unable to Discover or communicate with all or some of the PowerView window coverings, remotes, and/or repeaters in the home. By having one, unified Single Network ID, the PowerView Hub will be capable of Discovering and communicating with all the PowerView window coverings and control accessories in the home that are on the network, even if separate remotes are used to operate different rooms of shades.

Q. How is duplicating a remote different from pairing a remote to another remote?

A. Duplicating takes all of one remote's information (Groups, Favourite, and radio frequency PowerView Shade Network ID) and copies that exact information onto another remote .This allows the user to have multiple, interchangeable remotes to operate the same Groups of shades, regardless of which remote is used. Pairing, on the other hand, does not copy a remote's Groups or Favourite information to another remote. Instead, pairing places multiple remotes on a single, unified PowerView Shade Network for the home.



TROUBLESHOOTING

FREQUENTLY ASKED QUESTIONS

POWerview PEBBLE REMOTE & SURFACE REMOTE

Q: Can I purchase additional PowerView Pebbles, Remotes or Scene Controllers?

A: Additional PowerView Pebble and Surface mounts can be ordered if desired. Remotes and Scene Controllers cannot be ordered individually; they must be ordered either with a Pebble or Surface mount.

Q: What does the Favourite button on the PowerView Pebble Remote do?

A: A Favourite position can be created and set for each of the six group buttons on the PowerView Pebble Remote or PowerView Surface Remote. The Favourite button is a quick and easy way to send shades to a specific, pre-set position. There is one Favourite position per shade that comes pre-set at 50% of the shade's travel.

Q: How many shades can I control using the PowerView Pebble Remote or PowerView Surface Remote?

A: A PowerView Remote can be used to operate six shades individually or hundreds of shades as a group, as long as the shades can receive commands from the remote.



TROUBLESHOOTING

FREQUENTLY ASKED QUESTIONS

POWerview APP

Q: What devices are compatible with the PowerView® App?

A: The PowerView App is compatible on Android (running version 4 .4 and newer) and Apple (running version 10 .0 and newer) mobile devices.

Q: Do I need an Internet connection to set up the PowerView App to control my window treatments?

A: No, an Internet connection is not necessary. A home router, however, is required to set up the PowerView Hub and App via Wi-Fi.

Q: What is RemoteConnect?

A: RemoteConnect is a standard feature of the PowerView Account that allows users to control their window treatments from outside of the home using data or a Wi-Fi connection. To use RemoteConnect open the PowerView App, create a PowerView Account, then register the Hub.

Q: What is a Room in the PowerView App?

A: Rooms allow for custom organization and arrangement of PowerView shades discovered by the PowerView App. Once a shade has been discovered in the PowerView App, it can be assigned to a Room. Within a Room, users can control individual shades or groups of the same shade type by using the product specific slider.

Q: What is a Scene in the PowerView App?

A: A Scene is used to operate a single shade or multiple shades assigned to a Room. Shades in a Scene can be programmed to a pre-set position within the window (ex . vanes open or shade fully raised) so that anytime the Scene is activated, the shades will move to their pre-set positions. For example, a Scene called "Goodnight" can be created in which all of the shades in a particular Room move to the closed position when that Scene is activated.

Q: What is an Automation in the PowerView App?

A: An Automation is timed, automatic activation of selected Scenes and Multi-Room Scenes . Users can set a custom schedule for any Automation they create. Once an Automation is set, the user is not required to manually activate it.

Q: Will Automations work even if my mobile device is not at home?

A: Yes, Automations will continue to operate shades at the set time(s) of day even if the wireless device is not in the home. All scheduling data is stored in the PowerView Hub.

Q: Do Automations automatically change for Daylight Savings Time?

A: Yes, Automations update automatically for Daylight Savings Time.

Q: Are there any service fees associated with App features?

A: Hunter Douglas does not charge any additional fees for App updates. For features that use your mobile wireless network, check with your carrier for data rate charges that may apply.



TROUBLESHOOTING

FREQUENTLY ASKED QUESTIONS

POWerview APP

Q: Can I reset or adjust the limits on my PowerView window covering using the App?

A: To reset or adjust a window covering's upper and lower limits using the App, go to the Shade Detail information screen in the App for the shade in question. Then, select Show Advanced Options and choose Calibrate Shade to clear and reset the upper and lower limits. The shade will run fully up and down. Do not interrupt this process.

Q: I have to replace a PowerView window covering with a brand new one. Will it still remain in the App even after I've replaced it?

A. If a PowerView window covering needs to be replaced, it will be necessary to delete it from the App using the Delete Shade command found under the Show Advanced Options in the Shade Detail screen. Deleting a window covering using this command purges the Hub of that window treatment's data. If the replaced window covering is not deleted, then the App will continue to show that window covering in the various Room(s) and Scene(s) to which it was assigned. After the new window covering is installed, Discover it and assign it, as desired, to the appropriate Room(s) and Scene(s), as desired.



TROUBLESHOOTING

FREQUENTLY ASKED QUESTIONS

POWERSVIEW HUB

Q: What Wi-Fi routers work best with the PowerView Hub?

A: The PowerView Hub is designed to work with consumer-grade Wi-Fi routers operating on 2.4 GHz. However, security settings or special configurations may affect communication with the Hub.

Q: Are Hub firmware updates sent to Secondary hubs the same time the update is sent to the Primary Hub?

A: Hub firmware updates are automatically pushed to Secondary Hubs from the Primary Hub.

Q: Can I change the Wi-Fi network my PowerView Hub is connected to?

A: Yes! The option to forget the current Wi-Fi network the PowerView Hub is connected to can be found in the Hub menu of the PowerView App. Once the current Wi-Fi network is forgotten, the Hub can be connected to a new network.

POWERSVIEW SCENE CONTROLLER

Q: What is the PowerView Scene Controller?

A: The PowerView Scene Controller works in conjunction with the PowerView Hub to quickly navigate and activate a personalized list of Scenes (created in the PowerView App) directly from the hand-held Pebble or wall-mounted Surface. PowerView Scene Controllers require a PowerView Hub.

Q: What do the Favourite buttons on the PowerView Scene Controller do?

A: The PowerView Scene Controller comes with two favourite buttons. Scenes can be assigned to each favourite button for one press activation.



TROUBLESHOOTING

FREQUENTLY ASKED QUESTIONS

POWERVERVIEW REPEATERS

Q: Will PowerView Repeater firmware update the same time PowerView Hub firmware does?

A: Repeater firmware will update if a firmware update is pushed from the PowerView server.

Q: What does the repeater look like while it is receiving a firmware update?

A: During an update, the repeater LED will flash blue no matter what the custom colour has been selected for the repeater. Once the firmware update has been completed the repeater will return to the users selected colour.

Q: Can Repeaters be used with PowerView Projects that are remote only?

A: Yes! Repeaters can be paired to a PowerView remote created PowerView Network. The Repeater's LED will be turned off by default but will still flash blue when repeating PowerView commands.

Q: How are PowerView Repeaters placed into the PowerView App?

A: PowerView Repeaters are placed into the PowerView App through the Discovery process. During the Discovery process, a Repeater will be paired to the PowerView Network. Once Discovered, Repeaters will appear in the Repeater Room in the Rooms tab.

Q: When Repeater Discovery occurs, do the Repeaters need to be in the intended final location within a home?

A: No. If you're Discovering Repeaters they do not have to be in the intended final location. However, the installer does need to ensure Repeaters are placed in a final location that ensures optimal PowerView Network coverage.

Q: Is there a limit to how many Repeaters can be used in a single PowerView project?

A: The most Repeaters that may be on a single PowerView project is 6 Repeaters.

Q: Once the repeaters are Discovered can they be named?

A: Yes, Repeaters can be named from the menu in the PowerView App under Accessories.

Q: When repeaters are discovered where do they appear in the PowerView App?

A: Repeaters will appear in the Repeater Room in the Rooms tab as well as the menu under Accessories.

Q: Where in the PowerView App may I customize the colour of the Repeater LED?

A: The Repeater LED can be customized from the Repeater Room in the Rooms tab.



TROUBLESHOOTING

SCENARIO 1

ISSUE	
Cause	Solution
Some PowerView® window treatments do not respond to commands from my PowerView remote (i.e., Pebble® Remote, Surface Remote or a combination).	
The window treatment(s) in question does not have power.	<ol style="list-style-type: none">1. CHECK all wires and cables for loose connections. VERIFY that correct power supply is being used and is plugged in. REPLACE batteries if needed2. PRESS and RELEASE the Programming button on the headrail to operate the window treatment.
The window treatment has not yet been joined to a Group(s) on the remote device.	<ol style="list-style-type: none">1. Group the window treatment(s) to the remote device as desired. <i>Joining a Shade to a Group</i>
The correct Group button is not selected.	<ol style="list-style-type: none">1. Make sure that the correct Group button is backlit when pressed, indicating that it has been selected.2. OPERATE a Group of shades as desired. <i>Product Operation: Groups 1-6</i>
The radio frequency signal emitted by the remote does not reach the window treatment(s).	<ol style="list-style-type: none">1. Move remote to a different location in the room and try again.2. ADD or MOVE a repeater closer to the window treatment(s) in question to extend the range of the remote(s).



TROUBLESHOOTING

SCENARIO 2

ISSUE	
<p>My PowerView® App can only Discover window treatments in one room, but not in any others. I have remotes for all the rooms, and they operate the window treatments in those rooms correctly.</p>	
Cause	Solution
<p>The window treatment(s) in question does not have power.</p>	<ol style="list-style-type: none"> CHECK all wires and cables for loose connections. VERIFY that correct power supply is being used and is plugged in. REPLACE batteries if needed PRESS and RELEASE the Programming button on the headrail to operate the shade.
<p>The radio frequency signal emitted by the Hub does not reach the window treatment(s).</p>	<ol style="list-style-type: none"> ADD or MOVE a repeater closer to the window treatment(s) in question and to the Hub to extend the range of the Hub. Test the repeater(s) to verify it is receiving a signal from the PowerView Hub. PRESS the "P" button on the back of the Hub for two seconds to send a test signal to the added or repositioned repeater(s). The green light on the repeater(s) should flash once when receiving/sending a signal. If the green light on the repeater does not flash when the Hub is emitting a signal, the Hub's signal still does not reach the repeater(s). RE-POSITION the repeater(s) and Hub (if possible), as necessary, or pair the repeater(s) to the same PowerView Shade Network as the Hub.
<p>There is more than one PowerView Shade Network in the home.</p>	<ol style="list-style-type: none"> VERIFY that all PowerView components are paired to the same PowerView Shade Network. <p>A. PLUG IN repeater(s) and the PRESS the Open button on the remote.</p> <p>If the green light in the repeater flashes, the remote and repeater(s) are on the same PowerView Shade Network.</p> <p>If the green light in the repeater does not flash, this indicates that the repeater is not paired to the same PowerView Shade Network as the remote.</p> REPEAT for all remotes. <p>B. PLUG IN repeater(s); OPEN the PowerView App; and TAP Discover Shades in the Shades tab screen.</p> <p>If the green light in the repeater flashes, the Hub and repeater(s) are on the same PowerView Shade Network.</p> <p>If the green light in the repeater does not flash, it indicates that the repeater is not paired to the same PowerView Shade Network as the Hub.</p> Clear the programming on each of the window treatment(s) in question. PRESS and HOLD the programming button on the headrail for 12 seconds. The shade will jog once at 6 seconds then again at 12 seconds. PAIR any remotes not currently networked with the Hub to the Hub. <i>Pairing a Remote to a Hub</i> GROUP the window treatments in question to the newly networked remotes, as desired. <i>Joining a Shade to a Group</i> OPEN the App. DISCOVER all the shade(s) in the App. <i>Discover Shades</i>



TROUBLESHOOTING

SCENARIO 3

ISSUE	
<p>I have a remote and a PowerView® Hub. I was able to Discover my PowerView window treatments using the App, but now I cannot operate any window treatments from the App.</p>	
Cause	Solution
<p>The mobile device running the PowerView App is connected to the wrong home Wi-Fi network.</p>	<ol style="list-style-type: none"> CLOSE OUT of the PowerView App. CHECK the Hub's and Wi-Fi router's connections. Make sure both have power and are properly connected to one another. ACCESS the mobile device's settings. Ensure that the mobile device is connected to the same home Wi-Fi network as the Hub. In the App, CONNECT to the correct Hub.
<p>The window treatment(s) in question does not have power.</p>	<ol style="list-style-type: none"> RECONNECT power cords, change batteries, etc. as necessary. CHECK all wires and cables for loose connections. VERIFY that correct power supply is being used and is plugged in. REPLACE batteries if needed. PRESS and RELEASE the Programming button on the headrail to operate the shade, running it up or down.
<p>There is more than one PowerView Shade Network in the home.</p>	<ol style="list-style-type: none"> VERIFY that all PowerView components are paired to the same PowerView Shade Network. <ol style="list-style-type: none"> PLUG IN repeater(s) and the PRESS the Open button on the remote. If the green light in the repeater flashes, the remote and repeater(s) are on the same PowerView Shade Network. If the green light in the repeater does not flash, this indicates that the repeater is not paired to the same PowerView Shade Network as the remote. REPEAT for all remotes. <ol style="list-style-type: none"> PLUG IN repeater(s); OPEN the PowerView App; and TAP Discover Shades in the Shades tab screen. If the green light in the repeater flashes, the Hub and repeater(s) are on the same PowerView Shade Network. If the green light in the repeater does not flash, this indicates that the repeater is not paired to the same PowerView Shade Network as the Hub. Clear the programming on each of the window treatment(s) in question. PRESS and HOLD the Programming button on the headrail for 12 seconds. The shade will jog once at six seconds then again at 12 seconds. PAIR any remotes not currently networked with the Hub to the Hub. Pairing a Remote to a Hub GROUP the window treatments in question to the newly networked remotes, as desired. Joining a Shade to a Group OPEN the App. DISCOVER all the shade(s) in the App. Discover Shades



TROUBLESHOOTING

SCENARIO 3 CONTINUED

ISSUE continued...	
I have a remote and a PowerView® Hub. I was able to Discover my PowerView window treatments using the App, but now I cannot operate any window treatments from the App.	
Cause	Solution
A 12-second reset has been performed after window treatment(s) were Discovered in the PowerView App, erasing all programming information at the window treatment.	<ol style="list-style-type: none">1. TAP Delete Shade in the Shade Edit screen in the PowerView App to delete the window treatment(s) in question.2. TAP Discover Shades to Discover the window treatment(s) in the Shades tab. <i>Discover Shades</i>3. GROUP the window treatment(s) in question to the newly networked remotes, as desired. <i>Joining a Shade to a Group</i>



TROUBLESHOOTING

SCENARIO 4

ISSUE	
The batteries in my showroom Pebble™ Remote(s) don't last long.	
Cause	Solution
The remote is not frequently used but it is placed or located in a location where it is subject to frequent movement (e.g., a frequently accessed drawer).	<ol style="list-style-type: none"> 1. Preserve battery life by keeping the remote in a location where it will not be moved inadvertently. This will prevent the auto-wake feature from turning the backlights on and draining the batteries.
The remote is handled frequently, daily.	<ol style="list-style-type: none"> 1. Preserve battery life by disabling the auto-wake function by PRESSING and HOLDING the Group 6 button on the remote for approximately six seconds. The Group numbers (1-6) will blink once to indicate the auto-wake function has been disabled. <p>*To turn the auto-wake function back on:</p> <ol style="list-style-type: none"> 1. PRESS and HOLD the Group 6 button for approximately six seconds. The Group numbers (1-6) blink twice to indicate the accelerometer has been turned back on.
The batteries are not dead, but remote is in "Learning Mode".	<p>In Learning Mode, only the Group buttons blink when the Open or Close button is pressed.</p> <ol style="list-style-type: none"> 1. To get out of Learning Mode, PAIR remote to another remote or Hub or PRESS the programming button on the remote (behind the battery cover.)



TROUBLESHOOTING

SCENARIO 5

ISSUE	
PowerView® window treatment does not correctly respond to Scenes in the App. Or, a PowerView window treatment responds to Scenes to which it does not belong in the App.	
Cause	Solution
A manual 12-second reset was performed at the headrail; or, the window treatment was previously deleted from the App and then re-Discovered. Room and Scene settings, however, did not purge. Instead, this information continued to be retained in the headrail.	<ol style="list-style-type: none">1. OPEN the specific Detail page for the window treatment(s) in question.2. SELECT the “Advanced” option.3. SELECT “Sync Shade Memory”. This command will remove the window treatment from the Room(s) and Scene(s) to which it is associated, and sync with the saved Room and Scene settings for the specific window treatment.

SCENARIO 6

ISSUE	
There is slack in the cords that operate a Duette® Top-Down/Bottom-Up or Day/Night Honeycomb Shade when the middle rail is fully lowered.	
Cause	Solution
There is excess operating cord not taken up by the spool in the shade head rail.	Adjust the shade’s middle rail bottom position until the excess operating cord is taken up by the spool.

