

Te Rā Folding Arm Awnings Installation Manual



Luxaflex[®]
WINDOW FASHIONS

FEATURES & BENEFITS

FEATURES

5 Awning Options

Wind Tested

3 Standard Hardware Colour Options

3 Year Warranty

Flexible Roof Brackets

Crank Handle

Somfy Automation

Roller Valance

Pitch Control

Telescopic Arm

Rain Hood

BENEFITS

Ensuring that there is one option that will suit nearly any space

Made to withstand the different wind elements in and around New Zealand to offer longevity

Sleek sophisticated finish to match with the home look and feel

Peace of mind

Option to change angle for awning to fit in most installation surfaces

Easy operation to project awning as well as control other optional areas of awning

Option to automate awning for faster projection and retraction. As the motor options are all Somfy motors, essentially provides the opportunity to match with other Somfy automated products in and around the home as well as Somfy Connexoon.

Roller Valance is perfect to reduce those areas prone to sun glare more

Allowing the option to vary the pitch of the awning from -5° to -40° to assist with superior shade control

Stabilises awning when wind conditions increase offering added strength to awning

Improve fabric protection on all models from the elements assisting in extending the life of the awning

OVERVIEW

Swedish designed awnings that will outperform anything you've seen before, whatever the weather.

Weathermaster's worldwide search for the best solutions for New Zealand conditions brings you a range of innovative heavy-duty awnings that deliver unparalleled functionality. With five styles to choose from, spanning widths up to seven metres and offering a massive four-metre depth, they are perfect for decks, balconies, shops, restaurants and more.

The Te Ra folding-arm range of awnings has been engineered to meet stringent quality standards, whether you choose the Viento style with its stylishly clean fascia or the unique Eclipse style for maximum projection from the narrowest of awnings.

STABILITY & STRENGTH

The Dyneema-tape connection used over the knee and arm brackets on Te Ra awnings is 15 times stronger than steel and 40% stronger than aramids on a weight-for-weight basis. Plus, it's UV, chemical and moisture resistant to provide a durable and yet lightweight material that further improves the stability and tension provided by the awning's heavy-duty springs.

AWNING COVERAGE

The robust retractable arms on a Te Ra awning allow for maximum spans of seven metres in width and are capable of projecting up to four metres out from the building.

This very generous coverage requires no posts or other structures for support thereby maximising your freedom to enjoy the cover provided and ensuring that the awning presents a clearer visual appearance.

WIND STRENGTH

The entire range benefits from thorough wind performance testing to meet Designpean 13651 wind classification standards. This ensure that the awning is protected when the wind starts to build up.

Note: It is recommended that all awnings are retracted when wind starts to pick up. Awnings must be mounted with the right amount of installation brackets and with suitable fasteners to match the below wind classes.

Wind Class	Wind Strength	Wind Speed (km/h)
1	4	20 – 28km/h
2	5	29 – 38km/h
3	6	39 – 49km/h

Te Ra Origin, Te Ra Euro, Te Ra Eclipse and Te Ra Beam

P/W	4m	5m	6m	7m
2.5m				
3.0m				
3.5m				
4.0m	N/A		N/A	N/A

Te Ra Viento

P/W	4m	5m	6m	7m
2.5m				
3.0m				
3.5m				
4.0m	N/A	N/A	N/A	N/A

Te Ra Euro, Te Ra Eclipse and Te Ra Beam with Roller Valance

P/W	4m	5m	6m	7m
2.5m				
3.0m				
3.5m			N/A	N/A
4.0m	N/A	N/A	N/A	N/A

Hardware Colour Options

All Te Ra awnings hardware comes in three standard colours: Gravel, Silver and White. This enables different components and accessories to be used across the entire range, further enhancing your ability to choose the awning solution that's right for you.



Gravel



Silver

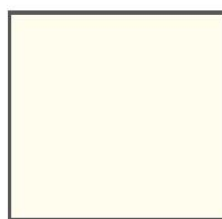

White

OPERATING OPTIONS

TE RA ORIGIN



A proven design that utilises a simple square bar for easy installation in a wide variety of locations. Features include the latest in modular design and a range of accessories to customise your awning and enhance your enjoyment in a range of outdoor situations.

DIMENSIONS

Width:

Min 2.074m

Max 7.00m

Projection:

Min 1.6m

Max 4.0m

TE RA ECLIPSE



This is Te Ra's solution for installations that necessitate a narrow awning without compromising on weather protection. The Eclipse utilises an ingenious cross-over system for the arms that projects the awning out further than would otherwise be possible, and dramatically increases the weather projection that's available.

DIMENSIONS

Width:

Min 1.332m

Max 4.6m

Projection:

Min 1.6m

Max 4.0m

TE RA EURO



The durable and very good looking Te Ra Euro folding arm awning will add style and sophistication to any outdoor setting. With Designpean designer detailing such as the special pressure die-cast end brackets and Te Ra 's renowned quality proving to be a very attractive combination.

DIMENSIONS

Width:

Min 2.137m

Max 7.00m

Projection:

Min 1.6m

Max 4.0m

TE RA BEAM



Lack of clearance above a doorway is no barrier to the Te Ra Beam. This awning extends horizontally from the building before utilising a change of pitch at the elbow joint to slope down for good shading performance.

DIMENSIONS

Width:

Min 2.72m

Max 7.00m

Projection:

Min 1.6m

Max 4.0m

TE RA VIENTO



By including a compact semi-enclosure feature Te Ra Viento has created an awning system that protects the fabric from the elements when not in use. In addition to increasing the longevity of the fabric this system also hides the fabric roller tube from view, presenting a streamlined finish to the awning.

DIMENSIONS

Width:

Min 2.005m

Max 7.00m

Projection:

Min 1.6m

Max 3.5m

OPTIONAL EXTRAS

ROLLER VALANCE



Add an additional screening fabric to your awning, which is easily operated by a crank handle and stores away when not in use.

Available with Te Ra Eclipse, Euro and Beam awnings

PITCH CONTROL



An optional adjustment function that allows you to vary the pitch of the awning from -5° to -40° to better control shade

Available with Te Ra Origin, Euro, Beam and Eclipse awnings

TELESCOPIC ARM



A telescopic pole can be used in windy conditions to stabilise the front bar, increasing your awning's wind resistance and extending its life. These poles are collapsible for easy storage

Available with Te Ra Origin, Euro, Eclipse and Beam awnings

RAIN HOOD



An optional rain hood is a stylish accessory that will provide improved fabric protection from the elements and extend the life of your awning's fabric.

Available with Te Ra Origin, Euro, Eclipse and Beam awnings

CONTROL OPTIONS

Te Ra Awnings are easy to operate with one of two options – manual crank handle or motorisation using Somfy automation.

CRANK HANDLE

A manual crank control will easily project and retract awnings up to 7 meters, however larger awnings will benefit from motorised operation due to the weight of the awning. Crank handles are available in 4 different sizes as well as colours to match the hardware choice of each awning.



AUTOMATION

Operate your awning with the touch of a button using either a hard-wired or remote control. For complete automation consider the convenience of incorporating sun and wind sensors. Wind sensors assist with automatic retraction of the awning in the event of high winds adding extra protection if the awning may be out while you're not home. As an added advantage, all Te Ra Automated Awnings use a Somfy controlled motor which can be linked up to other Somfy Automated devices throughout your home e.g. Rollershades



INSTALLING THE AWNING

Place the awning in front of the installation site and measure out the height for the external brackets.

These must sit as close to the arm's attachment on the supporting tube as possible. Mark out and drill the holes for these brackets.

Mount the brackets using the appropriate plugs and screws.

Stretch a piece of string between the outer brackets, mark and drill the holes for the other brackets.

Keep in mind to place the brackets at the correct height so that the awning has a ground clearance at the front edge of 2.0 - 2.2 metres

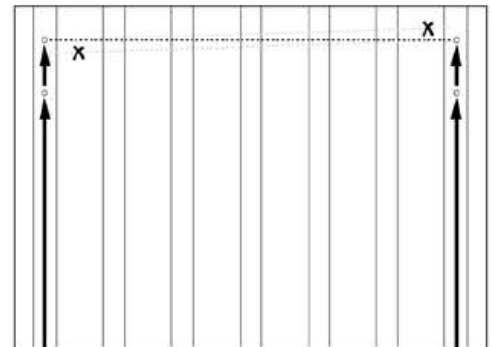

Place the awning in the brackets with the supporting profiles. Lock the supporting profile using the bracket bolt.

If face-fixed to masonry, there must be at least seven courses of bricks above the mounting position.

The spreader plate is used with support tube awnings to spread the load over three courses of bricks. A minimum of four bricks below the spreader plate is recommended.

REVERSE RAFTER BRACKETS

Rafter bracket sets may be used to suspend the awning from rafters. Tiles must be pushed back for access. The rafter bracket is then bolted to the rafter so that the mounting surface sits on the eaves lining. The awning mounting bracket has a plate that is adjust able to suit the angle of the rafter from 5° - 45°. The universal bracket can then be installed to the rafter bracket.

Alternatively, the fascia bracket can be used to gain even more height and install an awning on the outside of the gutter. See sketch. (Use with any wall bracket).

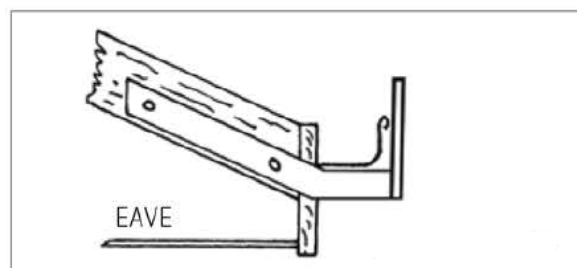
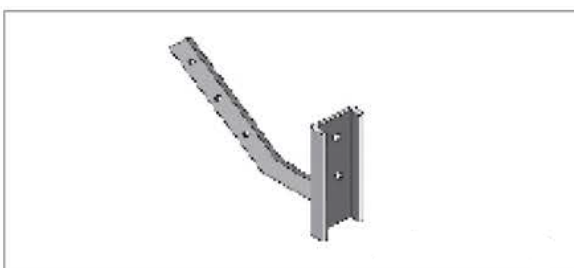

INSTALLING THE RAIN HOOD

- A. Mount the Hood brackets to the roof using a bracket at each outer end of the roof.

The remaining brackets are mounted at a max 1.5 metre distance from each other and distributed evenly over the awning Hood.

Screw on the nuts loosely so that the Hood can be adjusted when it is in place.

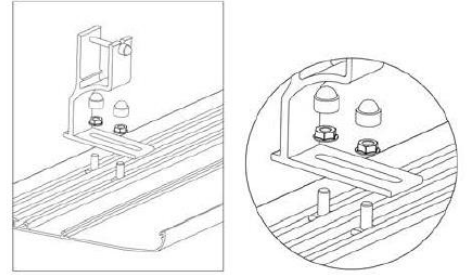

- B. Mount the roof to the square tube and tighten the screws.

Then move the Hood bracket downwards so that the screw ends up on the underside of the square tube.

Now lock the Hood bracket to the square tube using the screw.

Adjust the Hood at the side and against the wall, then tighten the screws.

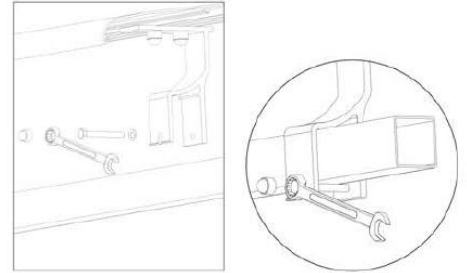

- C. Screw the ends to the Hood screw pockets once the Hood has been mounted.

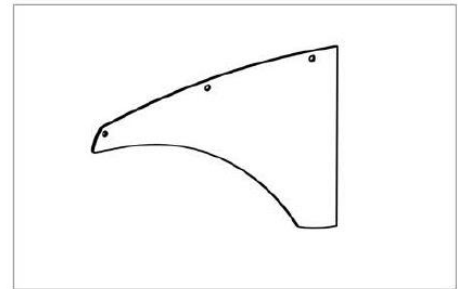

BOLTS REQUIRES FOR MOUNTING

Recommended bolts required for standard installation of brackets

- Standard Wall/Universal Bracket 2 12mm x 75mm coach bolts & flat washers
2 12 x 75mm dyna-bolts
- Rafter Bracket Set - Origin 2 10mm x 75mm Hex bolts (fully threaded),
nuts & spring washers – brick fix
2 10mm x 40mm Hex bolts (fully threaded),
nuts & spring washers – wood fix
- Fascia Bracket - Origin 2 10mm x 75mm Hex bolts (fully threaded),
nuts & spring washers

ALL FABRICS

Fabric requirement at projection arm projection + 250mm excluding valance.

VIENTO - POSITION OF FABRIC ONTO ROLLER TUBE

The fabric should be positioned 40mm from the edge of bushing on the roller side, to come straight into the cassette.

(NOT AVAILABLE ON VIENTO)

The hood brackets should be assembled 600mm from the end bracket. Max distance between hood brackets 1500mm.

SPECIAL INSTRUCTIONS FOR AWNING WITH THREE FOLDING ARMS

The folding arm in the middle should not have any spring tension in the connection between the folding arm and arm bracket. Remove the spring tension in the centre arm at the arm connection at the square tube. Remove the pin that holds the Dyneema tape with a small flat headed screwdriver.

FABRICATION GUIDELINES

Origin, Euro, Eclipse, Beam & Viento
No. of installation bracket per width and
projection

Projection	Width (m)	≤4	≤5	≤6	≤7
	1.6m	2	2	4	6
2.0m	2	2	4	6	
2.5m	2	4	4	6	
3.0m	4	4	4	6	
3.5m	4	4	5	6	
4.0m	4	5	5		

The awning width is defined as the total horizontal length of the awning excluding hood. The arm brackets should be assembled 1/6 of the total width, from the end bracket, when the combination of projection and width allows.

ADJUSTMENT OF PROJECTION ANGLE/PITCH

(ALL TE RA AWNINGS EXCEPT VIENTO MODEL)

The awnings projection angle is adjusted with the stop screw and the screw located in the arm holder.

Adjusting the pitch on any awning should be at minimum, a two man job for safety reasons. It's important that you adjust one arm at a time.

1. Crank out/roll out the awning fully
2. Have one person take the weight of the awning
One arm; at the arm end closest to the front bar
Second arm; on the front bar itself. This ensure the stop screw (2) is not stressed
(NOTE! There may be a bang when the arm is lifted, and the conical washer loosens.)
3. Loosen the stop screw (2) one to two turns
4. Loosen the arm bracket screw (1).
The recommended minimum pitch is 10 degrees.



Do not loosen the arm bracket screw more than 3 complete turns.

5. With the person holding the weight of the awning, adjust the pitch on the awning up or down as required
6. Hold the awning in the new location and tighten the arm bracket screws (1)
7. Tighten the stop screw (2) in the arm bracket. The other arms are adjusted in the same way.
A ground clearance of 2.0 - 2.2 metres at the front edge of the awning is recommended.
8. Complete the same process for the second arm.
9. Project and retract the awning a few times to ensure levelling is correct and awning is functioning correctly.
(NOTE! Always ensure that the front bar is levelled before retracting awning in)

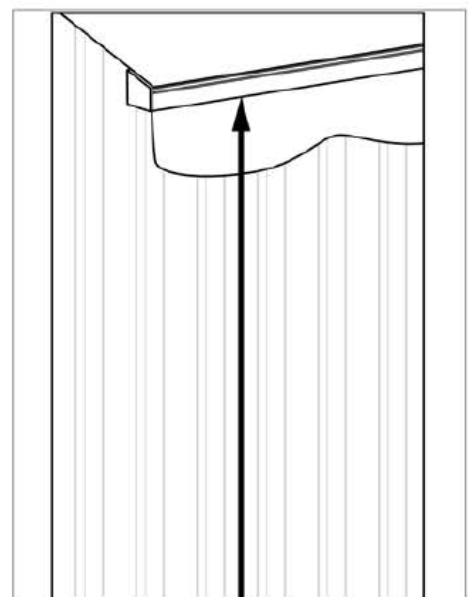
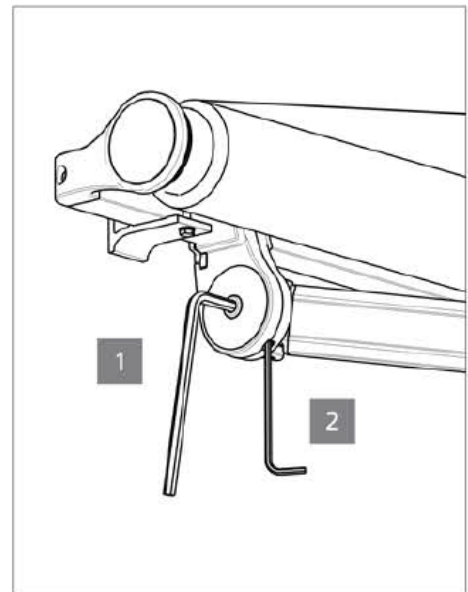

ADJUSTMENT OF PROJECTION ANGLE/PITCH

TE RA VIENTO MODEL

The awnings projection angle is adjusted with the stop screw and the screw located in the arm holder.

Adjusting the pitch on any awning should be at minimum, a two man job for safety reasons. It's important that you adjust one arm at a time.

1. Crank out/roll out the awning fully
2. Have one person take the weight of the awning
One arm; at the arm end closest to the front bar
Second arm; on the front bar itself. This ensure the stop screw (2) is not stressed
(NOTE! There may be a bang when the arm is lifted, and the conical washer loosens.)
3. Loosen the stop screw (2) one to two turns
4. Loosen the arm bracket screw (1).
The recommended minimum pitch is 10 degrees.

! Do not loosen the arm bracket screw more than 3 complete turns.

5. With the person holding the weight of the awning, adjust pitch on the awning up or down as required
6. Hold the awning in the new location and tighten the arm bracket screws (1)
7. Tighten the stop screw (2) in the arm bracket. The other arms are adjusted in the same way.
A ground clearance of 2.0 - 2.2 metres at the front edge of the awning is recommended.
8. Complete the same process for the second arm.
9. Project and retract the awning a few times to ensure levelling is correct and awning is functioning correctly.
(NOTE! Always ensure that the front bar is levelled before retracting awning in)

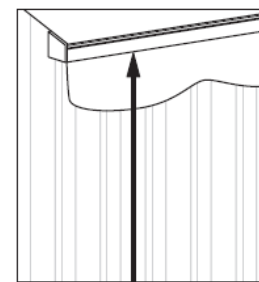
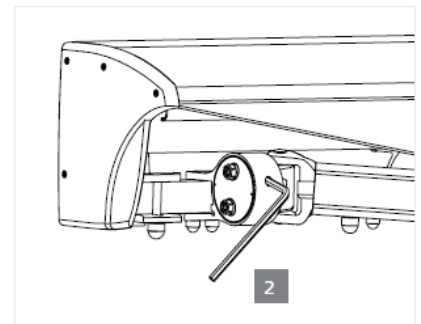
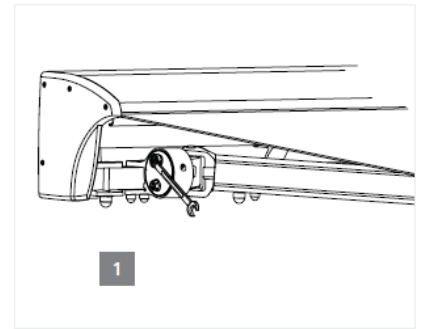

ADJUSTMENT OF FRONT PROFILE

TE RA VIENTO MODEL

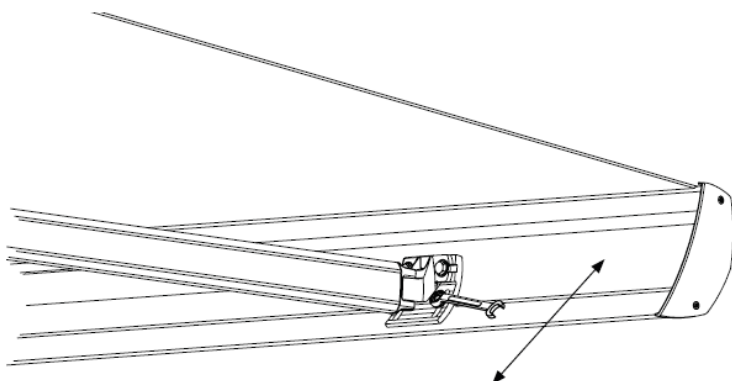

! Adjusting the front profile should always be a two man job for safety reasons.

To receive the correct position of the front profile, the front profile is adjusted as follows:

1. Roll out the awning until the fabric slackens. Mark position of bracket to ensure you maintain the bracket position sidewise
2. Unscrew the two bottom nuts on the adjustment bracket, holding the front profile.
(NOTE! Do not remove the nuts completely)
3. Move the front profile up or down until receiving the correct position when rolled in.
4. Fasten the screws.

OPERATION & MAINTENANCE INSTRUCTIONS FOR AWNINGS

CLEANING

The frame and the fabric are subjected to dirt and pollution and should be cleaned at least once a year to retain their high finish. This is particularly important in more exposed installations, e.g. environments near the sea. Use a soft cloth, tepid water and a mild cleaner. Do not use a high-pressure washer as it can damage the awning fabric and any electrical equipment, etc. For a detailed description of cleaning the fabric, please refer to its usage instructions.

REMOVAL OF THE AWNINGS VALANCE

The valance is the most exposed part of the awning. To increase the valance's lifespan, it can be stored indoors during the winter months. First loosen the front profile's left or right end cover. Then loosen the valance's fabric lock. Move the valance to the side so that it slides out from the front profile. Put back the end cover and store the valance indoors.

CHANGING THE AWNING FABRIC

Before changing the awning fabric, it is recommended to contact the company from which the awning was purchased to arrange an inspection of the frame. This company can provide more information about changing the fabric and also provide advice in case some other component may need to be replaced in order for the awning to maintain its finish and function.

WARNING - ALWAYS ALLOW A PROFESSIONAL TO ADJUST THE FOLDING ARMS

An awning has very powerful springs inside the arm's aluminium profiles. If the arm is loosened without first being secured, it can cause serious personal injury and in the worst-case death. The arms must therefore always be adjusted by a professional.

WARNING - ALWAYS ALLOW A PROFESSIONAL TO LOOSEN THE AWNINGS END COVER

The awning's end cover may need to be loosened when changing gears, the motor or the fabric. If the awning's end cover is loosened without all of the awning's arms being secure, the arms can cause serious personal injury and in the worst-case death. The awning's end covers must therefore always be loosened by a professional.

WARNING - ROLLING OUT THE AWNING

When washing windows, painting the facade, or carrying out maintenance or repair of the awning, there are risks, e.g. the ladder tipping over if the awning is rolled out when the work is being carried out. You should therefore keep the awning rolled up when work is being carried out near the sun protection. The automatic mechanisms on motorised awnings must be shut off in order to avoid unintentional operation.

Also make sure that the awning cannot make portable infrared or bottled gas heaters tip over or come into contact with other objects that could damage the awning or cause other injuries.

FABRICATION GUIDELINES FOR TE RA AWNINGS

Origin, Euro, Beam, Eclipse & Viento

Folding arm, installation bracket and centre support per roller tube and awning width

No. of Installation Brackets	Projection	Width (m)	≤4	≤5	≤6	≤7
		1.6m	2	2	4	6
2.0m	2	2	4	6		
2.5m	2	4	4	6		
3.5m	4	4	4	6		
3.5m	4	4	5	6		
4.0m	4	5	5			

The awning width is defined as the total horizontal length of the awning excluding hood. The arm brackets should be assembled 1/6 of the total width, from the end bracket, when the combination of projection and width allows.

POSITION OF INSTALLATION BRACKET

The installation bracket should be positioned as close to the arm bracket as possible.

FOLDING ARM ALLOCATION CHARTS

TE RA ORIGIN & EURO

Note: Not able to be under 2500mm widths

Up to	1600	2000	2500	3000	3500	4000	4500	4600	5000	5500	6000	6500	7000
1600			2	2	2	2	2	2	2	2	2	3	3
2000				2	2	2	2	2	2	2	2	3	3
2500					2	2	2	2	2	2	2	3	3
3000						2	2	2	2	2	2	3	3
3500							2	2	2	2	2	2	3
4000								2	2	2	2	2	2

TE RA BEAM

Note: Not able to be under 2500mm widths

Up to	1600	2000	2500	3000	3500	4000	4500	5000	5500	6000	6500	7000
1600			2	2	2	2	2	2	2	2	3	3
2000				2	2	2	2	2	2	2	3	3
2500					2	2	2	2	2	2	3	3
3000						2	2	2	2	2	3	3
3500							2	2	2	2	2	2
4000								2	2	2	2	2

TE RA ECLIPSE

Up to	1600	2000	2500	3000	3500	4000	4500	4600
1600	2	2	2	2	2	2	2	2
2000		2	2	2	2	2	2	2
2500		2	2	2	2	2	2	2
3000			2	2	2	2	2	2
3500			2	2	2	2	2	2
4000				2	2	2	2	2

TE RA VIENTO

Up to	1600	2000	2500	3000	3500	4000	4500	5000	5500	6000	6500	7000
1600			2	2	2	2	2	2	2	2	3	3
2000			2	2	2	2	2	2	2	2	3	3
2500				2	2	2	2	2	2	2	3	3
3000					2	2	2	2	2	2	3	3
3500						2	2	2	2	2	3	3
4000	2	2	2	2	2	2		2	2	2		

INSTALLATION BRACKETS DIMENSIONS

TE RA ORIGIN BRACKET

Used for Face Fix or Top Fix installation

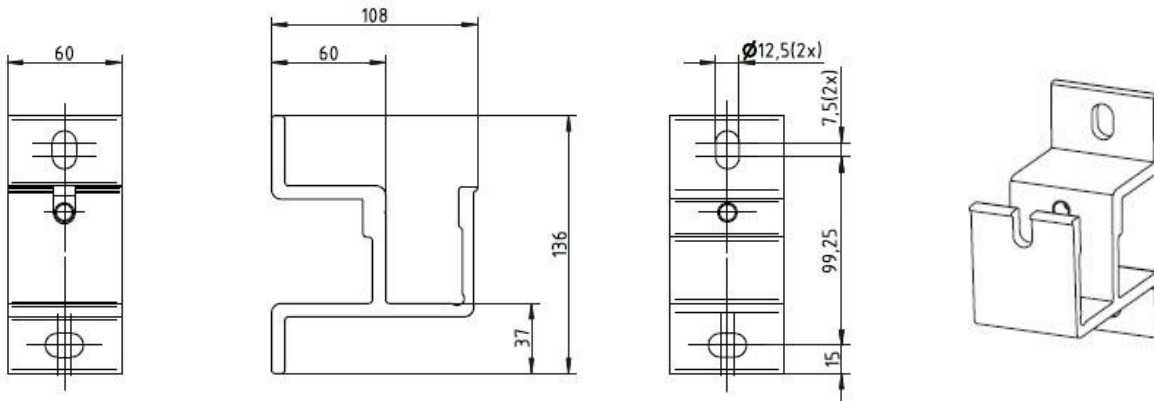

TE RA EURO, ECLIPSE & BEAM WALL BRACKET

Used for Face Fix installation

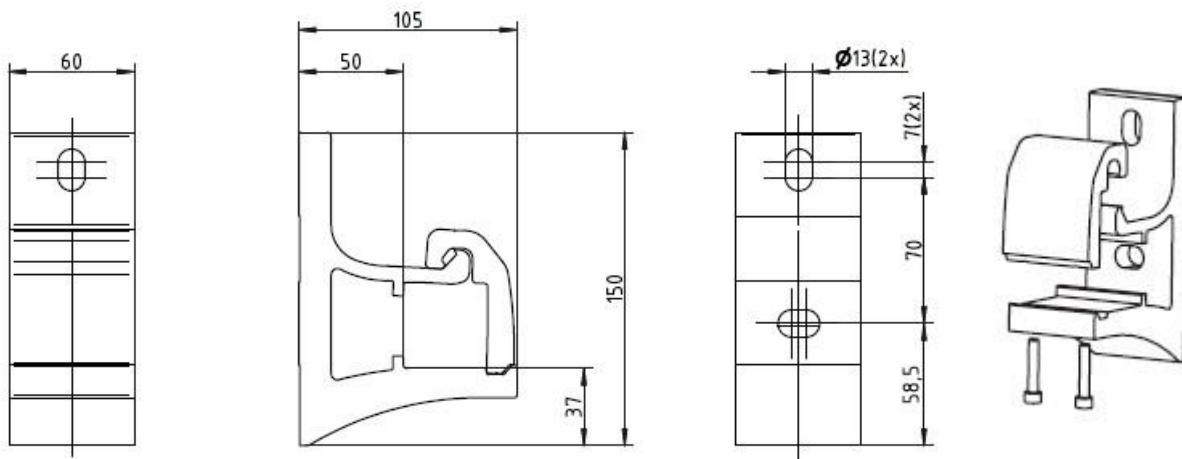

TE RA EURO, ECLIPSE & BEAM ROOF BRACKET

Added to Face Fix bracket for Top Fix installation

Used for installations required for installation of between 5° - 45°

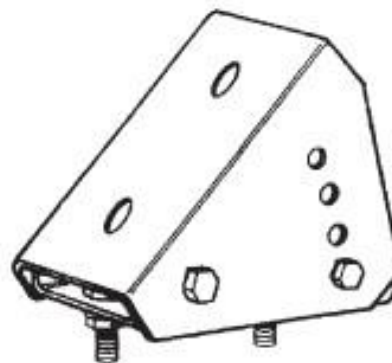
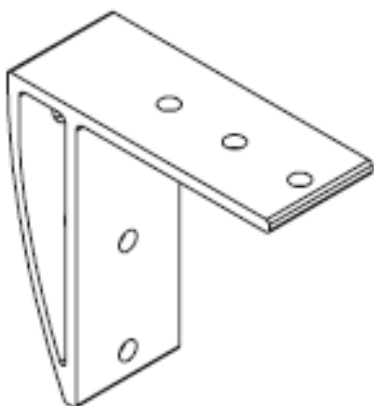

TE RA VIENTO WALL BRACKET

Used for Face Fix installation

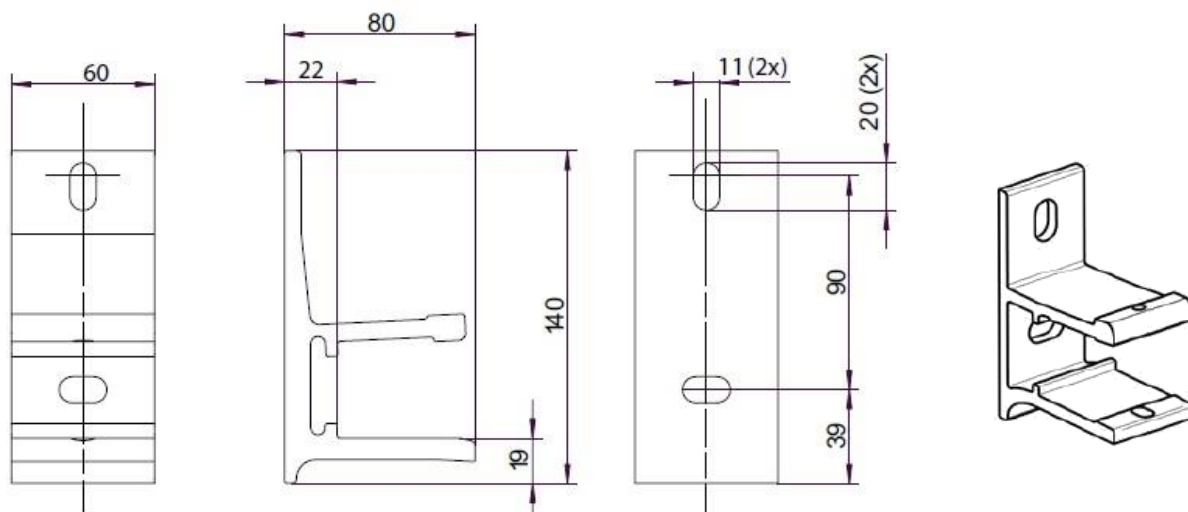

TE RA VIENTO BRACKET

Used for Top Fix installation

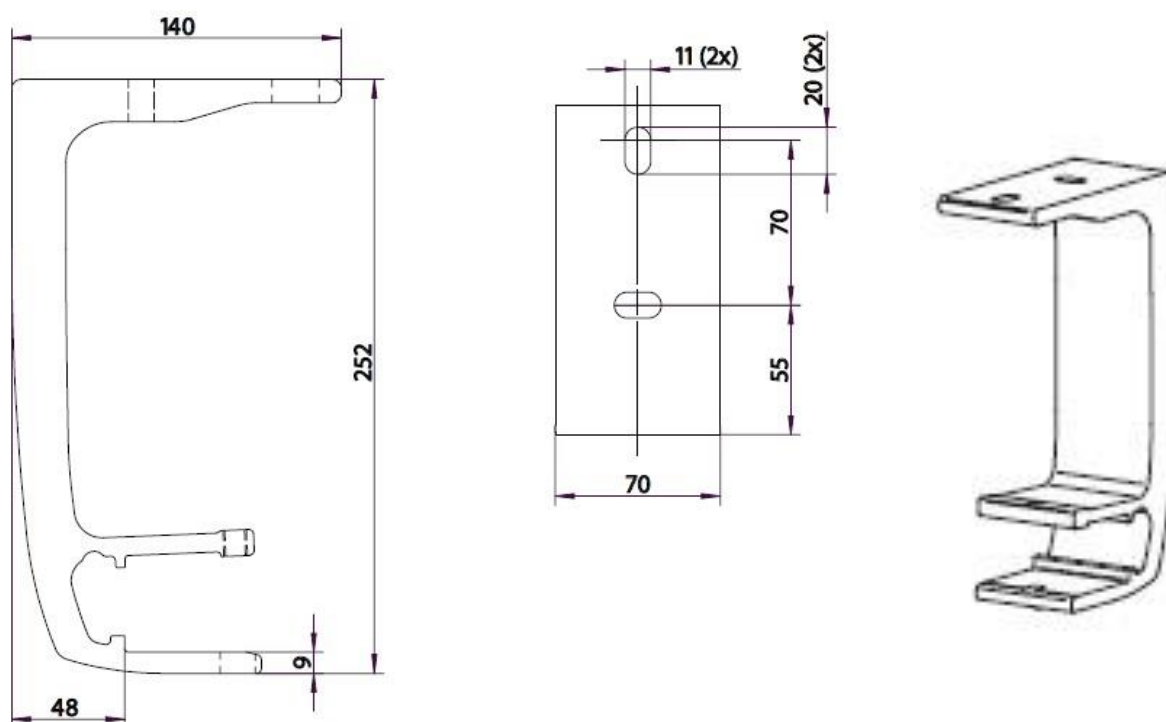

UNDER EAVE EXTENSIONS BRACKET

The Under-Eave Extension Bracket enables a Folding Arm Awning to be positioned in front of the spouting to ensure adequate headroom is achieved. These Brackets are Manufactured from 5mm thick Steel with a Powder Coat Finish.

Standard Colour Options:

White
Silver
Gravel

Hole Position from Front Edge (8mm Hole)

First Hole 210mm
Second Hole 410mm
Third Hole 630mm

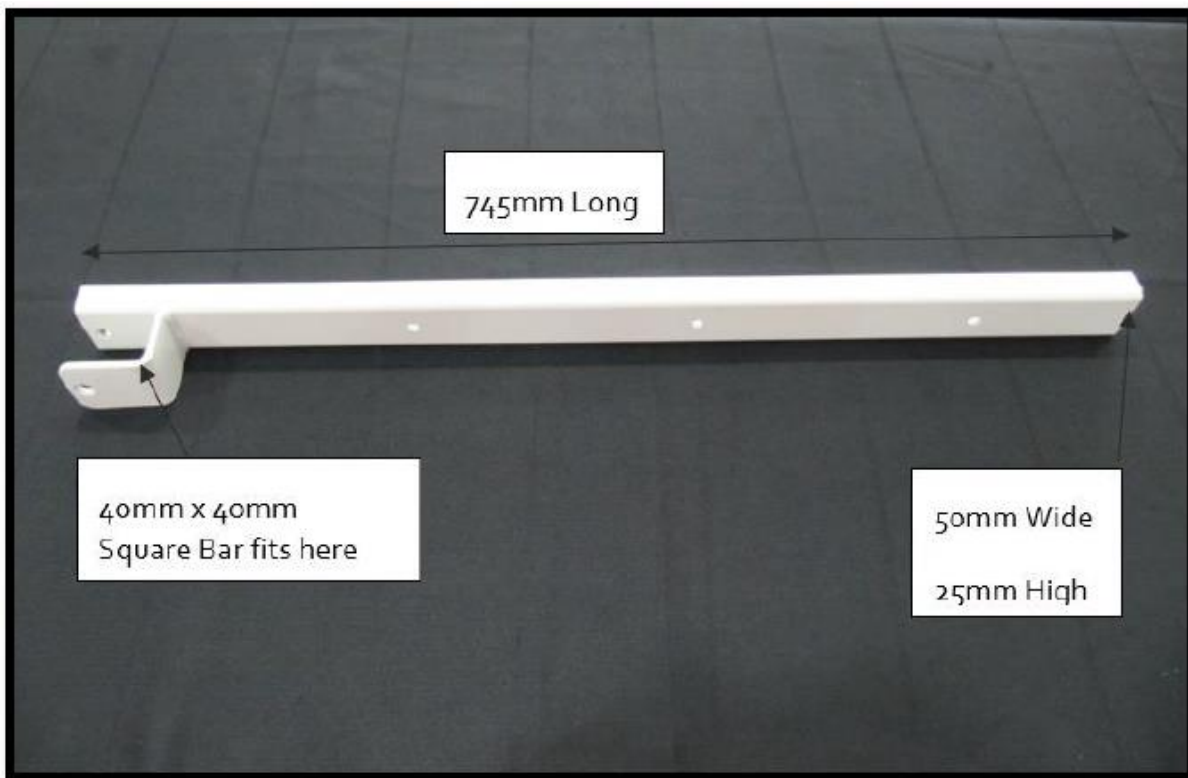

FABRICATION

WEIGHT (IN KILOGRAMS) PER WIDTH & PROJECTION

Euro and Beam Weight (kilogram) per width and projection

Width (m)	3.0	3.5	4.0	4.5	5.0	5.5	6.0	6.5	7.0	
Projection	1.6m	27.5	35.5	45.0	47.5	51.5	53.5	57.0	67.5	71.5
	2.0m	29.5	37.5	46.5	49.0	53.0	55.5	59.0	69.5	73.0
	2.5m		40.0	48.5	51.0	54.5	57.5	61.5	72.5	75.5
	3.0m			50.5	52.5	56.5	59.5	63.0	75.0	78.0
	3.5m				54.5	58.0	62.0	65.5	77.5	80.5
	4.0m				60.5	64.0	67.5	70.5		

Hood	+	3kg/m (incl bracket and side covers)
Classic End Brackets	-	0.6kg/awning
Rise	+	1kg/m
Pitch Control	+	0.9kg/arm
Roller Tube 85mm	+	0.7kg/m
Roller Valance Front	+	4.7kg/m
Gear	-	2kg/awning

Viento Weight (kilogram) per width and projection

Width (m)	3.0	3.5	4.0	4.5	5.0	5.5	6.0	6.5	7.0	
Projection	1.6m	42.5	53.0	69.5	69.5	76.0	80.5	86.5	99.0	706.0
	2.0m	44.5	55.0	66.0	71.0	77.5	82.5	88.5	101.0	107.5
	2.5m		57.5	68.0	73.0	79.0	84.5	91.0	104.0	110.0
	3.0m			70.0	74.5	81.0	86.5	92.5	106.5	112.0
	3.5m				77.0	82.5	89.0	95.0	109.0	115.0
	4.0m				82.5	88.5	94.5	100.0		

Roller Tube 85mm	+	0.7kg/m
------------------	---	---------

INSTALLATION VIEWS - TE RA ORIGIN

Origin Awning

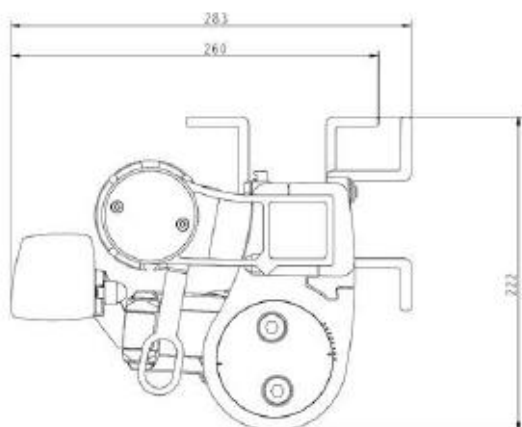

Origin with Hood

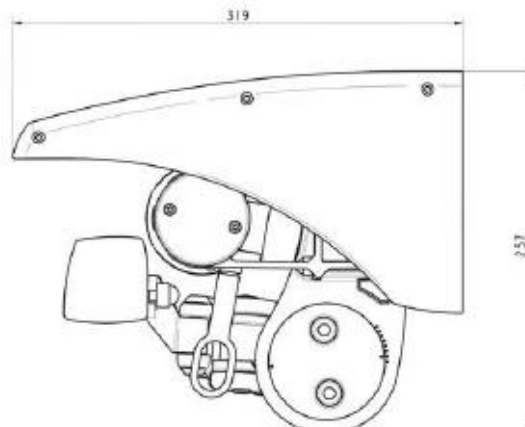

Origin with Pitch Control

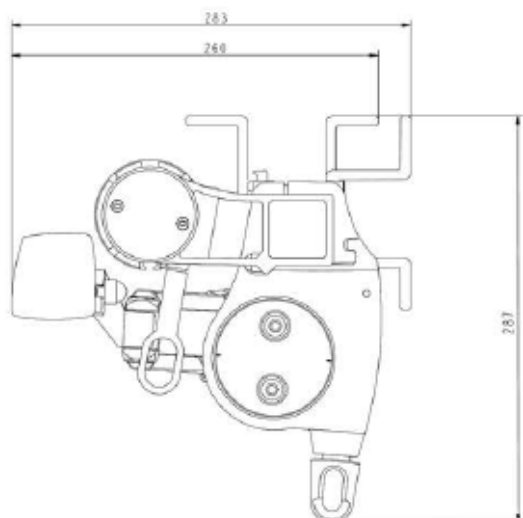

Origin with Pitch Control & Hood

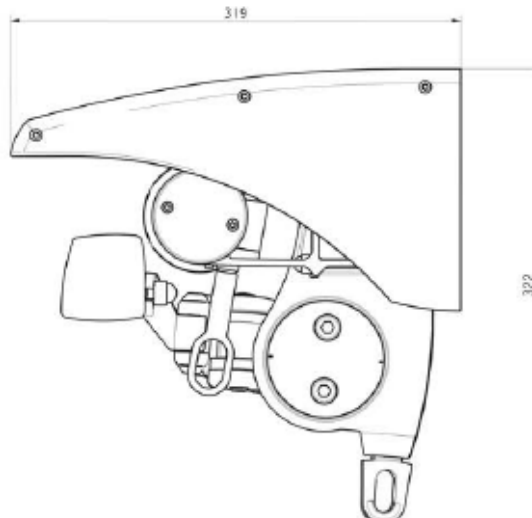

INSTALLATION VIEWS - TE RA EURO

Euro Awning

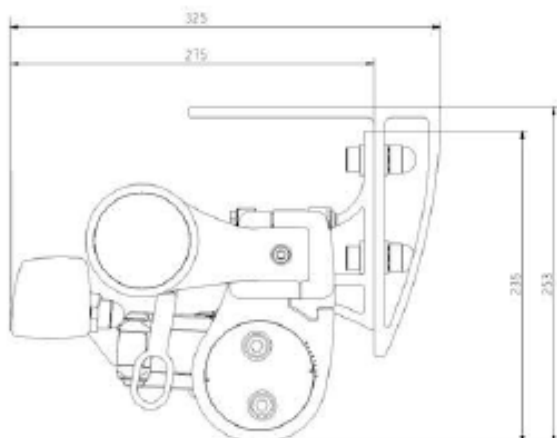

Euro with Hood

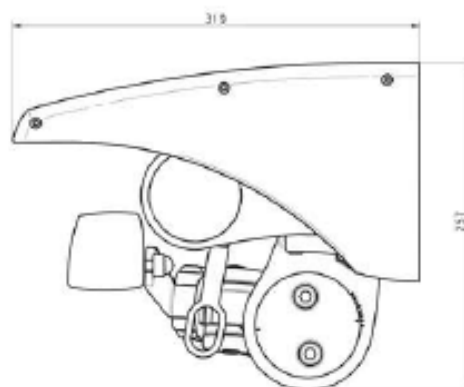

Euro with Pitch Control

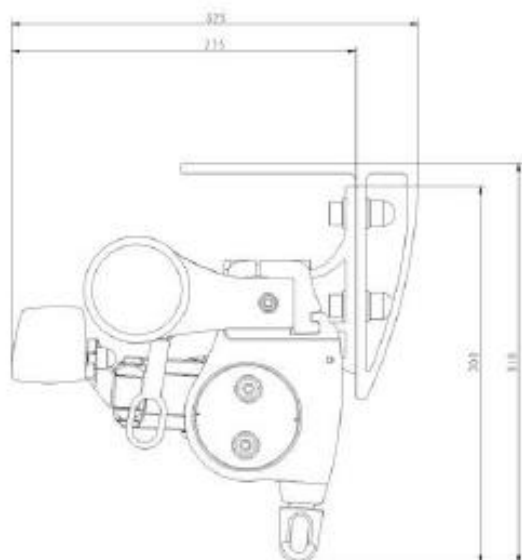

Euro with Pitch Control & Hood

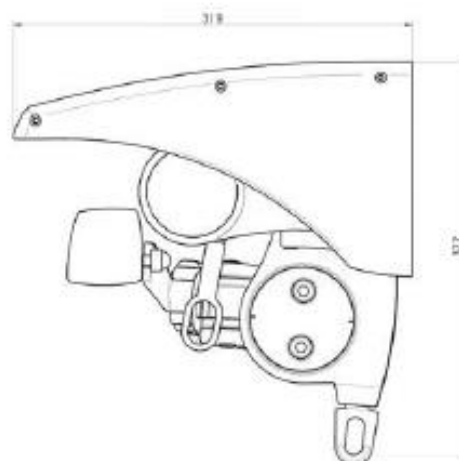

Euro with Roller Valance

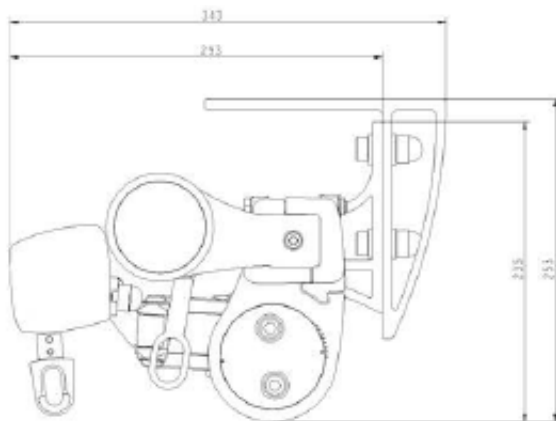

Euro with Roller Vallance & Hood

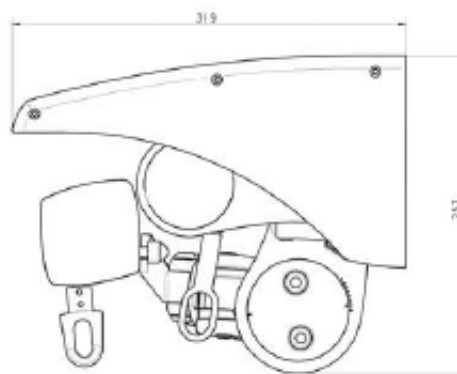

INSTALLATION VIEWS - TE RA ECLIPSE

Eclipse

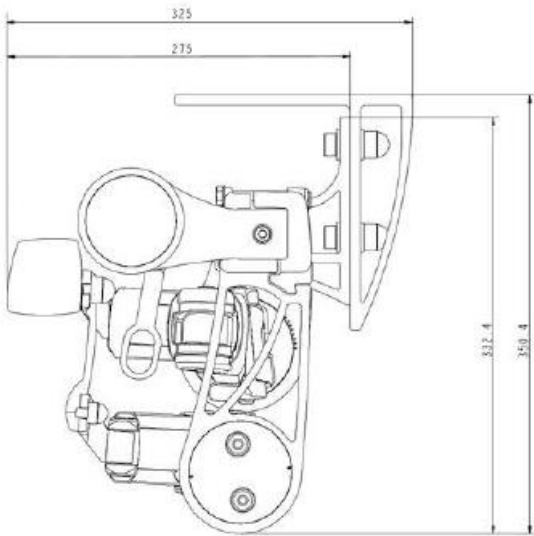

Eclipse with Hood

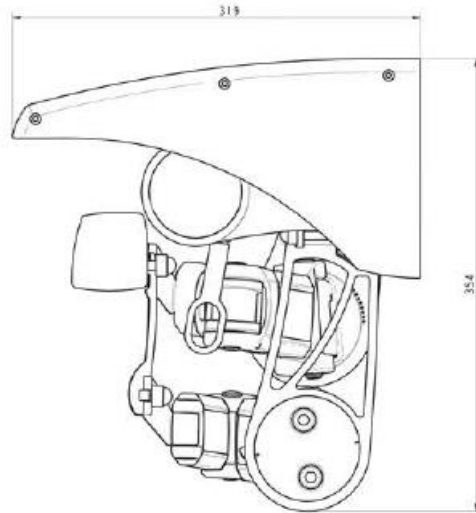

Eclipse with Roller Valance

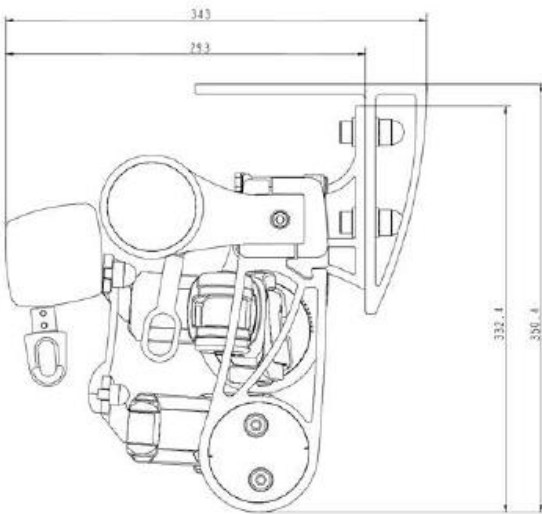

Eclipse with Roller Valance & Hood

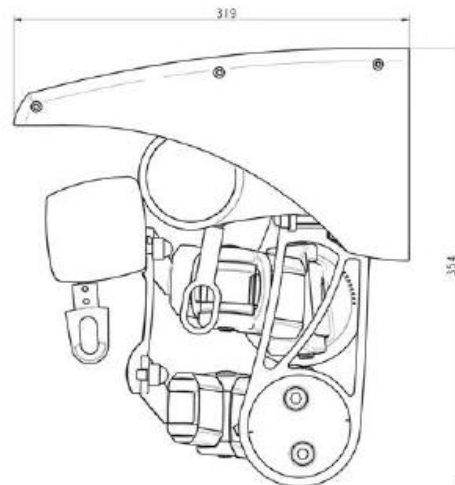

INSTALLATION VIEWS - TE RA BEAM

Beam

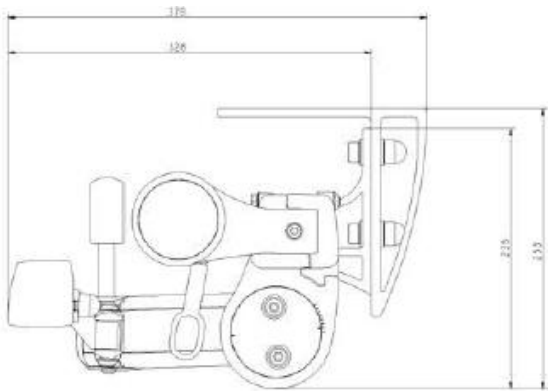

Beam with Hood

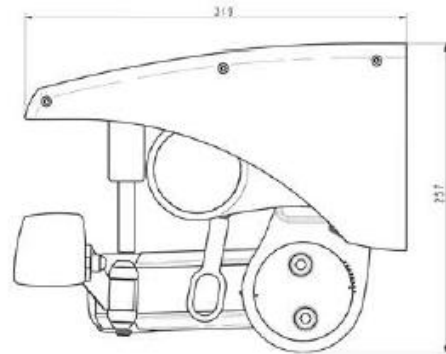

Beam with Pitch Control

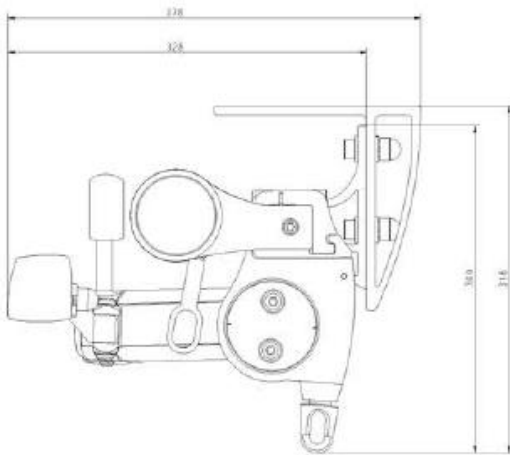

Beam with Pitch Control & Hood

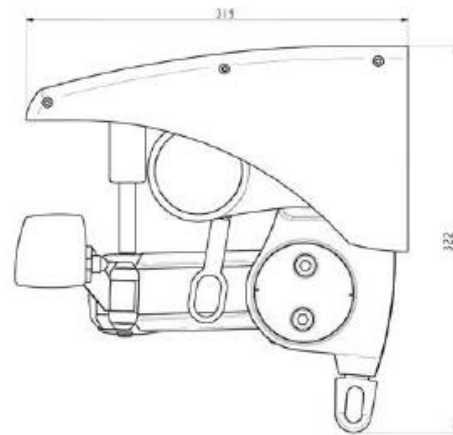

Beam with Roller Valance

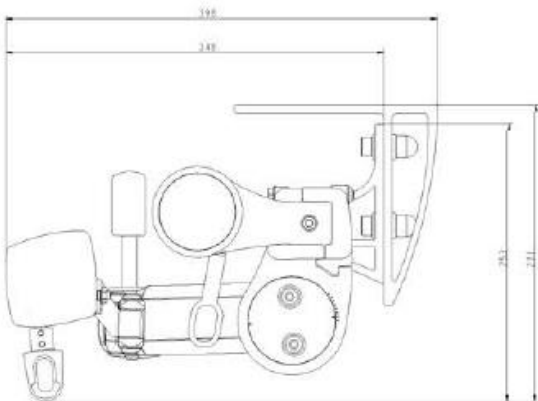

Beam with Roller Vallance & Hood

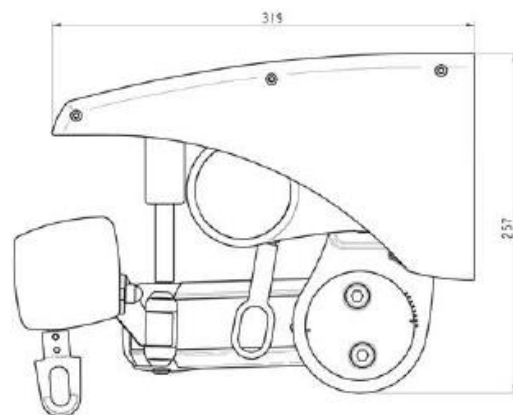

INSTALLATION VIEWS - TE RA VIENTO

Viento

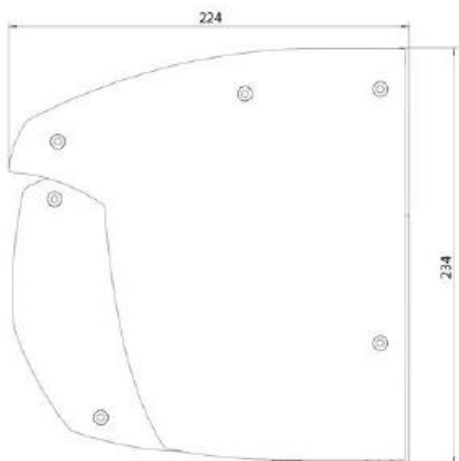

Viento Roof Mounted

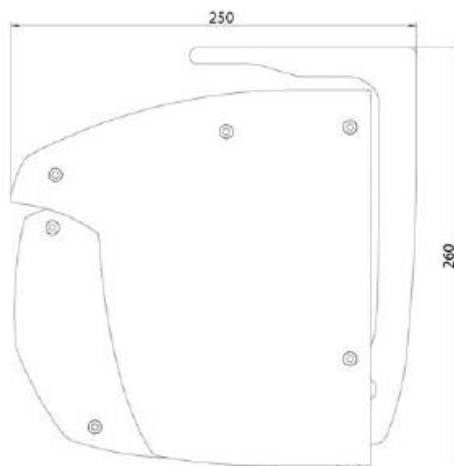

AWNING PITCH

PROJECTION & PITCH DIAGRAM EURO

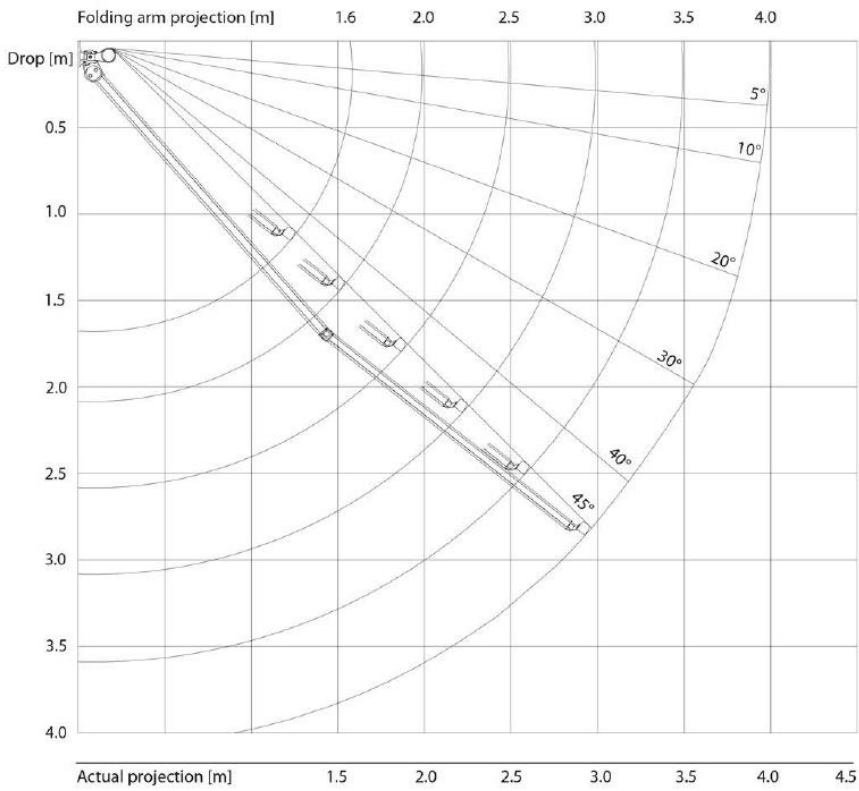

PROJECTION & PITCH DIAGRAM BEAM

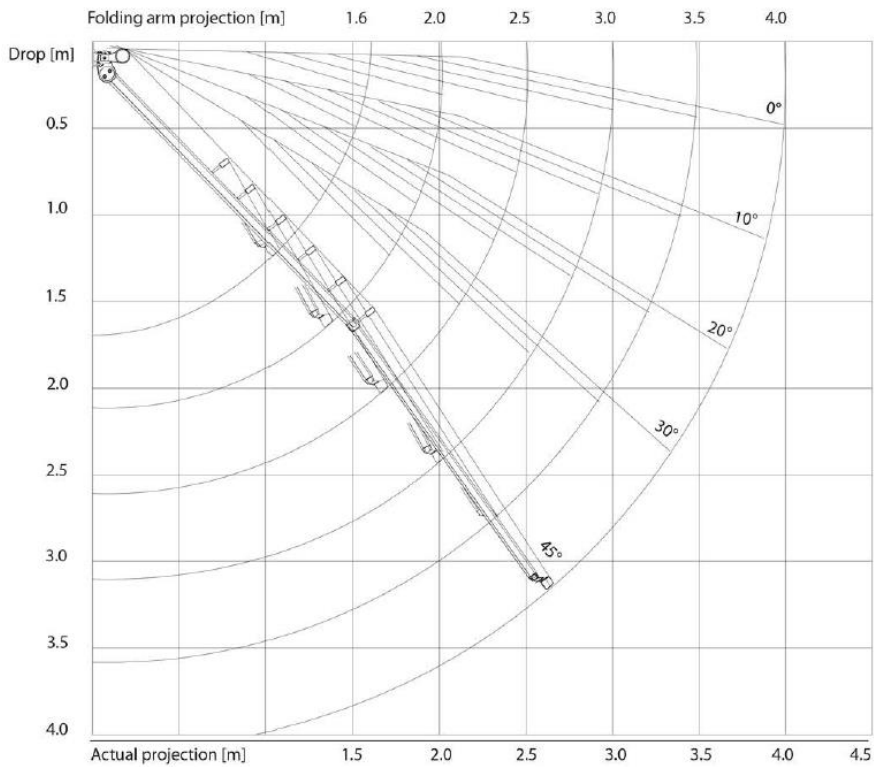

PROJECTION & PITCH DIAGRAM VIENTO

Note: Pitch set at time of installation not user adjustable

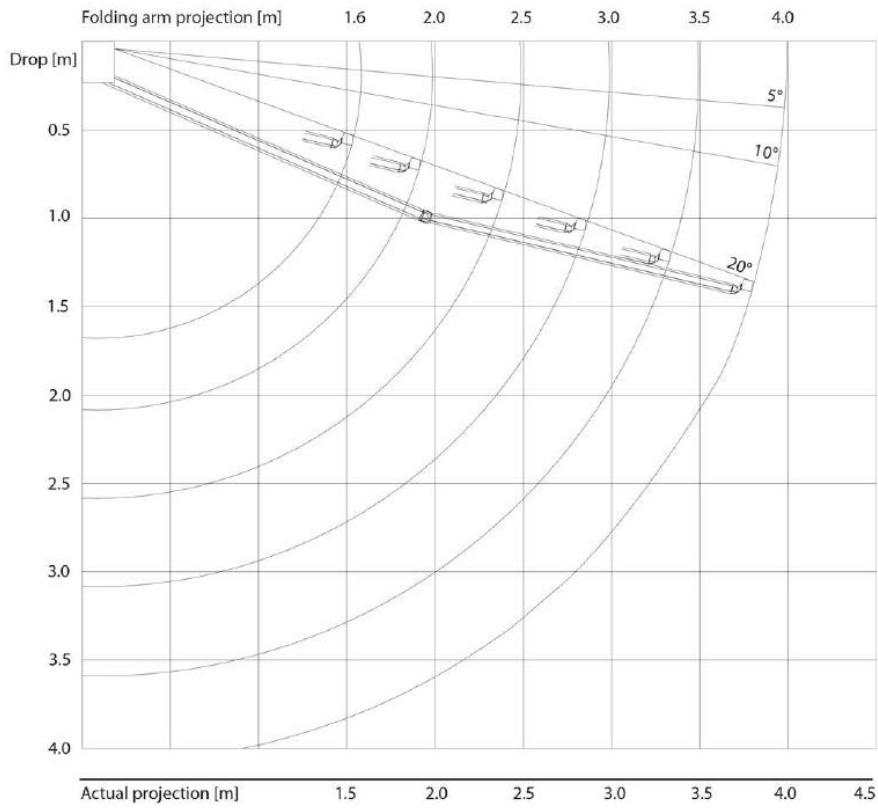

EXPLODED VIEW

TE RA ORIGIN

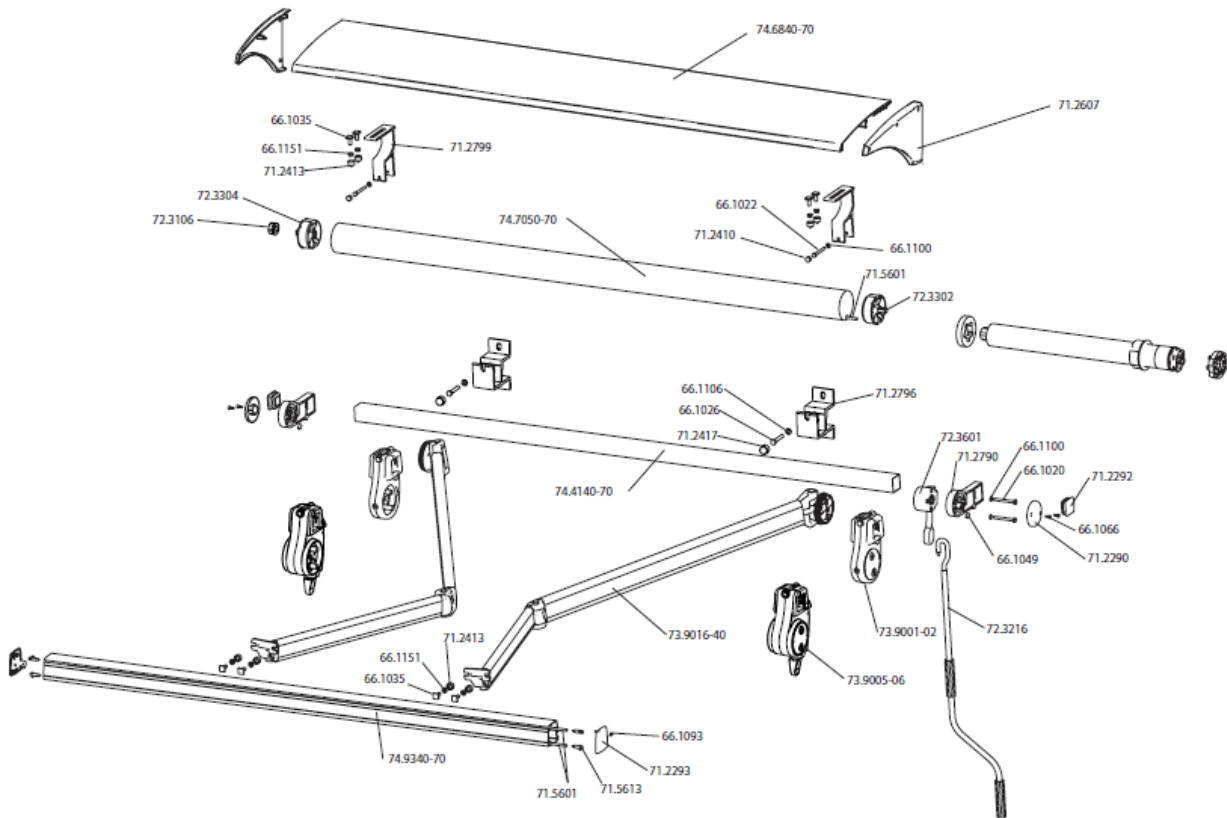

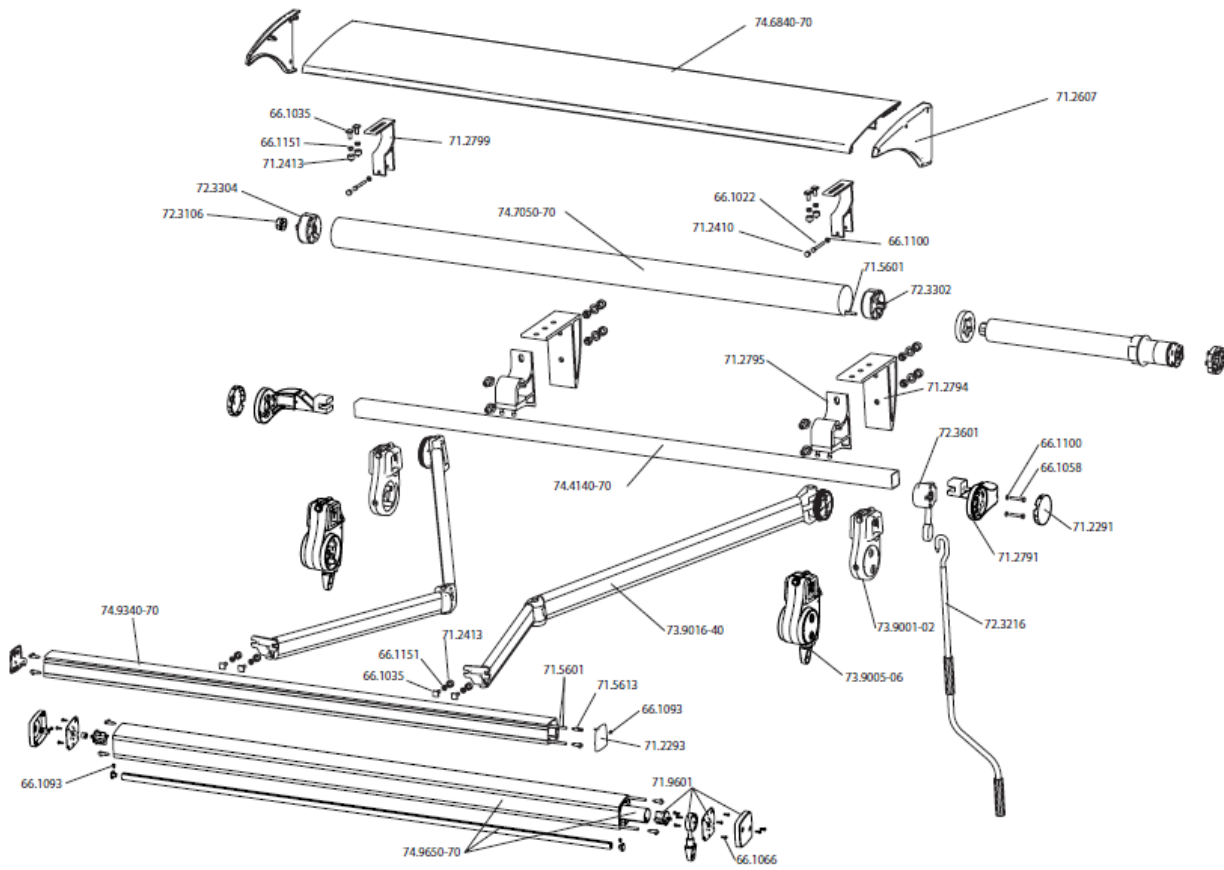

TE RA ECLIPSE

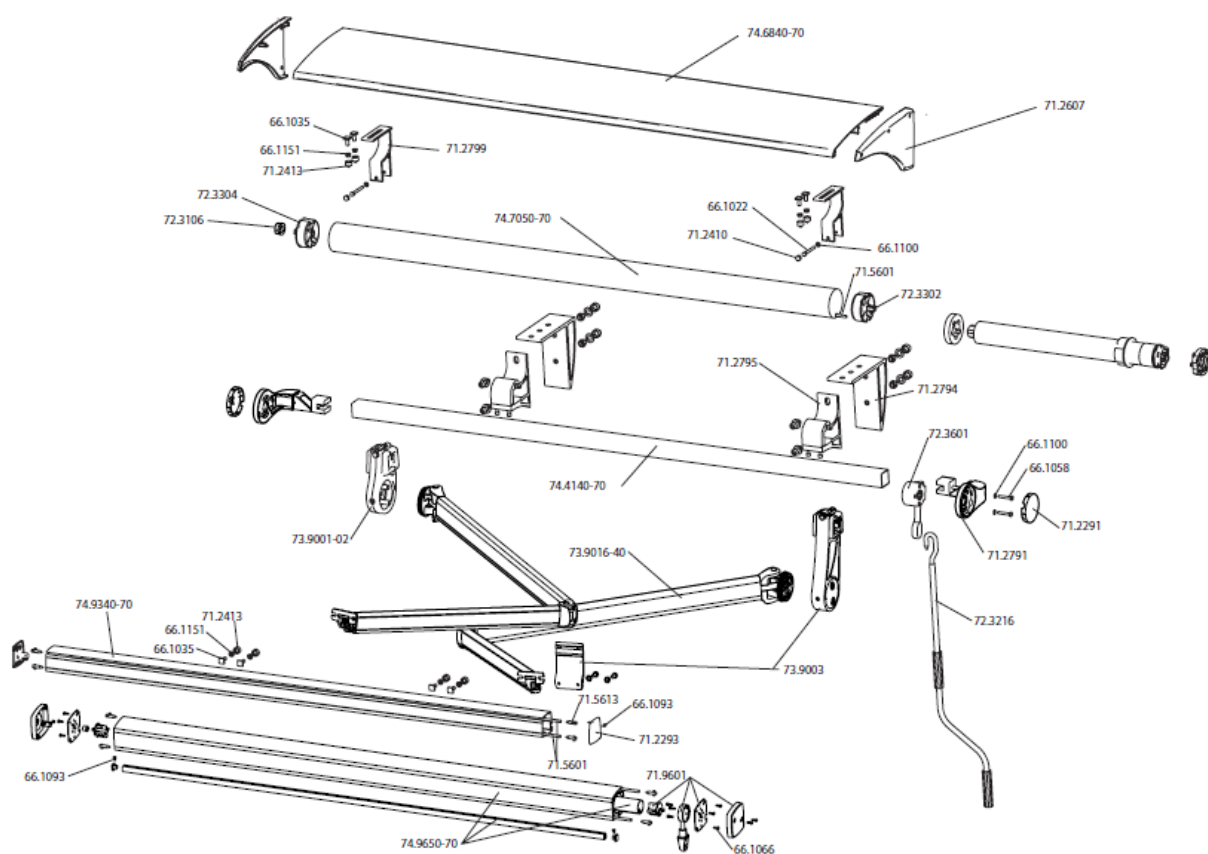

TE RA BEAM

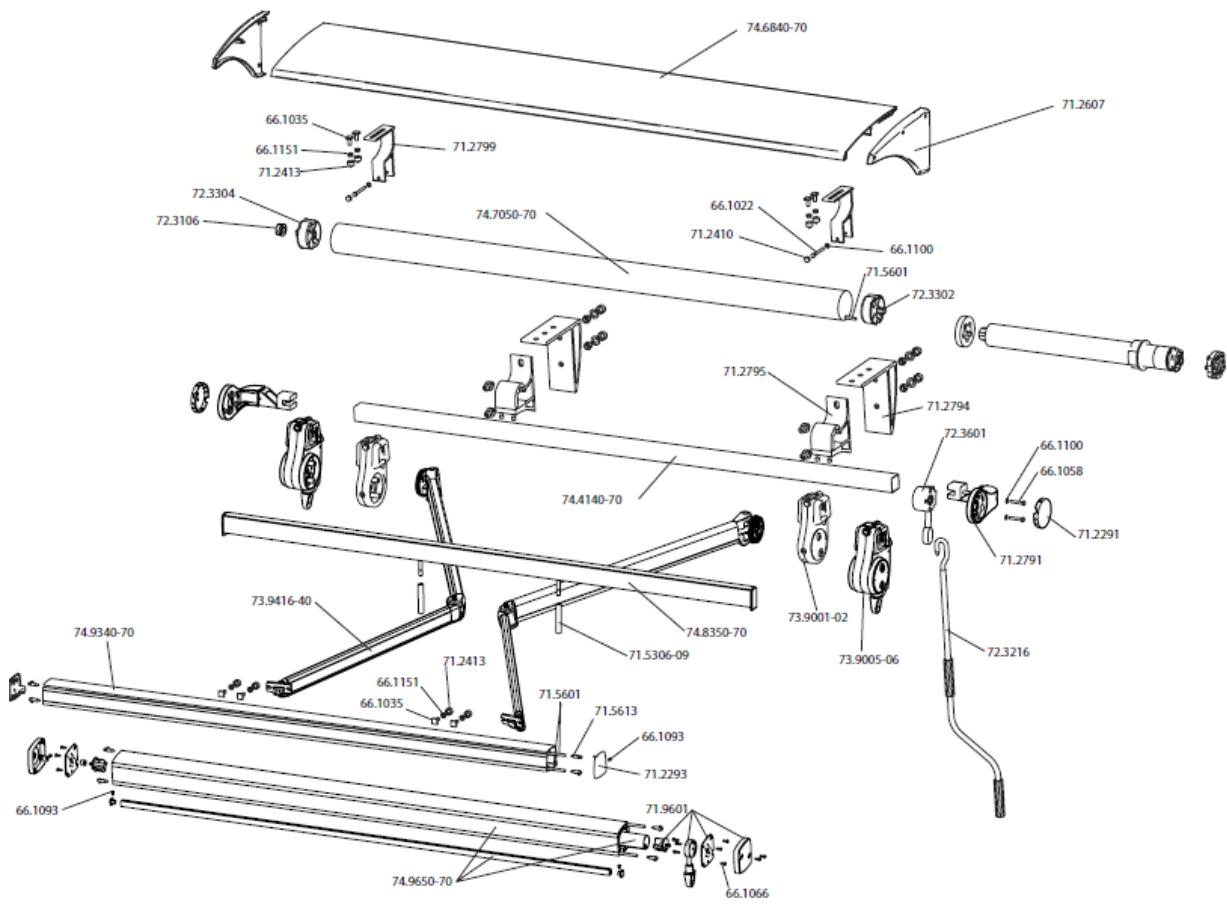

TE RA VIENTO

