

# Glydea Ultra

## PRODUCT SPECIFICATIONS

# The silent and intelligent solution for curtain motorisation

### PRODUCT MAIN FUNCTIONALITIES



**Designed for silence**  
Silent mode and silent accessories.



**Available in multiple technologies**

RTS, DCT, WT and bi-directional technology with RS485 module. (to insert in RTS or DCT version)

RECOMMENDED TO SET WITH:

Universal test lead  
(ref. 9 015 971)



**Soft start and soft stop on RTS and DCT motors**



**Adjustable speed**  
5 speeds available.



**Touch motion**



# Glydea Ultra

## PRODUCT SPECIFICATIONS

### BENEFITS FOR PROFESSIONALS

#### Reliable, robust and discreet

- The premium solution for residential and commercial projects

#### Adaptable & powerful

- Compatible with multiple technologies (WT/DCT/RTS/RS485) to meet the needs of smart buildings and smart homes
- Curtain weight up to 60kg

#### Flexible installation

- Available with inline connector for ease of programming
- Motor can fit either end of the track

### BENEFITS FOR END USERS

#### Elegance

New design for the best aesthetic of the complete solution.

#### Comfort

Enjoy one of the quietest solutions on the market. Open and close smoothly to allow the right amount of light to create a perfect ambiance without disturbing your peace and quiet.

#### Smart and simple

Enjoy your smart home by controlling your curtains with Connexoon Window RTS and voice control (through IFTTT).

### COMPATIBLE END-PRODUCTS

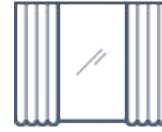

Curtains

### TECHNICAL DATA

<b>Thermal Time</b>	2.5 minutes
<b>Supply</b>	AC
<b>Index Protection Rating</b>	IP30
<b>Limit Switch Unit</b>	Electronic
<b>Temperature Working Range</b>	0°C to +60°C
<b>Electric Insulation</b>	Class I

### PERFORMANCE

End-limit Unit Versions Available	RTS*		DCT*		WT	
	35e	60e	35e	60e	35e	60e
<b>Nominal Torque (nm)</b>	0.6	1	0.6	1	0.6	1
<b>Adjustable Linear Speed (cm/s)</b>	20cm/s / 17.5cm/s / 15cm/s (default) / 12.5cm/s / 7.5cm/s (silent mode)					
<b>Sound level (dBA)</b>	45.2 / 43.4 / 39.7 / 37.3/ 29.8 dBA					
<b>Voltage</b>	230V / 50Hz					
<b>Maximum Current</b>	0.4 A					
<b>Radio Frequency (MHz)</b>	433,42	433,42				
<b>Adjustable Limits</b>	Yes	Yes	Yes	Yes	Yes	Yes
<b>Curtain Maximum Weight</b>	35kg	60kg	35kg	60kg	35kg	60kg
<b>Control Method</b>	RTS		Dry contact via RJ12 socket		AC Switch	
<b>L1 (mm)</b>	348	348	348	348	348	348
<b>Item Number</b>	1240227	1240230	1240226	1240229	1240219	1240228
<b>With inline connector</b>	1241032	1241035	1241031	1241034	1241030	1241033
<b>Dedicated RTS Wall Mounts for Curtain</b>			Smooove 1 Open/Close Black RTS 1811009		Smooove 1 Open/Close White RTS 1811011	

\*compatible with RS485 module (Ref 1870275).

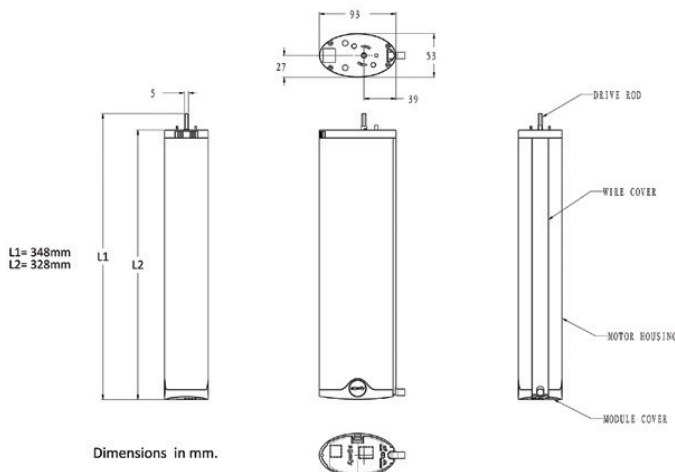

Dimensions in mm.