

# Evo External Screen Awnings Product Manual



*Luxaflex*<sup>®</sup>  
WINDOW FASHIONS

## FEATURES & BENEFITS

### FEATURE

Bottom Rail

### BENEFIT

The multi-functional bottom rail offers a variety of features whilst maintaining a subtle modern design curve to seamlessly blend with the headbox aesthetics

Locking Bolt

Allowing the bottom rail to get close to the ground to minimise light gaps

Hold Down Straps

Hold down straps can be secured at points that best suit the customer's needs and the application.

Insect Brush

The opportunity for light gaps, insects, debris, wind and rain are significantly reduced from entering your protected area

Valance

As an added option, the valance can change the overall look of the Awning based on the consumer's requirements

Concealed Spine Insert

The concealed spline maintains the clean look of the Luxaflex EVO Awning Range meaning an Awning of 5m (W) x 2.9m (D) with Smartshade External Screen Fabric will have no visible welds or joins.

Headbox Options

The Luxaflex EVO Awning Range offers 2 designer headbox options for increased functionality and a modern contemporary look

Open Roller

There is also an open roller option for a cost-effective alternative.

# FABRIC RANGE

## SMART SHADE

- Smart Shade is an exterior sunscreen with a 5% openness factor, providing great strength and stability.
- It offers effective protection from all-weather circumstances: heat, wind, rain and harmful UV rays.
- The contemporary colour palette makes it suitable to any exterior décor.
- Composition of PVC coated Polyester
- Medium Privacy factor
- Excellent Tensile strength and tear resistance
- Easy to clean
- Fire Retardant AS1530 part 2
- Energy efficient
- Mildew resistant
- A total of 10 colour choices

## SMART SHADE ECO

- Smart Shade Eco is a durable exterior sunscreen which allows air flow and lets you see the view with a 5% openness factor.
- This 2 x 2 basket weave fabric offers effective protection from all New Zealand weather conditions: heat, wind, rain and harmful UV rays.
- Composition of 70% PVC
- Medium Privacy factor
- A total of 6 colour choices

## SMART SHADE PLUS

- This exterior sunscreen has a broken twill weave that can protect any outdoor area from heat, UV rays, wind and rain.
- Smart Shade Plus has been designed with one side black, for excellent view-through without glare.
- The other side has a contemporary colour range to suit any exterior décor.
- Composition of PVC coated Polyester
- High Privacy factor
- Excellent Tensile strength and tear resistance
- Fire Retardant AS1530 part 2
- Energy efficient
- Black inside for great view-through
- A total of 8 colour choices

# IMPACT OF SUN ON A HOME

Throughout the day, the sun moves from sunrise in the east through the north sky and sets in the west. This means the amount of heat from the sun received by a window varies according to orientation and time of year. In summer, the sun travels higher through the sky with direct exposure to east and west windows, in winter the sun travels lower with a greater angle through north facing windows. Each home is different - window size, orientation, glazing treatment, shading and internal coverings can have a significant impact on energy efficiency and comfort.

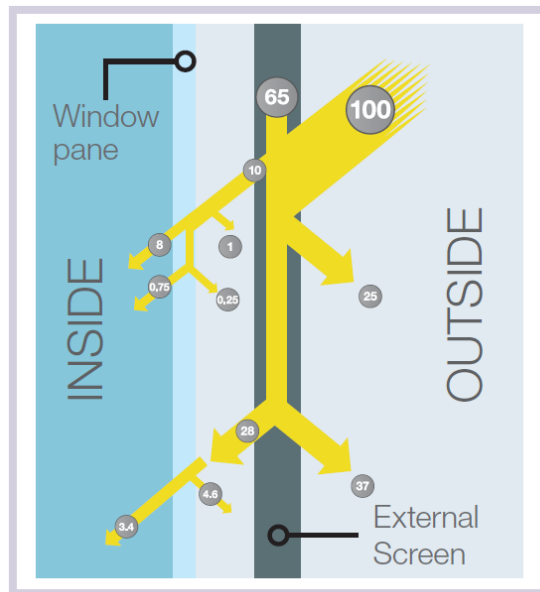

An External Screen shading a window reduces the radiant energy passing through the glass into the room. When the radiant energy touches an object inside it gets hot, making the room hot. Windows are a big source of unwanted heat loss and heat gain in your home.

Choosing the right window coverings means you can improve the comfort of your home all-year-round, reduce your power bills and cut carbon pollution.

## KEEP YOUR HOME COOL IN SUMMER

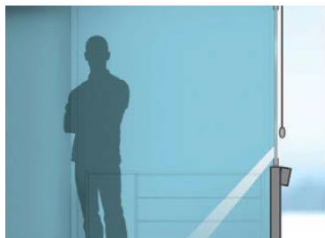

During summer, about half of unwanted heat comes through exposed windows, especially those facing east and west. Shading your windows with EVO External Screens can minimise heat in your home to create a comfortable cooler

environment – and potentially save you hundreds on energy bills.



## KEEP YOUR HOME WARMER IN WINTER



You can control the temperature of your home in winter without relying on power-hungry heating appliances. To make the most of sunny days, open your External Screens on windows facing the sun – this will let in sunlight and warmth, and will help to minimise the need to use your heating system.

Keep the warmth inside during winter using well-fitted insulating window coverings such as Luxaflex Duette Cellular Shades.

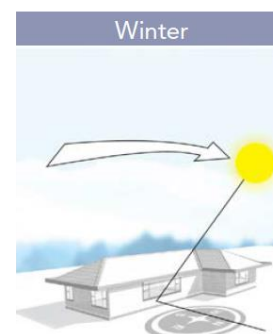

# EVO EXTERNAL SCREEN SYSTEMS

The Luxaflex® EVO External Screen System represents the latest in design, styling and functionality. Offering a full suite of External Screen systems including: Cable Guide, Side Tension Channel (STC), Straight Drop and Pivot Arm, the Luxaflex® EVO External Screen Range offers a common, aesthetically appealing look across all products with a solution to meet every customer's need.

Selected EVO External Screen products can span 5 metres wide in either an enclosed headbox, open headbox or open roller options.

In addition, the Luxaflex® EVO External Screen System has a unique bottom rail that offers consumers added functionality such as: Improved locking bolt, hold down straps, concealed spline inserts, insect brush and the ability to add additional weight bars for windy conditions.



EVO STRAIGHT DROP



EVO CABLE GUIDE



EVO SIDE TENSION CHANNEL



EVO PIVOT ARM

# QUALITY TESTING FOR DURABILITY & STRENGTH

The Luxaflex EVO External Screen System is designed for New Zealand conditions, engineered and independently tested to withstand the harsh New Zealand climate including sun, wind and rain.

## SALT SPRAY TESTING

Testing for corrosion resistance for wet weather.

## WIND LOAD PRESSURE TESTING

Luxaflex EVO External Screens have been tested by an authorised and respected independent organisation to determine the maximum loads the External Screens can withstand before signs of distress and ultimate failure. The table below provides a guide for the wind pressure that these External Screens can withstand. We recommend External Screens are retracted in windy conditions to avoid the potential for damage.

| SCREEN SYSTEM     | PRESSURE (PASCAL) | EQUIVALENT WIND SPEED | EQUIVALENT WEIGHT (kg) |
|-------------------|-------------------|-----------------------|------------------------|
| EVO Straight Drop | 225               | 67km/h                | 185                    |
| EVO Cable Guide   | 225               | 67km/h                | 185                    |
| EVO STC           | 550               | 90km/h                | 453                    |

## CYCLE TESTING

Luxaflex products are cycle tested to replicate daily use for a minimum of 7 years to ensure longevity.

## WEIGHT LOAD TESTING

To ensure strength of all parts are able to withstand the New Zealand environment and conditions.

## UV TESTING

Testing to ensure the colour's fastness when exposed to the damaging UV rays from the sun

## BOTTOM RAIL

The multi-functional bottom rail offers a variety of features whilst maintaining a subtle modern design curve to seamlessly blend with the headbox aesthetics.

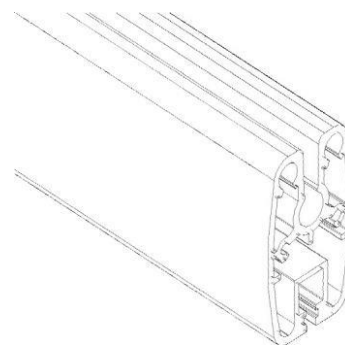

## BOTTOM RAIL WEIGHT BAR

The bottom rail has been designed with a weight of 1.2kg per metre effectively reducing bottom rail flex. With the option to increase the bottom rail weight to 2.2kg per metre the Luxaflex EVO Awning Range keeps fabric taut and assists in minimising bottom rail "bounce" in windy conditions.

## LOCKING BOLT & HOLD DOWN STRAP

With the ability to add locking bolts and hold down straps, the Luxaflex EVO Awning Range offers versatility for holding the fabric secure between the channels and minimising any bottom rail movement in windy situations.

The locking bolt also allows the bottom rail to get close to the ground in order to minimise light gaps.



Hold down straps can be secured at points that best suit the customer's needs and the application. The straps can be placed anywhere across the width of the bottom rail allowing the Awning to be locked into place.

## INSECT BRUSH & VALANCE

With the ability to add the pile brush or a fabric valance to the bottom rail, the opportunity for light gaps, insects, debris, wind and rain are significantly reduced from entering your protected area. This applies only to Channel or STC styles.

The brush and valance also protect the bottom rail from chipping if dropped to the ground quickly. As an added option, the valance can change the overall look of the Awning based on the consumer's requirements.

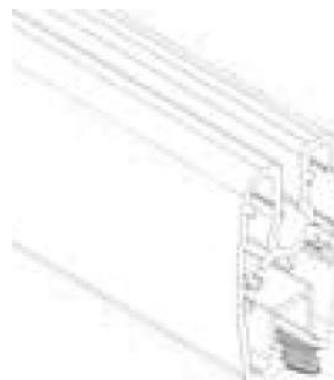

## CONCEALED SPLINE INSERT

The new bottom rail is designed to cover any welds or stitching required to secure the fabric to the blind. The concealed spline maintains the clean look of the Luxaflex EVO Awning Range meaning an Awning of 5m (W) x 2.9m (D) with Everscreen External Screen Fabric will have no visible welds or joins.



# HEADBOX & OPEN ROLLER OPTIONS

Luxaflex EVO External Screen Systems offer two designer headbox options for increased functionality and a modern contemporary look. There is also an open roller option for a cost effective alternative.

## CLOSED HEADBOX

The closed headbox protects the fabric from external elements such as rain, UV and debris. This assists in keeping the fabric clean and enhances longevity.



## OPEN HEADBOX

The open headbox is used for the pivot arm awning. In addition, the open headbox also allows more air to circulate around the roller thereby minimising heat build-up. The open headbox is also ideal for installations where there are obstructions preventing back milled products and is ideal for front rolled Cable Guide Awning.



## OPEN ROLLER

A cost-effective option is the open roller system which offers a modern industrial look by exposing the operation componentry. By eliminating the aluminium headbox profiles, the price is reduced making it the ideal choice for the cost-conscious consumer.





# OPERATING OPTIONS

The Luxaflex EVO External Screen System has been developed to offer maximum flexibility and ease of use for consumer operation.

## MANUAL CRANK

The 9:1 ratio gear ensures easy operation that is not dependent on the user's strength. Specifically designed for straight drop applications the 9:1 ratio gear can withstand high wind situations and is available in a selection of Black, Grey and White for improved colour co-ordination with most fabrics.



There is a great range of crank handles available in: 1000mm, 1200mm, 1400mm, 2000mm and 3000mm lengths.

## AUTOMATION

A range of external motor solutions including the latest Solar technology, allow the Luxaflex EVO External Screen Range to be operated at the touch of a button or via a wall switch control. We use an Automatic Tensioning Motor that permits the External Screen to be locked in position (with strap or locking bolt) and tensioned as well as obstacle alert which will stop the awning from operating if there is an obstacle in the way e.g. chair etc. Optional accessories include sun and wind sensors, integration into home automation systems providing intelligent External Screen control.)



## SPRING CONTROL

An option available with Side Tension Channel systems which allows you to manually lift the awning up and down. Due to this operation being on a spring, one of the locking systems is strongly recommended. It is important to ensure that the customer is able to reach the bottom rail when the awning is fully retracted.

## INSTALLATION

The Luxaflex EVO External Screen System can be installed in different applications, including face, top or side fixing.

By using the same universal bracket in both headbox and open roller configurations, installation is kept simple and consistent. To improve installation flexibility. An additional mounting plate (spreader) is available that can alter the fixing position by up to 250mm.

# INSTALLATION APPLICATIONS



Spreader plate

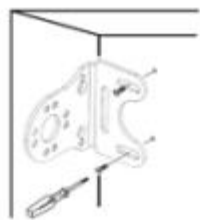

Face



Top



Side

## SIDE TENSION CHANNEL (STC)

The Luxaflex EVO STC External! Screen is a premium and versatile Straight Drop option ideal for sun/UV protection, insect resistance, windy applications, enclosing a balcony, as well as light and heat control.

The fabric is tensioned by utilising a floating channel and is ideal for enclosing courtyards, patios or balconies, essentially adding an extra room to the home as well as eliminating fabric blowouts. Two Piece Side Channel - By utilising a common installation channel the front channel simply snaps over the installation channel to provide a neat, clean finish meaning no screws and rivets are visible.

### FLEXIBLE INSTALLATION

The floating channel creates installation flexibility as the fabric can “float” within the side channel and accommodate some out of square mounting surfaces and fabric shrinkages. The floating channel feature will also move with the wind and take strain off the welds and joins in the fabric. Clever sound bumpers have been incorporated into the floating channel to minimise noise when operating or in windy conditions.

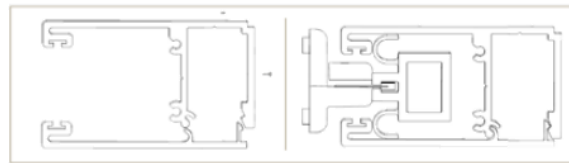

### TUBE REDUCERS

There is potential for fabric thickness build up at the end of the roller as the External Screen is raised. The use of custom designed tube reducers minimises this build up, thereby ensuring the fabric rolls as symmetrically as possible, whilst the External Screen is in operation. This keeps the fabric flat and reduces the rippling effect.

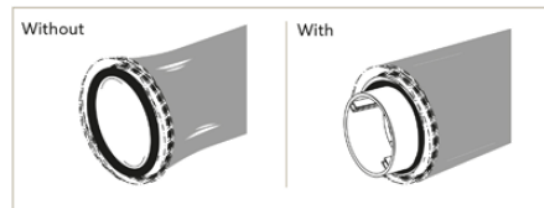

### LOCKING BOLTS

The locking bolt can be used with all Luxaflex EVO External Screen Systems. The locking bolt allows you to secure the bottom rail by simply sliding the bolt into the selected hole position in the side channel or post. This feature holds the fabric taut and minimises bottom rail movement.

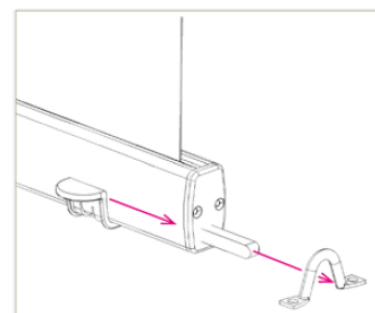

## CABLE GUIDE

The Luxaflex EVO Cable Guide External Screen is a great contemporary Straight Drop option ideal for sun/UV protection, air flow and where channels are not suitable. The cables are made of high tensile 2.5mm 316 grade marine stainless steel making them perfect for coastal applications.

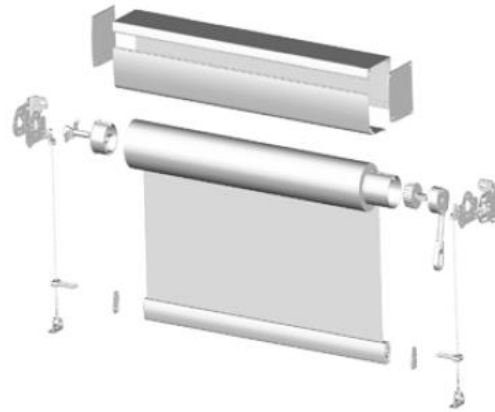

The Luxaflex Eva Cable Tensioner set has been designed for adjusting at the bottom of the External Screen thereby reducing the need to be up a ladder. Simply install the universal bracket to the floor or parallel to the top cable bracket. Loosely attach the cable swage at the bottom, carry the cable to the top cable bracket and lock off. Return to the bottom of the External Screen and tighten the swage to add additional tension.

## BOTTOM RAIL END CAPS

Have been designed to float to accommodate instances where the cable is not straight, creating a smooth operation without putting pressure on the cable.

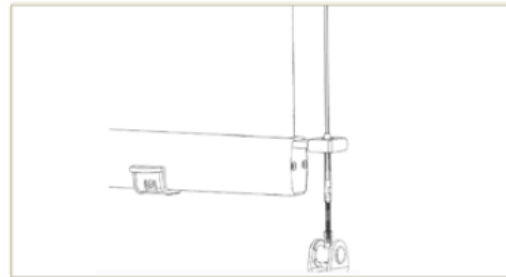

## LOCKING BOLTS

Locking bolts can be used with the Cable Guide System when the External Screen is fully lowered. The locking bolt simply inserts into the universal floor and wall mount bracket to hold the fabric taut and minimises bottom rail movement.

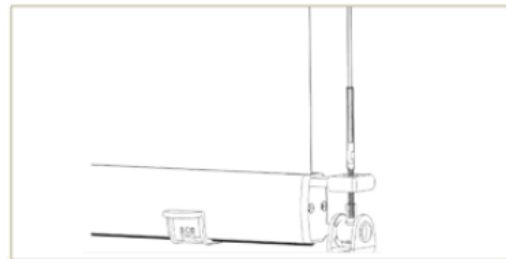

## EXTENSION PLATE/Front ROLL

The extension plate combined with the open headbox can be used with the cable guide External Screen for front roll applications. It can also assist with top and reveal fit installations by making the top cable bracket more accessible.

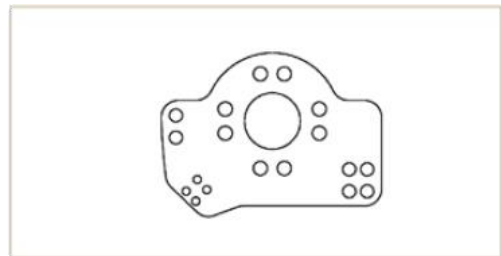

## STRAIGHT DROP

The Luxaflex EVO Straight Drop External Screen is a traditional External Screen style that uses no guides making it ideal for: sun/UV protection, air flow and where channels are not suitable. The External Screen is strapped down to a railing or floor. The absence of side channels or cable guides means it is priced as an entry level product for the Luxaflex EVO External Screen System.

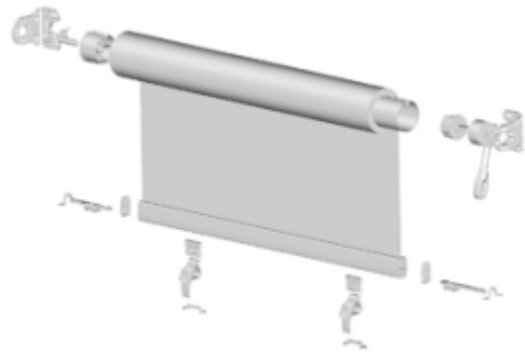

### HOLD DOWN STRAPS

Hold down straps can be used to hold the External Screen down to a railing or floor at various points across the width of the screen giving maximum flexibility for installation.

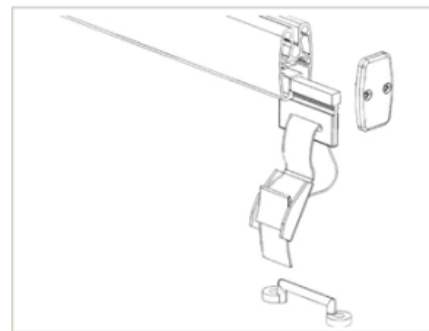

### LOCKING BOLTS

Locking bolts can be used to secure the External Screen at the ends of the bottom rail. With the Straight Drop External Screen, you can use the locking bolts to either insert into a reveal/post situation or alternatively use a breaching staple on the ground or balcony for the bolt to slide under.

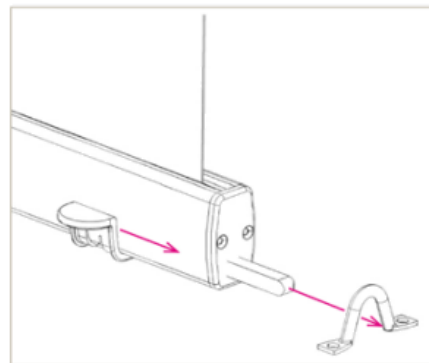

# INSTALLATION OVERVIEW

A key focus for the Luxaflex EVO External Screen System is easy installation. All systems share the same headbox/open roller installation procedure making it quick and easy regardless of the product type being installed. Each individual system then has its own unique process for installing the guiding method:

## STRAIGHT DROP SCREENS

Especially easy to install – for the strap down and locking bolt options, secure breaching staples in appropriate location to ensure the locking mechanism can engage.

## CABLE GUIDE SCREENS

Developed for cable tension to be adjusted from the bottom of the External Screen thereby reducing the need to be up a ladder. Simply install the universal bracket to the floor or wall, attach the cable swage lightly at the bottom, secure cable in the top bracket, then return to the bottom swage and adjust the cable tension.

Can be installed in face or side fit situations. The installation centres have been marked on the extrusions and installers need to determine the appropriate position for securing to the installation surface. Once secured and the fabric is within the channel, simply snap on the channel cover extrusion.

## STC EXTERNAL SCREENS

Follow a similar method to the channel system with the addition of 'ZIPS' attached to the sides of the fabric. They slide into an additional floating channel that is secured inside, before sliding the front channel cover extrusion.

# OPTIONS & SPECIFICATIONS

## STANDARD HARDWARE COLOURS



\*Custom Powdercoat options available

## External Screen Fabric Options & Specifications

| FABRIC      | ROLL WIDTH                                 | COMPOSITION              | NO. OF COLOURS |
|-------------|--|--------------------------|----------------|
| Planasol    | 1200mm<br>(Limited colours at 2050mm wide) | 100% Acrylic Woven Fibre | 56             |
| Smart Shade | 3200mm                                     | PVC Coated Polyester     | 22             |
| PVC         | 1500mm                                     | 100% PVC                 | 1 (Clear)      |

## QUALITY

EVO componentry is designed and engineered for the New Zealand market, making it ideal for our unique climate conditions. The system is manufactured using strict quality control and inspection processes to ensure the product exceeds consumers expectations. Backed by a 3-year warranty, customers can have peace of mind on the longevity of their external shading solution.

## FABRIC RAILROADING

Fabric is railroaded when the total width of an EVO Awning exceeds the standard width of the roll of fabric.

We will join fabrics when the need to railroad is required. If the fabric is railroaded, and the drop exceeds 2500mm, the weld will be located at the top of the screen to minimize this being seen by your customer.