

Alpha External Screen Awnings Installation Manual



Weathermaster®

This Product Manual is only a guide to the measurement and installation.

New Zealand Window Shades Limited does not warrant the accuracy contained in this manual.

The information contained in this Product Manual is based on the measurement and installation data known to us at the time of issue of the Product Manual and is therefore subject to changes or amendments at any time without notice, and the right to change or amend is hereby expressly reserved by New Zealand Window Shades Limited.

IMPORTANT

This Product Manual at all times remains the property of New Zealand Window Shades Limited.

Its contents are strictly confidential and may not be reprinted, copied, reproduced or multiplied in any form. This Product Manual must be maintained in its original form and must be returned to New Zealand Window Shades Limited upon first request. New Zealand Window Shades Limited is not responsible to you or anyone else for any loss suffered in connection with the use of this product manual or any of the content.

SAFETY & WARNING ADVICE

A minimum of 2 people is necessary for proper installation.

PLEASE NOTE:

Installation fixings will NOT be supplied with any of the Alpha Awning Series. Please refer to fixing section. Each installation should be assessed on a case by case scenario.

WARNING! - The brackets must be fixed solidly to a substantial surface. Hollow bricks or foam products are not suitable. Brick veneer surfaces require at least 2 courses of brickwork above the bracket and 2 courses below.

GENERAL ADVICE







The electrical data is shown on the label of electric operating awnings.

Tools: The following tools are required for installation:

- Level
- Battery Drill
- Screwdrivers
- Hammer Drill
- Drill Bits
- Spanner - 7mm (size of open-end spanner for top aligner)
- Allen Key

FIXINGS

Due to possible differences in specification, application and interpretation of results, users must make their own evaluation of the product to determine the suitability of fixings and their intended use.

ITEM	TITLE	DESCRIPTION
	<p>Counter Sunk (Zenith) 10g x 50mm Available in Metal or Timber thread Stainless</p>	<p>Used to side fix channels.</p>
	<p>Waffer/Button Head (Buildex) 8g x 50mm Available in Metal or Timber thread</p>	<p>Used to face fix channels.</p>
	<p>Roofing & Cadding Hex Head (Buildex) 12g x 50mm Available in Metal or Timber thread</p>	<p>Used to fix universal brackets.</p>
	<p>Counter Sunk (Zenith) 10g x 50mm Available in Metal or Timber thread Stainless</p>	<p>Used to fix wire guide bottom bracket.</p>
	<p>Ramplug/Green Plug (Ramset) 50mm Length</p>	<p>Used to fit to brick or concrete</p>
	<p>Dyna Bolt (Ramset) 6m x 30mm</p>	<p>Used to face fix channels.</p>
	<p>Dyna Bolt (Ramset) 8mm x 50mm</p>	<p>Used to fix universal brackets.</p>
	<p>Counter Sunk (Ramset) 4.5mm x 30mm Stainless</p>	<p>Used to fix wire guide bottom bracket.</p>

CHARATERISTICS OF AWNING FABRICS

Some slight fabric curling may occur on fabric edge on large applications, whilst the following characteristics are considered normal occurrences.

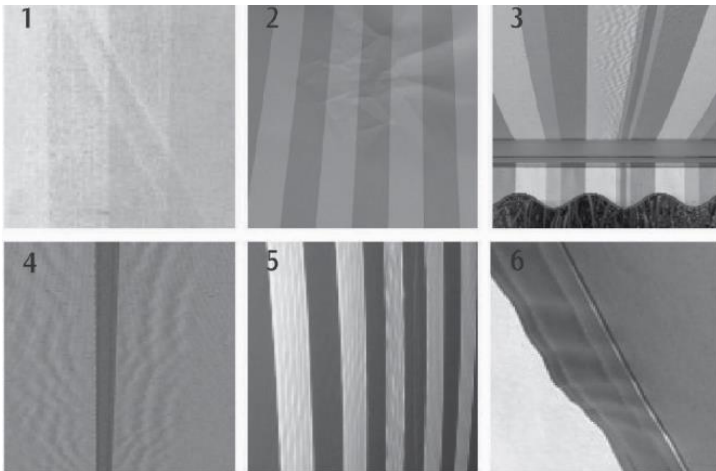

- Creasing (Figs. 1, 2)
- Puckering (Figs. 3, 4 & 5)
- Tension Induced Stretching (Figs. 6)



OPTIONS & LIMITATIONS

	CRANK GEAR	MOTORISED
OVERALL MAX WIDTH	5000mm	5000mm
OVERALL MAX DROP	4000mm	4000mm
OVERALL MIN DROP	300mm	300mm
MAX AREA	16 Sqm	16 Sqm

MEASURING INSTRUCTIONS

Accurate measuring of the Alpha Awning Series is vital for successful fitting and consequential use. The product can be fitted on Face or Inside fixing applications and can be operated by crank control or Automation.

COMPONENT DIMENSIONS

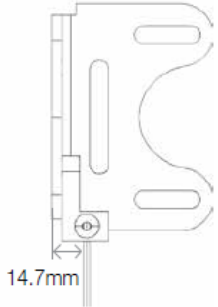
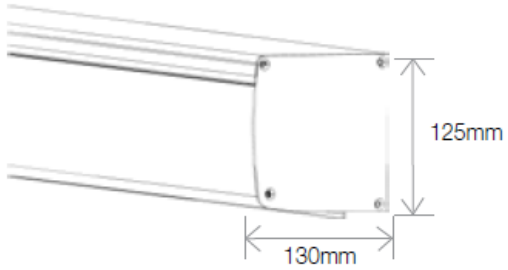
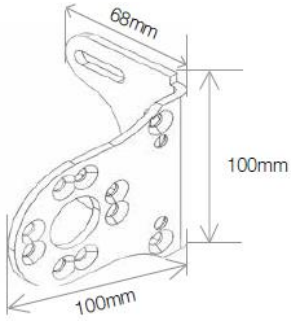
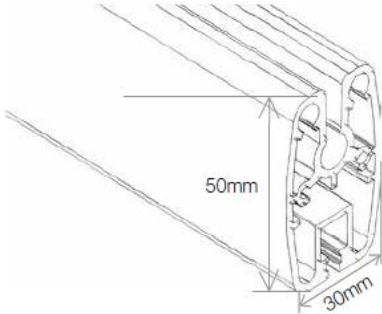
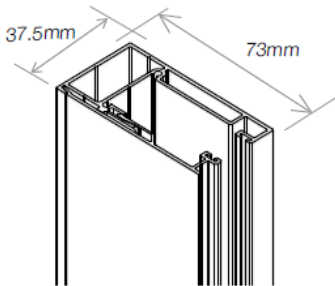
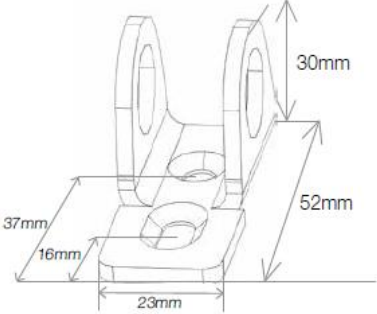
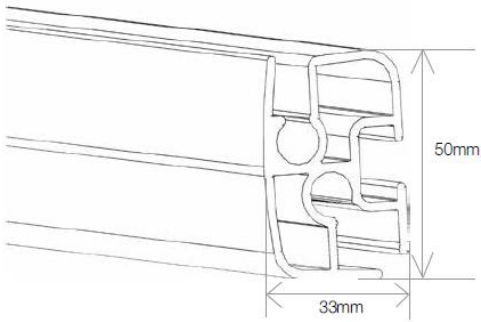
	
<p>CABLE GUIDE</p>	<p>HEADBOX</p>
	
<p>UNIVERSAL INSTALLATION BRACKET</p>	<p>BOTTOM RAIL</p>
	
<p>STC SIDE CHANNEL</p>	<p>BOTTOM CABLE BRACKET</p>
	
<p>PIVOT ARM FRONT RAIL</p>	

OPEN ROLLER INSTALLATION

STEP 1 - MARK FIXING HOLES FOR THE FIRST BRACKET



STEP 2 - DRILL FIXING HOLES



STEP 3 - INSTALL THE FIRST BRACKET



STEP 4 - MEASURE OVERALL WIDTH



STEP 5 - REPEAT STEPS 1, 2 & 3 FOR THE SECOND BRACKET

STEP 1/2/3/ - FACE FIT INSTALL

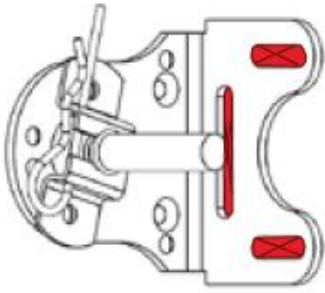

IDLE END

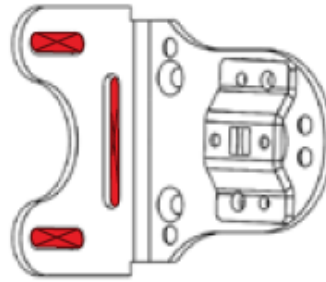

DRIVE END

REVEAL FIT INSTALL

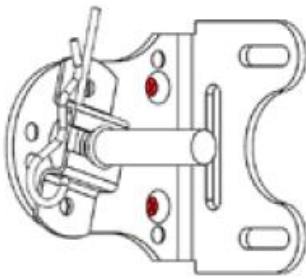

IDLE END

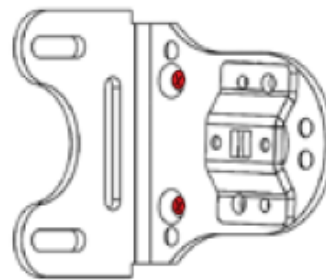

DRIVE END

CEILING FIT INSTALL

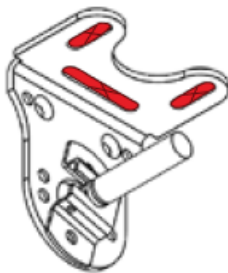

IDLE END

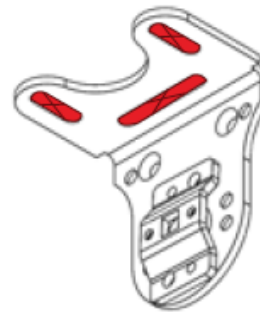

DRIVE END

Brackets will come pre-assembled with idle and drive end components attached. The orientation of these components on the brackets will be determined by the fixing orientation specified on the order form. Example: Face/Reveal, Ceiling.

- Mark the fixing holes for the first bracket.
- Drill holes to suit the method of fixing determined by the substrate being fixed to.
- Screw the first bracket in place. Ensure the bracket is installed straight using a spirit level. If required, pack out the bracket.
- Repeat process for the second bracket.
- Ensure both brackets are installed level and the distance apart is enough for the roller tube to be inserted. The distance between the brackets should be the ordered overall measurement from outside of bracket to outside of bracket.

HEADBOX INSTALLATION

STEP 1 - OPEN THE HEADBOX



STEP 2 - REMOVE ROLLER TUBE



STEP 3 - MARK & PRE-DRILL HEADBOX BACK PANEL
- MARK FIXING HOLES ON INSTALLATION SURFACE
DRILL FIXING HOLES ON INSTALLATION SURFACE
- INSTALL HEADBOX THROUGH BRACKETS

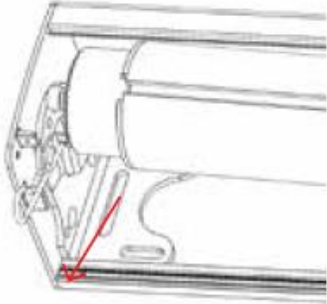
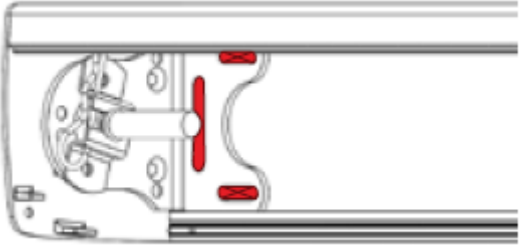
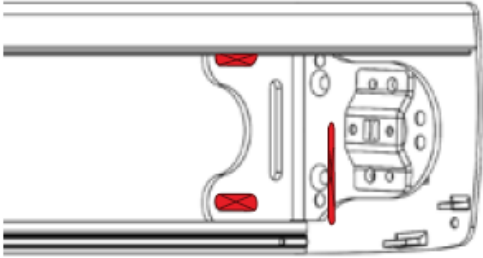
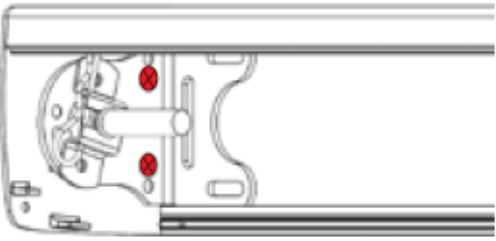
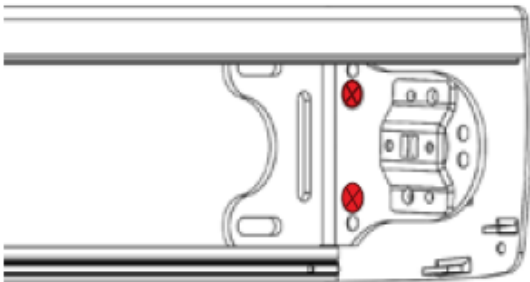

ACCESSORIES
INSTALLATION SPREADER PLATE
PLEASE REFER TO RELEVANT SECTION FOR INSTRUCTIONS

STEP 1 - OPEN THE HEADBOX	STEP 2 - REMOVE ROLLER TUBE
	
<p>Open the headbox front cover by unscrewing the bottom screw on the headbox end cap. Repeat on opposite side.</p> <p>Note: For reveal fit, the screw is no longer required</p>	<p>Pull out the idle end locking pin and remove the roller tube idle end first.</p>
STEP 3 - FACE FIT INSTALL	
	
IDLE END	DRIVE END
STEP 3 - REVEAL FIT INSTALL	
	
IDLE END	DRIVE END

STEP 3 – CEILING FIT INSTALL

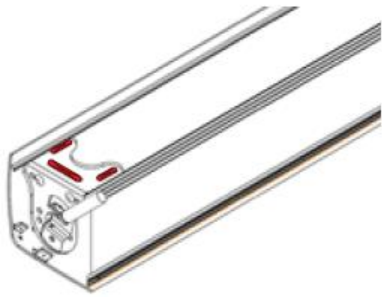

IDLE END

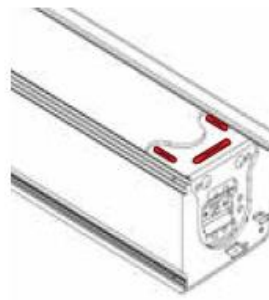

DRIVE END

Mark and drill the head box back plate where the fixings will go.

NOTE: Always secure the headbox back panel through the installation brackets or spreader plate!

- After determining the exact position of the headbox you can fasten the brackets and headbox on the installation surface.
- Mark the fixing holes for the first bracket.
- Drill holes to suit the method of fixing determined by the substrate being fixed to.
- Secure installation screw in bracket to hold one side of head box.
- Repeat the process for the opposite bracket and ensure that the head box is straight using a spirit level.

NOTE: If required pack out the headbox.

- Once satisfied the headbox is level, secure remaining fixing points.

NOTE: For awnings over 3500mm wide, add an additional fixing point through the centre of the headbox back panel.

E.g. 3500mm wide secure at 1750mm.

ACCESSORIES

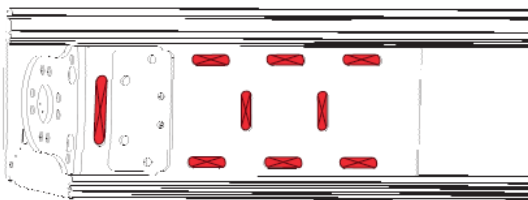

SPREADER PLATE

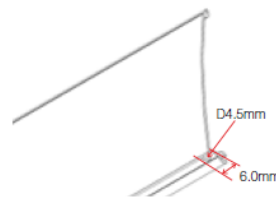

OPEN HEADBOX

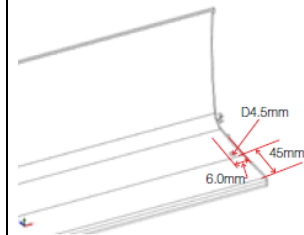

CLOSED HEADBOX

If there is no substantial fixing point at the ends of the headbox, a Spreader Plate can be added. This allows 250mm of flexibility for installation points at each end of the awning. If a spreader plate is ordered, this will come preassembled to the bracket inside the headbox determined by the installation type specified. Secure through Fixing points highlighted in the image.

A 4.5mm hole needs to be drilled in the headbox cover in REVEAL applications. Location of hole, refer to diagram above.

INSTALLING THE ROLLER TUBE



STEP 1 - INSTALL THE DRIVE END



STEP 2 - INSTALL THE IDLE END

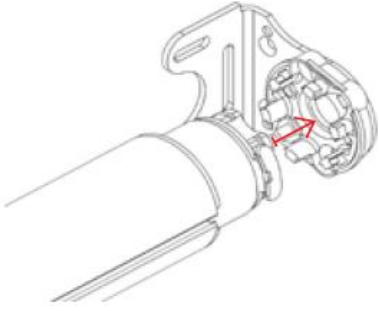
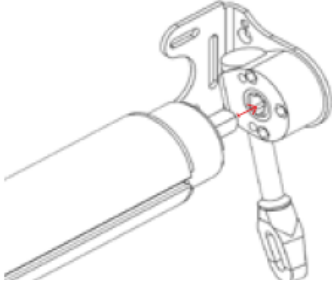
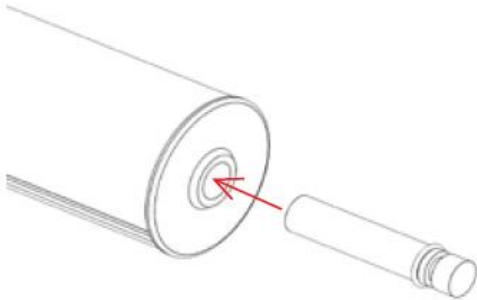
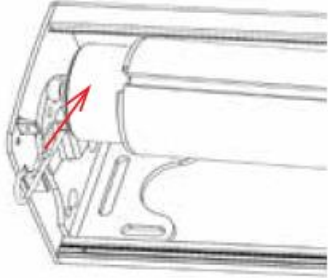

OPTIONAL: STEP 3 - ATTACH THE HEABOX COVER

STEP 1 - MOTORISED	STEP 1 - CRANK
	
<p>Motorised - Insert motor into motor bracket then secure using motor clip</p>	<p>Crank - Insert crank pin into crank gear</p>
STEP 2 - INSERT PIVOT PIN	STEP 3 - INSTALL THE ROLLER
	
<p>Insert Pivot Pin into idle end on tube</p>	<p>Lift Roller over the installation bracket and down so pivot pin sits inside the pivot plate. Insert idle locking pin to secure roller. *Operate the awning a couple of times to ensure tracking and correct operation of the awning</p>
OPTIONAL: STEP 4 - ATTACH THE HEADBOX FRONT COVER	
	
<p>Once satisfied, reattach the headbox front cover</p>	

ALPHA STRAIGHT DROP

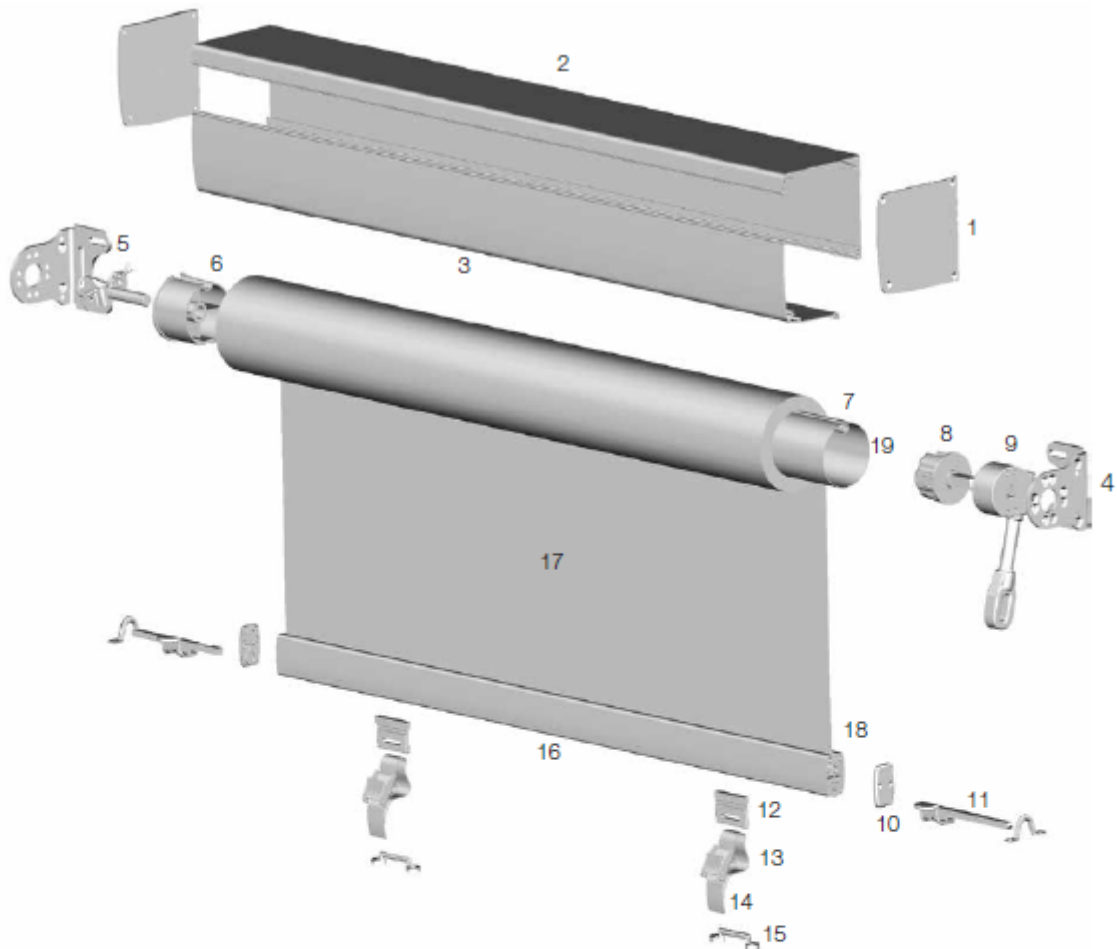

No	Part	Description
1	46.608.XXX	HEADBOX END CAP LH & RH
2	46.005.XXX	HEADBOX BACK PLATE
3	46.012.XXX*	R HEADBOX FRONT COVER (CLOSED)
	46.013.XXX*	R HEADBOX FRONT COVER (OPEN)
4	46.019.XXX	100MM UNIVERSAL BRACKET
5	46.002.XXX	PIVOT PIN & PLATE
	46.506.000	60MM IDLE END
6	44.210.000	70MM IDLER WITH HOLE
	46.507.000	78MM IDLE END
	42.180.049	60MM TUBE
	46.522.500	70MM TUBE 5MT
7	46.522.700	70MM TUBE 7MT
	46.521.500	78MM TUBE 5MT
	46.521.700	78MM TUBE 7MT
	42.603.855	60MM DRIVE END - SMALL
	44.209.000	70MM DRIVE END
8	46.504.000	78MM CRANK DRIVE END
	46.505.000	60MM DRIVE END - 13MM SHAFT

No	Part	Description
9	46.502.XXX	9:1 GEAR
10	46.524.000	PLAIN BOTTOM RAIL END CAP
11	46.517.000	R BOTTOM RAIL LOCKING PIN
12	46.500.000	HOLD DOWN CLIP
13	42.236.000	BUCKLE FOR HOLD DOWN STRAP
14	42.230.000	RUA STRAP
15	42.204.000	BREECHING STAPLE
16	46.011.XXX	R BOTTOM RAIL
17	82.29X.XXX	CANVAS FABRIC
	44.XXX.XXX	EXTERNAL SCREEN FABRIC
18	44.132.000	4.2MM ES SOLID SPLINE
	42.421.855	6MM SPLINE
19	42.198.000	3.5MM HARD SPLINE
	42.421.855	6MM SPLINE

ALPHA STRAIGHT DROP INSTALLATION

STEP 1
i - OPEN ROLLER INSTALL
ii - HEADBOX INSTALL



STEP 2
INSTALL ROLLER TUBE

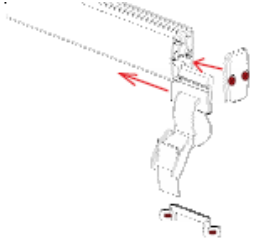
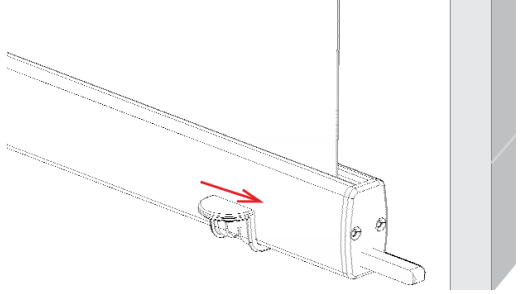
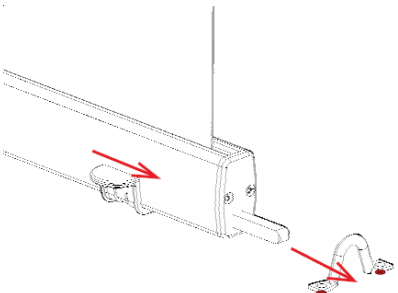

STEP 3
i - INSTALL HOLD DOWN STRAPS
ii - INSTALL LOCKING BOLTS

STEP 1 - INSTALL HEADBOX OR OPEN ROLLER	STEP 2 - INSTALL THE ROLLER TUBE
<p>Refer to the following sections for instructions:</p> <ul style="list-style-type: none"> i - Open Roller install ii - Headbox Install 	<p>Refer to installing the roller section</p>
STEP 3 - INSTALL HOLD DOWN STRAPS	
	
<p>In order to protect the hold down clips, they will be supplied uninstalled from the bottom rail.</p> <p>Remove Bottom Rail end cap</p> <ul style="list-style-type: none"> - Insert ALL Hold down clips with strap, buckle and dog clip attached. - Lower awning to desired fixing height. - Slide hold down clips and straps to desired hold down locations. - Reattach bottom rail end cap. - Fix breaching staple to floor or wall surface under hold down straps. - Use dog clip to attach hold down to breaching staple. 	
STEP 3 ii – INSTALL LOCKING BOLTS TO REVEAL POST	STEP 3 iii - INSTALL LOCKING BOLTS USING BREACHING STAPLE
	
<p>The locking bolts will be supplied pre-installed in the bottom rail</p> <p>Secure to Reveal post</p> <ul style="list-style-type: none"> - Lower awning to desired fixing height. - Slide locking bolts out to desired fixing location - Line up locking bolts with the posts and ensure the bottom rail is level. - Mark fixing holes on post and drill using a 12mm drill bit. - Slide locking bolts into the hole and apply tension to ensure a level installation. - Holes can be drilled at a variety of different stopping locations along the post dependent on consumer requirements 	<p>The locking bolts will be supplied pre-installed in the bottom rail</p> <p>Secure using Breaching Staple</p> <ul style="list-style-type: none"> - Lower awning to desired fixing height. - Slide locking bolts out to desired fixing location - Place breaching staple to floor or wall surface to ensure the locking bolt can be secured under the breaching staple. - Ensure the bottom rail is level. If not, pack out breaching staple to ensure bottom rail will be perfectly horizontal when secured. - Fix breaching staple to floor or wall surface.

ALPHA CABLE GUIDE

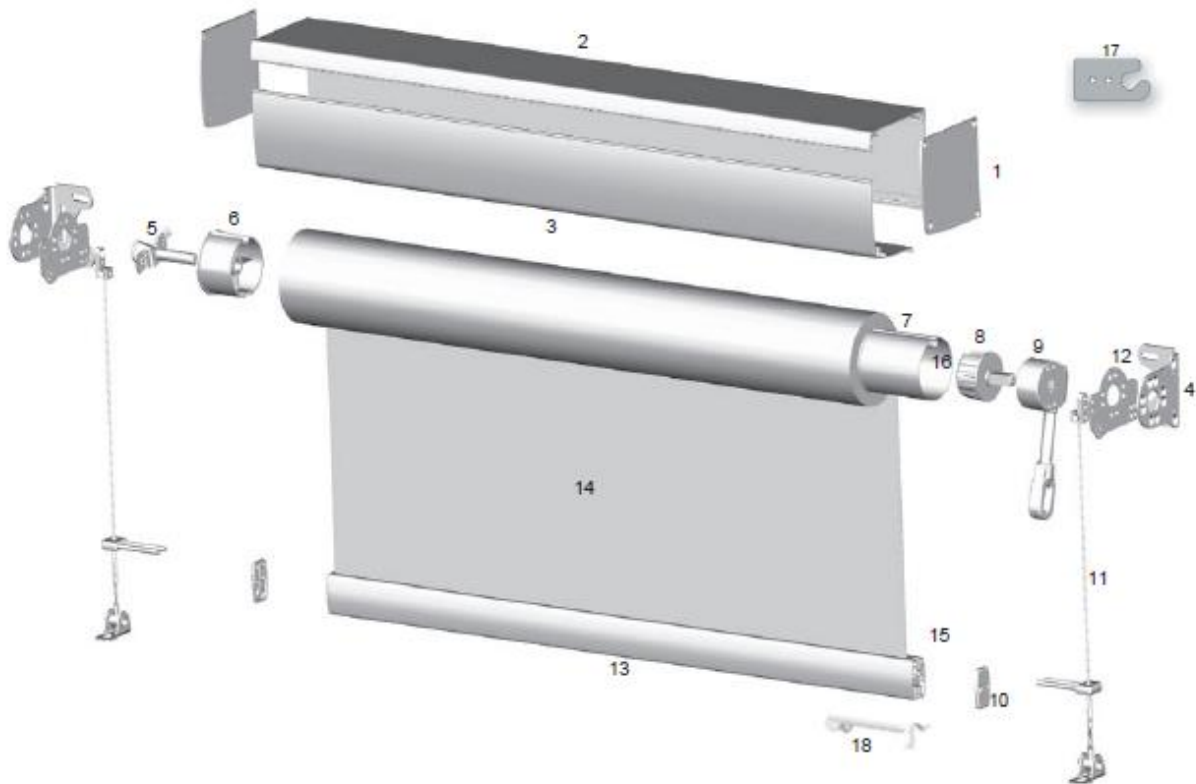

No.	Part No.	Description
1	46.017.000	HEADBOX END CAP LH & RH- MILL
	46.017.100	HEADBOX END CAP LH & RH- SILVER PEARL
2	46.005.000	HEADBOX BACK PLATE- MILL
	46.005.100	HEADBOX BACK PLATE- SILVER PEARL
3	46.012.000	R HEADBOX FRONT COVER- MILL
	46.012.100	R HEADBOX FRONT COVER- SILVER PEARL
4	46.019.000	100MM UNIVERSAL BRACKET Z
	46.019.063	100MM UNIVERSAL BRACKET SS
5	46.002.000	PIVOT PIN & PLATE Z
	46.002.063	PIVOT PIN & PLATE SS
6	46.506.000	60MM IDLE END
	44.210.000	70MM IDLE END
	46.507.000	78MM IDLE END
7	42.180.049	60MM TUBE
	46.522.500	70MM TUBE 5MT
	46.522.700	70MM TUBE 7MT
	46.521.500	78MM TUBE 5MT
	46.521.700	78MM TUBE 7MT
8	42.603.855	60MM DRIVE END - SMALL
	44.209.000	70MM DRIVE END
	46.504.000	78MM CRANK DRIVE END
	46.505.000	60MM DRIVE END - 13MM SHAFT

No.	Part No.	Description
9	42.522.000	4:1 CRANK GEAR MILL
	46.502.100	9:1 GEAR SILVER
	46.502.122	9:1 GEAR WHITE
	46.502.837	9:1 GEAR BLACK
10	46.524.000	PLAIN BOTTOM RAIL END CAP
11	46.107.063	CG CABLE GUIDE SET
12	46.530.063	EXTENSION PLATE
13	46.011.000	R BOTTOM RAIL - MILL
	46.011.100	R BOTTOM RAIL - SILVER PEARL
14	82.296.XXX	CANVAS FABRIC
	44.001.XXX	2.34M EVERVIEW EXTERNAL SCREEN FABRIC
	44.002.XXX	3.2M EVERVIEW EXTERNAL SCREEN FABRIC
15	44.132.000	4.2MM ES SOLID SPLINE
	42.421.855	6MM SPLINE
16	42.198.000	3.5MM HARD SPLINE
	42.421.855	6MM SPLINE
17	46.520.000	HEADBOX REVEAL CLIP
18	46.517.000	R BOTTOM RAIL LOCKING PIN

ALPHA CABLE GUIDE INSTALLATION

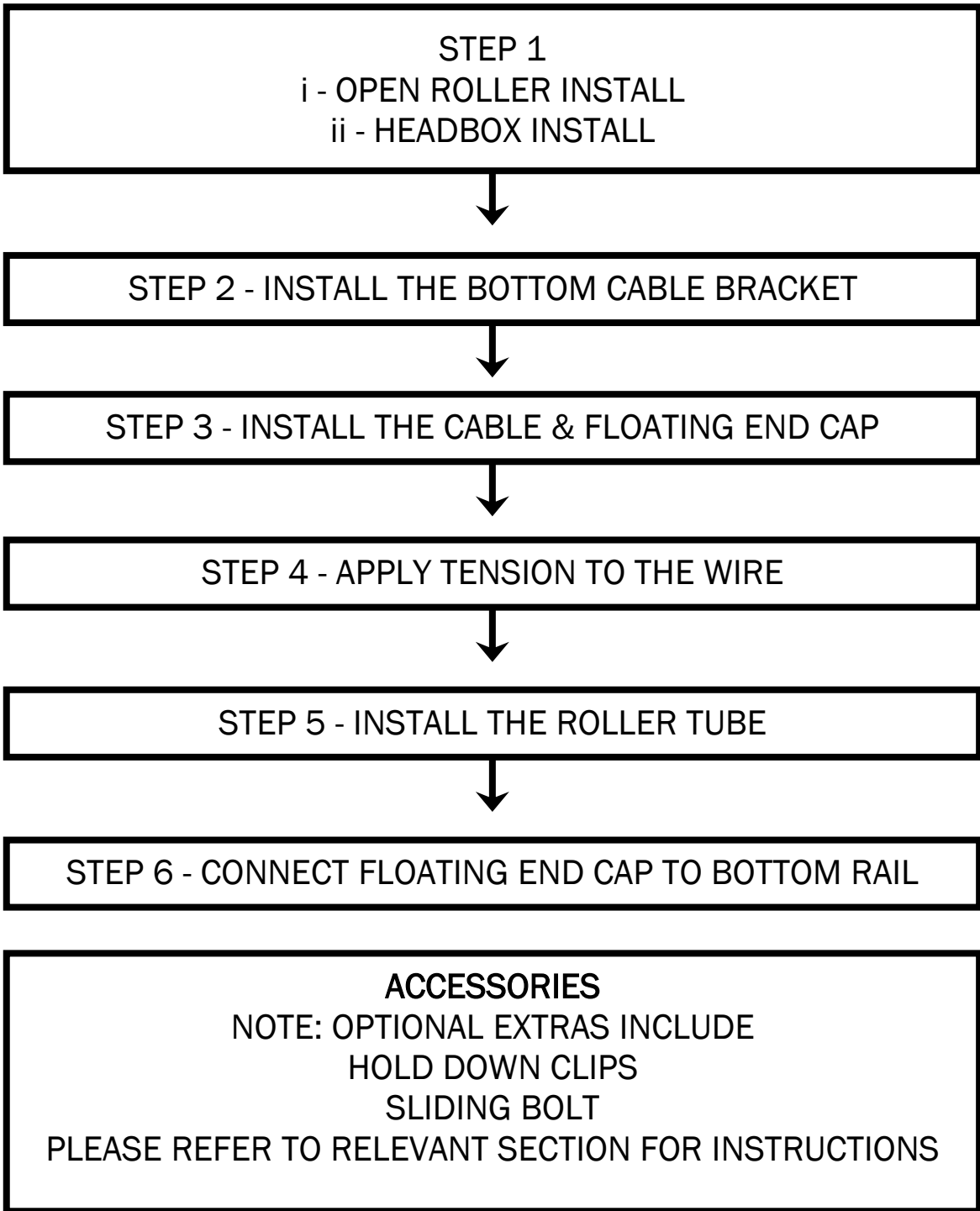

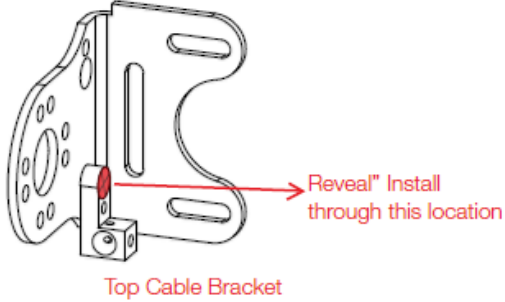
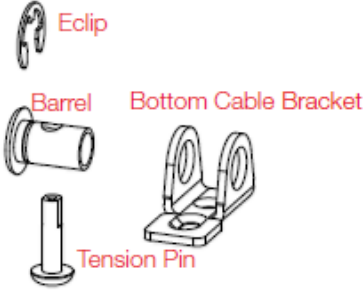
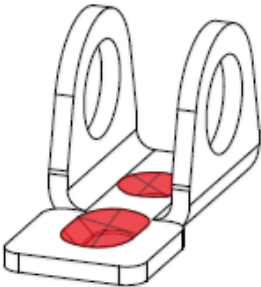
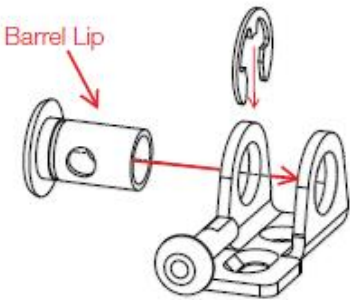
STEP 1 - INSTALL HEADBOX OR OPEN ROLLER	STEP 2 - PREPARE THE BOTTOM CABLE BRACKET
	
<p>Refer to the following sections for instructions</p> <ul style="list-style-type: none"> i - open roller install ii - headbox install <p>NOTE: cable guide installation bracket will come with top cable bracket pre-attached</p>	<p>Use a string line or spirit level from the edge of the blind bracket or side of the headbox to determine the correct location of the wire guide bottom bracket.</p> <p>NOTE: The bottom bracket is universal and can be used for wall, floor or reveal mounting.</p> <ul style="list-style-type: none"> - Remove the Eclip from the barrel using screw driver or pointy nose pliers. - unscrew the bottom tension pin from the bottom of the wire. - remove the barrel from the bracket.
STEP 2 B - INSTALL THE BOTTOM CABLE BRACKET	STEP 2 C - SECURE THE BARREL
	
<p>Place the bottom cable bracket on the location mark and fix into place with the appropriate fixings.</p>	<p>Once bracket is fixed to ground/wall, slide in barrel, ensure the "lip" of barrel is facing towards the awning fabric. Insert the Eclip around the "lip" of the barrel to ensure the barrel is secure.</p>

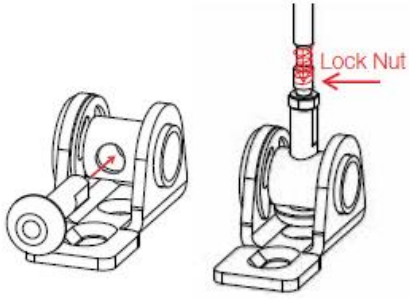
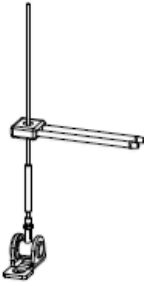
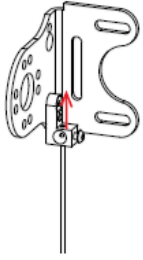
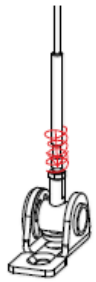
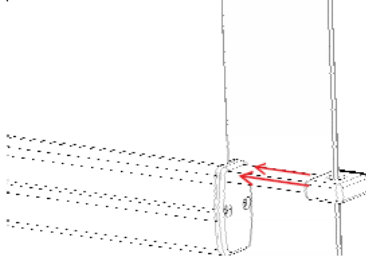
STEP 3 A - ATTACH WIRE TO BOTTOM BRACKET	STEP 3 B - ATTACH FLOATING END CAP TO WIRE
	
<p>Once bracket is fixed to ground/wall, slide in barrel, ensure the "lip" of barrel is facing towards the awning fabric. Insert the Eclip around the "lip" of the barrel to ensure the barrel is secure.</p>	<p>Unwind the wire and feed floating end cap onto the wire.</p>
STEP 4 A - ATTACH WIRE TO TOP CABLE BRACKET	STEP 4 B - APPLY TENSION TO THE WIRE
	
<p>Feed wire through the top cable brackets. Pull the wire tight. Lock off with a 4mm Allen key. Ensure the grub screw is secured tightly.</p>	<p>Return to the bottom bracket and use 2 pairs of pliers to tighten the tension pin by holding the wire with one pair of pliers and turn the pin with the other pair. Repeat on opposite side.</p>
STEP 5 - INSTALL THE ROLLER TUBE	STEP 6 - CONNECT FLOATING END CAP TO BOTTOM RAIL
<p>Refer to installing the roller tube section</p>	 <p>Once the awning is installed lower the awning to a position where it can be reached from the ground. Tilt the awning and insert the floating end cap into bottom rail. Repeat for other side.</p>

ACCESSORIES

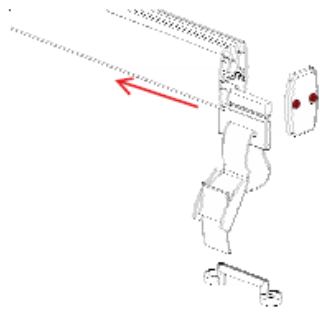

OPTIONAL: HOLD DOWN STRAPS

In order to protect the hold down clips they will be supplied uninstalled from the bottom rail.

- Remove Bottom Rail end cap
- Insert ALL Hold down clips with strap, buckle and dog clip attached.
- Lower awning to desired fixing height.
- Slide hold down clips and straps to desired hold down locations.
- Fix breaching staple to floor or wall surface under hold down straps. Use dog clip to attach hold down to breaching staple

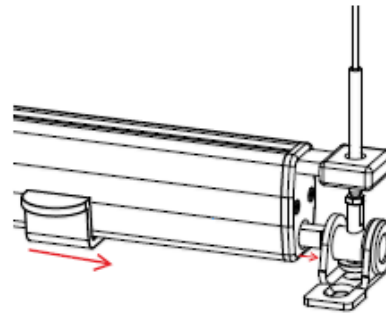

OPTIONAL: LOCKING BOLTS

The locking bolts will be supplied pre-installed to the bottom rail

- Lower awning to the bottom cable guide brackets.
- Slide locking bolts into the bottom cable guide bracket and apply tension to ensure a level installation. If not level, pack out bottom cable guide bracket to ensure bottom rail will be perfectly horizontal when under tension.

ALPHA SIDE TENSION CHANNEL (STC)

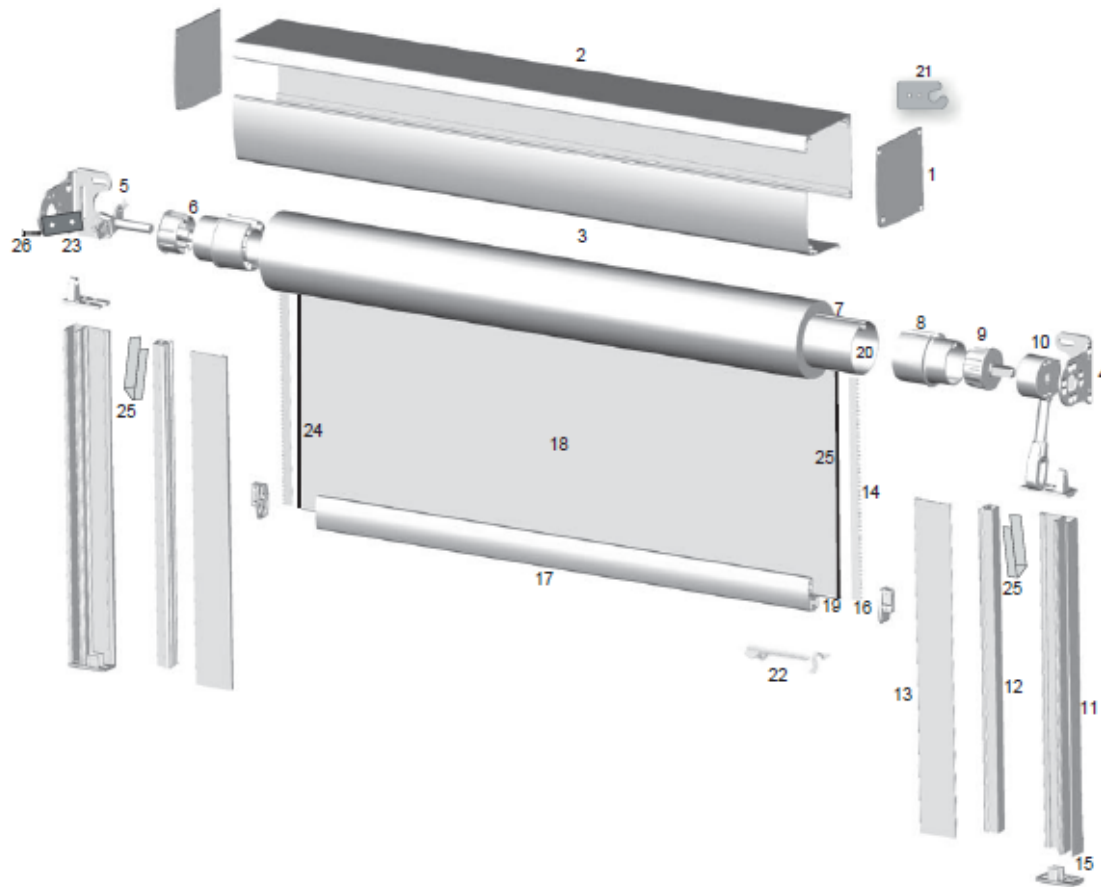

No.	Part No.	Description
1	46.017.000	HEADBOX END CAP LH & RH- MILL
	46.017.100	HEADBOX END CAP LH & RH- SILVER PEARL
2	46.005.000	HEADBOX BACK PLATE- MILL
	46.005.100	HEADBOX BACK PLATE- SILVER PEARL
3	46.012.000	R HEADBOX FRONT COVER- MILL
	46.012.100	R HEADBOX FRONT COVER- SILVER PEARL
4	46.019.000	100MM UNIVERSAL BRACKET Z
	46.019.063	100MM UNIVERSAL BRACKET SS
5	46.002.000	PIVOT PIN & PLATE Z
	46.002.063	PIVOT PIN & PLATE SS
6	46.506.000	60MM IDLE END
	46.521.500	78MM TUBE 5MT
7	46.521.700	78MM TUBE 7MT
	46.306.000	ZS TUBE REDUCER
9	42.603.855	60MM DRIVE END - SMALL
	46.505.000	60MM DRIVE END - 13MM SHAFT
10	42.522.000	4:1 CRANK GEAR MILL
	46.502.100	9:1 GEAR SILVER
	46.502.122	9:1 GEAR WHITE
	46.502.837	9:1 GEAR BLACK

No.	Part No.	Description
11	46.014.000	DC ZS CHANNEL - MILL
	46.014.100	DC ZS CHANNEL - SILVER PEARL
12	46.309.000	ZS FLOATING CHANNEL
13	46.015.000	DC ZS CHANNEL COVER - MILL
	46.015.100	DC ZS CHANNEL COVER - SILVER PEARL
14	46.312.000	ZIP
15	46.016.000	DC ZS CHANNEL END CAP SET
16	46.311.000	ZS BOTTOM RAIL END CAP R
17	46.011.000	R BOTTOM RAIL - MILL
	46.011.100	R BOTTOM RAIL - SILVER PEARL
18	44.001.XXX	2.34M EVERVIEW EXTERNAL SCREEN FABRIC
	44.002.XXX	3.2M EVERVIEW EXTERNAL SCREEN FABRIC
19	44.132.000	4.2MM ES SOLID SPLINE
	42.421.855	6MM SPLINE
20	42.198.000	3.5MM HARD SPLINE
	42.421.855	6MM SPLINE
21	46.520.000	HEADBOX REVEAL CLIP
22	46.517.000	R BOTTOM RAIL LOCKING PIN
23	46.550.000	BLOCK SPACER
24	46.552.855	DURAFOAM TAPE
25	46.551.855	FLOATING GUIDE BRACKET
26	46.553.030	M6X35MM CSK HD PHIL BOLT ZP
	46.553.063	M6X35MM CSK HD PHIL BOLT SS

ALPHA STC INSTALLATION

STEP 1
i - OPEN ROLLER INSTALL
ii - HEADBOX INSTALL

STEP 2 - OPEN THE CHANNEL FRONT COVER

STEP 3 - REMOVAL OF FLOATING GUIDE

STEP 4 - POSITION THE SIDE CHANNEL

STEP 5 - INSTALL THE SIDE CHANNEL

STEP 6 - INSTALL THE ROLLER TUBE

STEP 7 - FEEDING THE FABRIC INTO SIDE CHANNEL

STEP 8 - POSITIONING THE FABRIC AND FLOATING GUIDES

STEP 9 - ATTACHING THE FRONT COVER

ACCESSORIES

NOTE: OPTIONAL EXTRAS INCLUDE
HOLD DOWN CLIPS
SLIDING BOLT

PLEASE REFER TO RELEVANT SECTION FOR INSTRUCTIONS

STEP 1 - INSTALL HEADBOX OR OPEN ROLLER

Refer to the following sections for instructions:
 i - Open Roller install
 ii - Headbox Install

STEP 2 - OPEN THE CHANNEL FRONT COVER

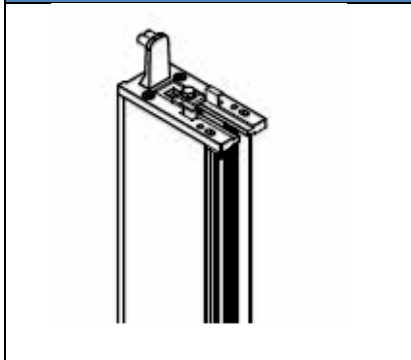

The installation channel will be supplied fully assembled (Back Channel, Floating Channel, Front channel with Top and Bottom channel caps attached).

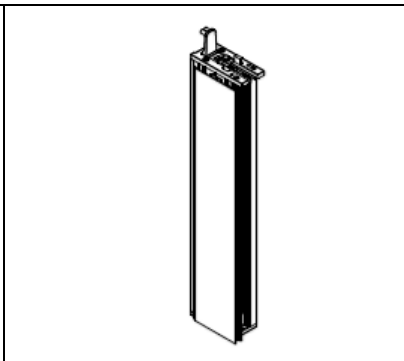
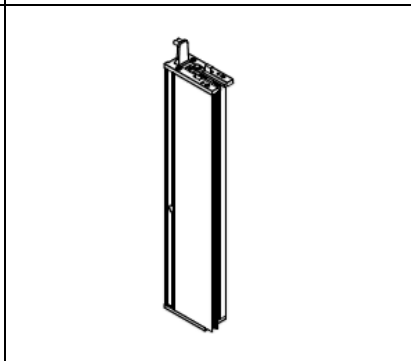
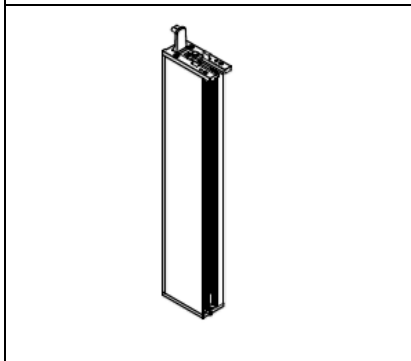

Check if front cover fixing screws at top of bottom end caps are used, if so remove screws.
 Note: An installed awning will have these in place.

Slide front cover towards middle of blind about 12mm where it will stop. This operation can be performed on either end of channel.

Front cover can then be removed by lifting towards user.

STEP 2 – REMOVAL OF FLOATING GUIDE

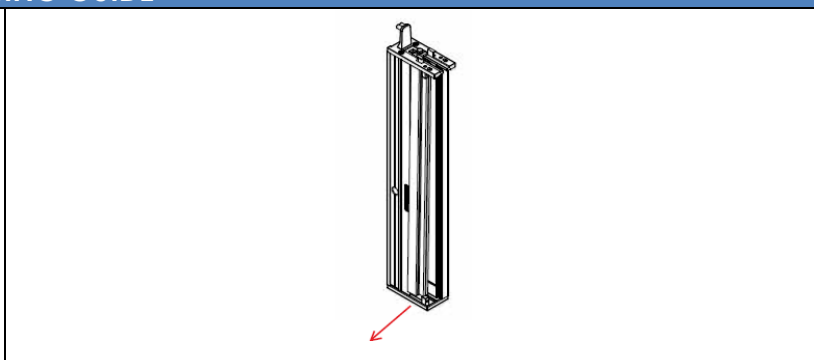

Lift black floating guide towards top of channel about 2mm and tilt bottom guide towards middle of awning.

Pull floating guide towards user and lower guide so bottom end comes out first.
 Note: If this cannot be removed loosen bolt on top end cap.

STEP 4 - POSITION THE SIDE CHANNEL

i) Face Fit with or without headbox

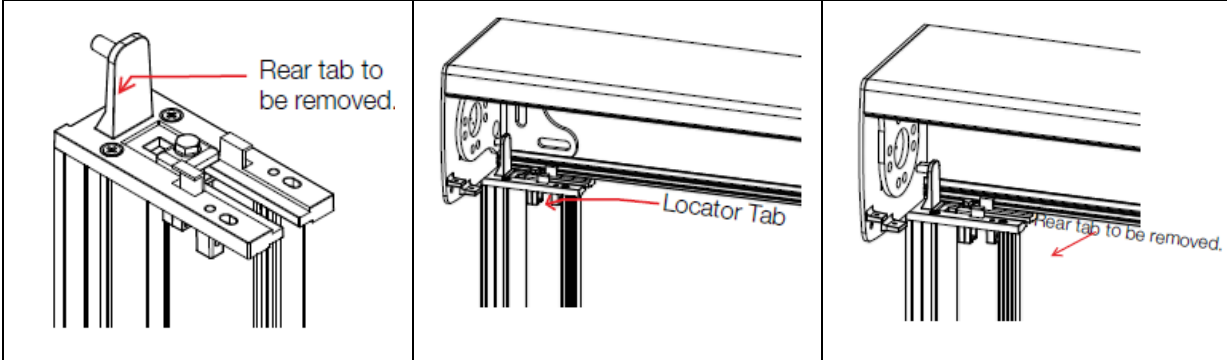

Remove the rear bracket locator tab on the top end cap (if headbox). Remove front bracket locator tab if there is no headbox.

Position the side channel using the remaining bracket locator tab and/or the bottom screw port locator on the top end cap.

ii) Ceiling fit with headbox
No bracket locator tab on the top end cap is used. Position the side channel using the locator tab on the top end cap.

iii) Ceiling fit without headbox

No locator tabs on the top end cap are used.

STEP 5 - INSTALL THE SIDE CHANNEL

i) Face Fit

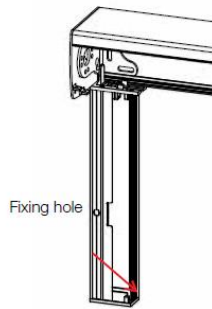

Use a spirit level to ensure channel is vertical and using the fixing holes drill pilot holes for the 25mm fixing screws, then fasten in place. Note: To prevent damage to the channel, when drilling use a bump stop at the end of the drill.

ii) Reveal Fit

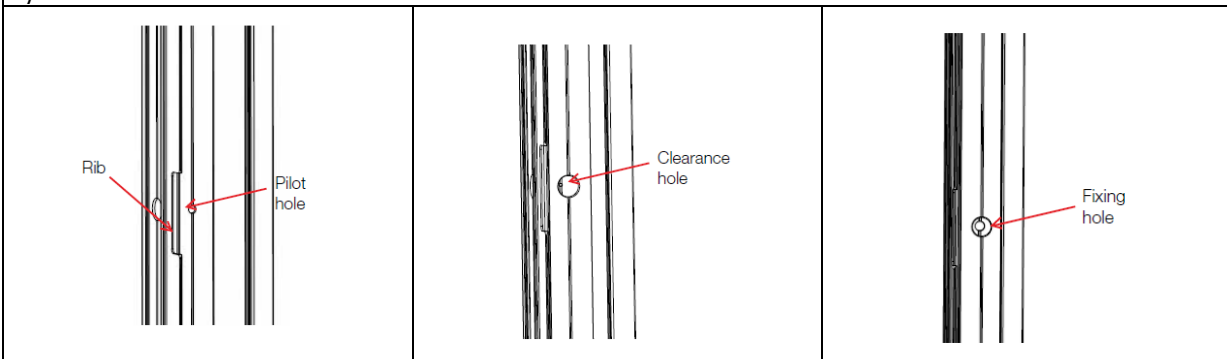

a) Drill pilot holes on the middle rib at the same intervals as the face fixing

b) Drill the screw head clearance hole at same locations above and

c) Use spirit level to ensure channel is vertical and drill pilot fixing hole through

holes on the side channel back plate.	continue through middle rib to make centre mark for force fixing hole.	the back plate and the wall so the fixing screws (self-drilling) can be used, then fasten in place.
---------------------------------------	--	---

STEP 6 - INSTALL THE ROLLER TUBE

Refer to installing the roller section

1) Check side channels are parallel

STEP 7 - FEEDING FABRIC INTO SIDE CHANNEL

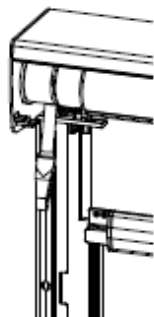

a) Lower the awning 100mm from top and feed fabric through the top channel cap

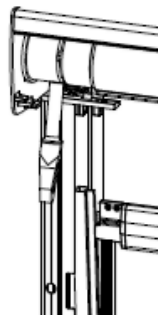

b) Feed fabric into floating guide and slide up (Step 3 in reverse).
c) Make sure floating guide is fitted onto top end cap locator. There should be no more than 5mm between the top end cap and the floating guide when resting on the bottom end cap.

STEP 8 - POSITIONING THE FABRIC AND THE FLOATING GUIDES

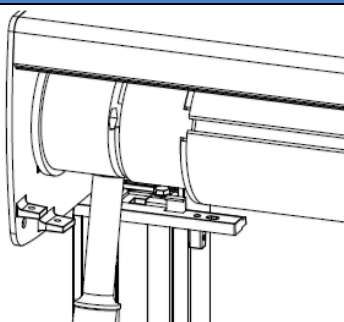

) Fully Lower and raise the blind to align the floating guides. While performing this, check the skin is centred on the awning. The edge of the skin must be close to the same position on both reducers on the tube. If not, remove skin and roller tube, re-centre then repeat alignment of floating guides. After lowering and raising skin tighten top end cap locating nut.

b) With the skin lowered, fix the floating guide at the lowest point possible by:

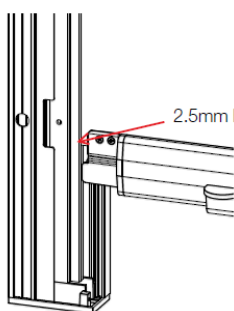

i) Pulling floating guide so fabric is just flat between the bottom rail cap and

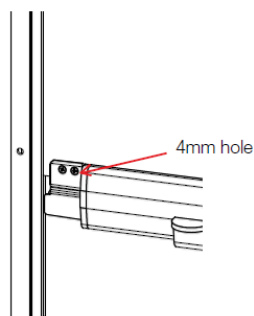

ii) Drill a 4mm hole through the 2.5mm pilot hole.

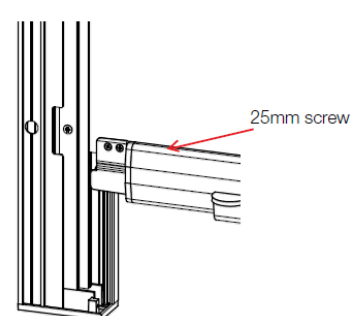

<p>the channel, drill a 2.5mm hole through the floating guide and the fixing plate. Warning: Ensure you do not drill through the whole back plate.</p>	<p>iii) Fasten the 25mm countersunk screws into floating guide and channel so the head of the screw is no more than 1mm proud of the other floating guide.</p>
--	--

iv) Repeat the steps above on the other side.

c) Repeat the process using the fixing hole closest to the middle of the side channel.

d) Raise and lower skin to check operation, adjust tension if required by repositioning floating guide.

e) • Check the bottom rail for levelness. A tolerance of 5 to 6mm is acceptable.
• If bottom rail level is not within tolerance, roll the awning to the fully down position. Then continue unrolling the blind so the fabric balloons out from the tube and till you have access to the spline section of the skin.
• Pull the skin in the direction of the side of the bottom rail that is up. Move the skin 1 to 2mm then raise the awning to check for bottom rail evenness.
• Repeat above process if required.

STEP 9 - ATTACHING THE FRONT COVER

a) Raise skin so bottom rail is within 100mm of top end cap.

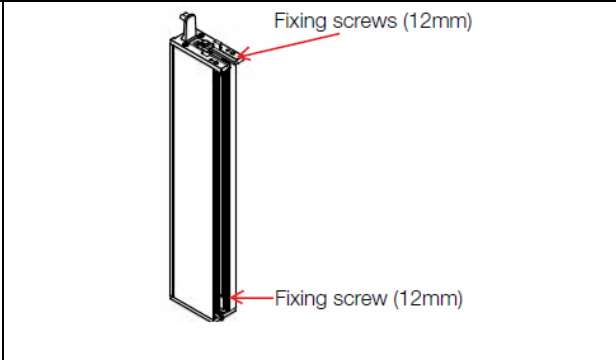
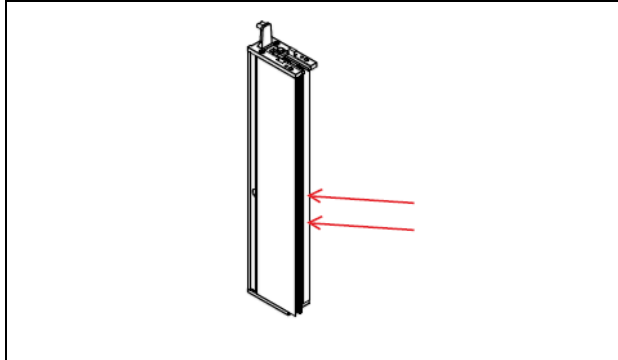

b) Align front cover on back plate so face is flush with side channel outer surface then slide into position.

c) Fasten the front cover into position by fixing the screws with a screwdriver through the front cover at the top of the bottom end caps.

ACCESSORIES

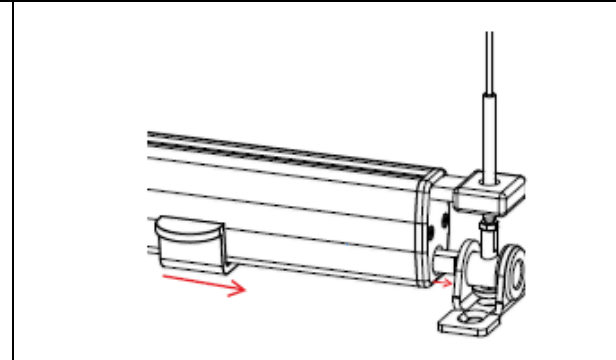
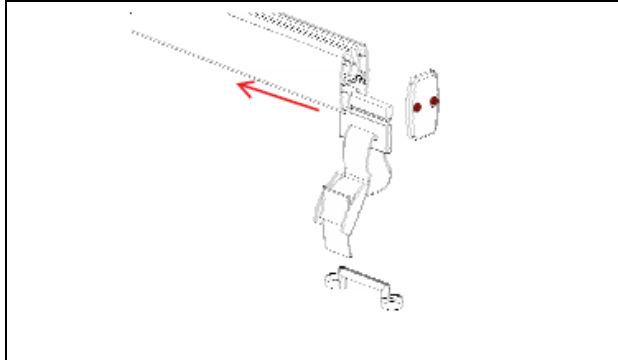

OPTIONAL: HOLD DOWN STRAPS

These instructions relate to fixing hold down straps to other guiding options. In order to protect the hold down clips, they will be supplied uninstalled from the bottom rail.

- Remove Bottom Rail end cap
- Insert ALL Hold down clips with strap, buckle and dog clip attached.

OPTIONAL: LOCKING BOLTS

The locking bolts will be supplied pre-installed to the bottom rail

- Lower awning to the bottom cable guide brackets.
- Slide locking bolts into the bottom cable guide bracket and apply tension to ensure a level installation. If not level, pack out bottom cable

<ul style="list-style-type: none">- Lower awning to desired fixing height.- Slide hold down clips and straps to desired hold down locations.- Fix breeching staple to floor or wall surface under hold down straps.- Use dog clip to attach hold down to breeching staple.	<p>guide bracket to ensure bottom rail will be perfectly horizontal when under tension.</p>
---	---

ALPHA PIVOT ARM

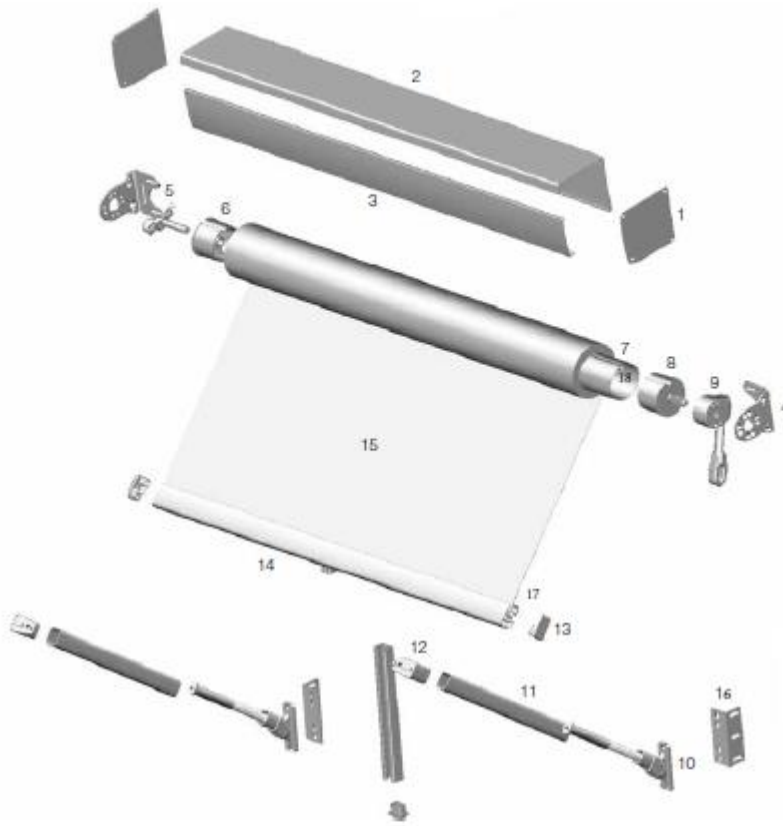

No	Part	Description
1	46.606.XXX	HEADBOX END CAP LH & RH
2	46.006.XXX	HEADBOX BACK PLATE
3	46.012.XXX	R HEADBOX FRONT COVER (CLOSED)
	46.013.XXX	R HEADBOX FRONT COVER (OPEN)
4	46.019.XXX	100MM UNIVERSAL BRACKET
5	46.002.XXX	PIVOT PIN & PLATE
6	46.506.000	60MM IDLE END
	44.210.000	70MM IDLER WITH HOLE
	46.507.000	78MM IDLE END
	42.180.049	60MM TUBE
7	46.522.500	70MM TUBE 5MT
	46.522.700	70MM TUBE 7MT
	46.521.500	78MM TUBE 5MT
	46.521.700	78MM TUBE 7MT
8	42.803.855	60MM DRIVE END - SMALL
	44.209.000	70MM DRIVE END
	46.504.000	78MM CRANK DRIVE END
	46.506.000	60MM DRIVE END - 13MM SHAFT

No	Part	Description
9	46.502.XXX	9:1 GEAR
10	46.423.100	PA ARM BRACKET
11	46.421.000	PA ARM PROFILE
12	46.422.030	PA FRONT RAIL CONNECTOR
13	46.420.000	PA FRNT RAIL END CAP
	46.419.XXX	R PA FRONT RAIL
15	82.29X.XXX	CANVAS FABRIC
	44.30X.XXX	EXTERNAL SCREEN FABRIC
16	46.416.100	PA ANGLE BRACKET (SIDE FIX)
17	44.132.000	4.2MM ES SOLID SPLINE
	42.421.855	6MM SPLINE
80	42.198.000	3.5MM HARD SPLINE
	42.421.855	6MM SPLINE

ALPHA PIVOT ARM INSTALLATION

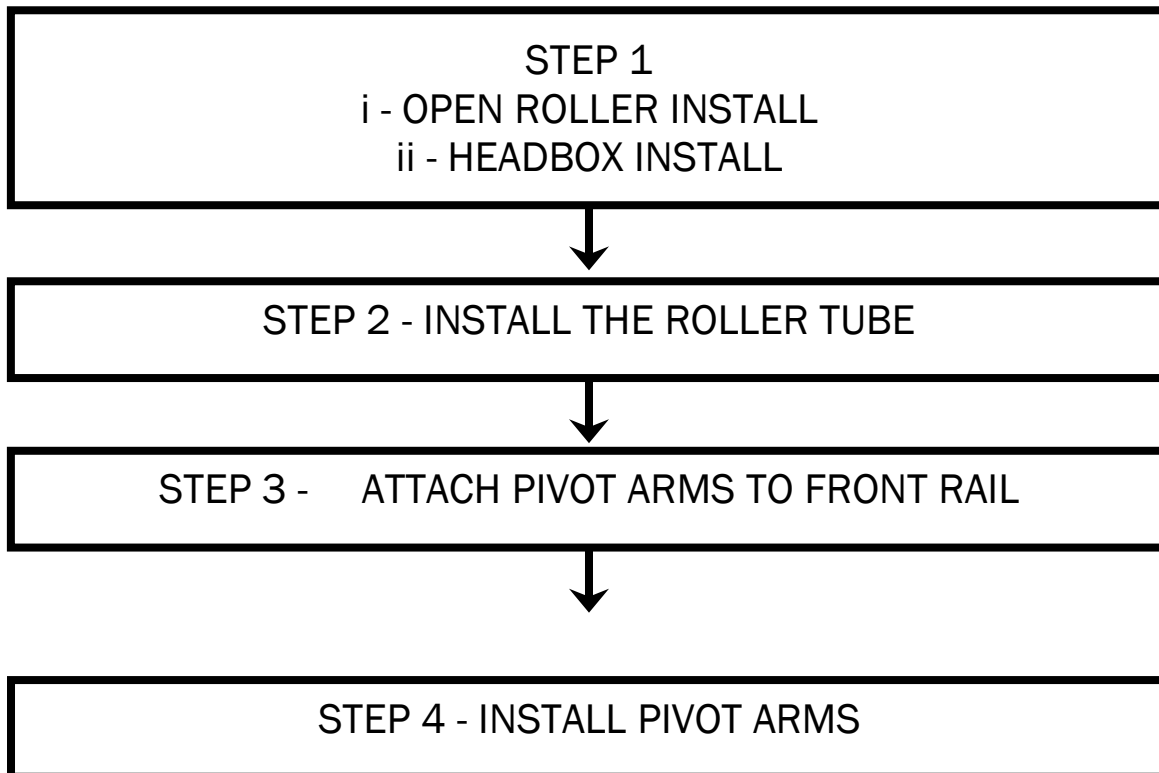

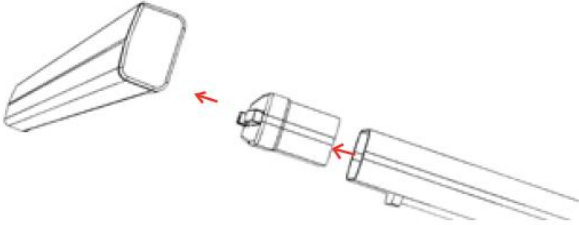
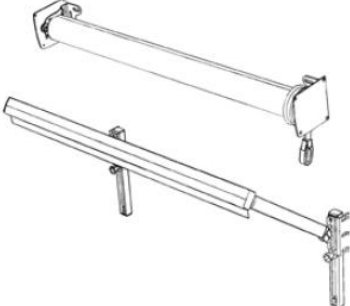
STEP 1 – INSTALL HEADBOX OR OPEN ROLLER	STEP 2 - INSTALL THE ROLLER TUBE
<p>Refer to the following sections for instructions</p> <ul style="list-style-type: none"> i - open roller install ii - headbox install 	<p>Refer to installing the roller section</p>
STEP 3 - ATTACH PIVOT ARMS TO FRONT RAIL	STEP 4 - INSTALL PIVOT ARMS
	
<p>Attach pivot arms to front rail NOTE: Arms should be positioned within 300mm of the ends of the bottom rail and should be of equal distance.</p>	<p>Lower front rail 20mm below headbox or brackets and ensure the tube and front rail are parallel.</p> <ul style="list-style-type: none"> - Mark fixing location of pivot arm installation foot. - Install pivot arms using screws. <p>NOTE: For ALPHA Pivot Awning Reveal installations an angle bracket will be provided to mount the pivot arm foot to. The location of the angle bracket can be determined using the above process.</p>

OPERATING INSTRUCTIONS

Manual Operation of the awnings with Crank

To extend the awning:

- Insert end of crank handle into the drive gear winding mechanism.
- Rotate crank clockwise until awning is fully extended. (Do not keep winding once resistance is felt).

It is then recommended that you turn the crank anti clockwise slightly to reduce tension.

To retract the awning:

- Insert end of crank handle into gear winding mechanism.
- Rotate anti-clockwise until awning is fully retracted.
(Do not keep winding once resistance is felt.)

Warning!

Watch the screen fabric carefully when retracting the awning to ensure there are no obstructions or creasing of the fabric. Should any resistance be felt or visible signs of the fabric not rolling up straight, stop immediately and turn crank in opposite direction until fabric is clear and runs smoothly, then start retracting again slowly.

Automation Operation of the awnings with Remote

To extend the awning:

- Press the appropriate button on the remote control.
- The awning will extend until it reaches the preset fully extended position.
- The motor will stop automatically.

To retract the awning:

- Press the appropriate button on the remote control.
- The awning will retract until it reaches the preset fully retracted position.
- The motor will stop automatically.

Warning!

For automatic operating awnings or accessories, please ensure these are switched off during periods of absence (e.g. holidays) or when the awning will be left unattended.

FULL BRICK ON FACE/BRICK VENEER

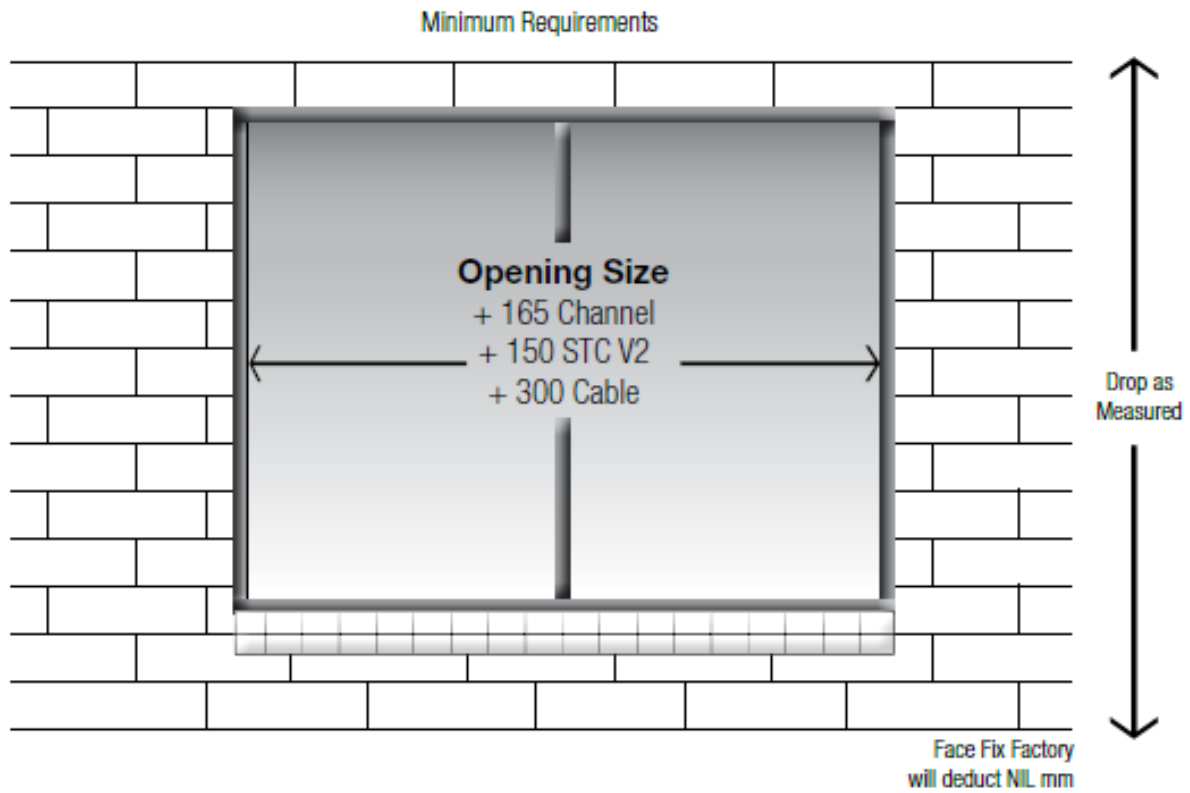

Side Tension Channel Dimensions 73 x 37.5mm

ON FACE ARCHITRAVE

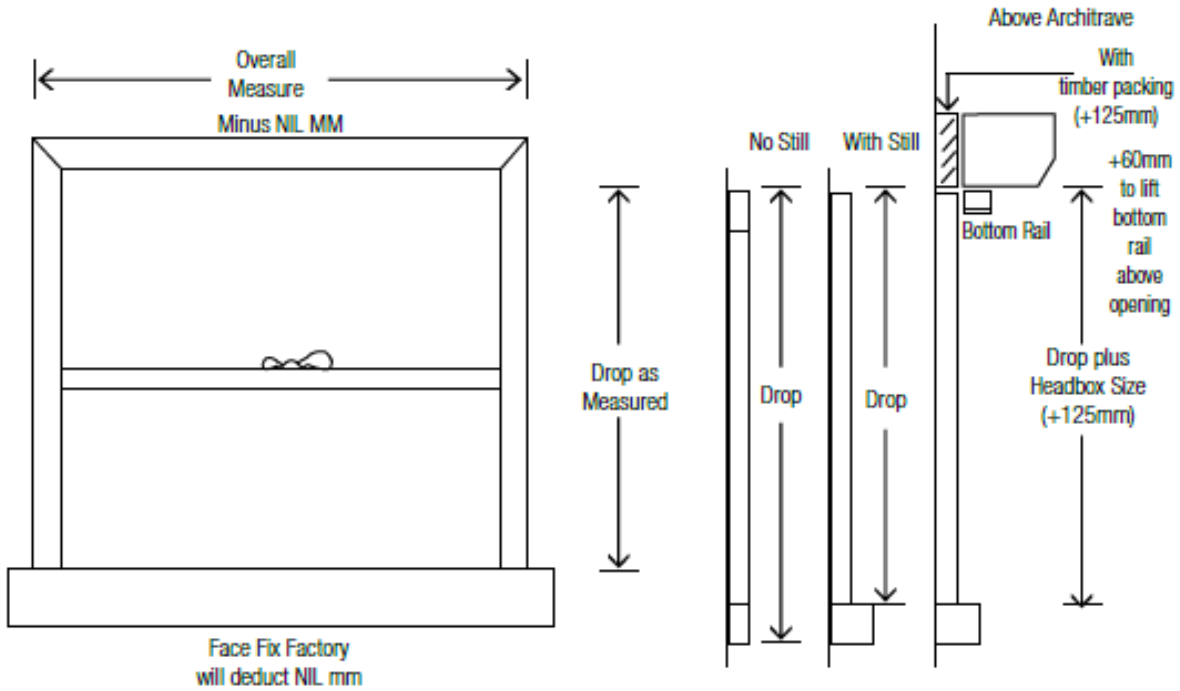

REVEAL & TOP FIX (SIDE FIX)

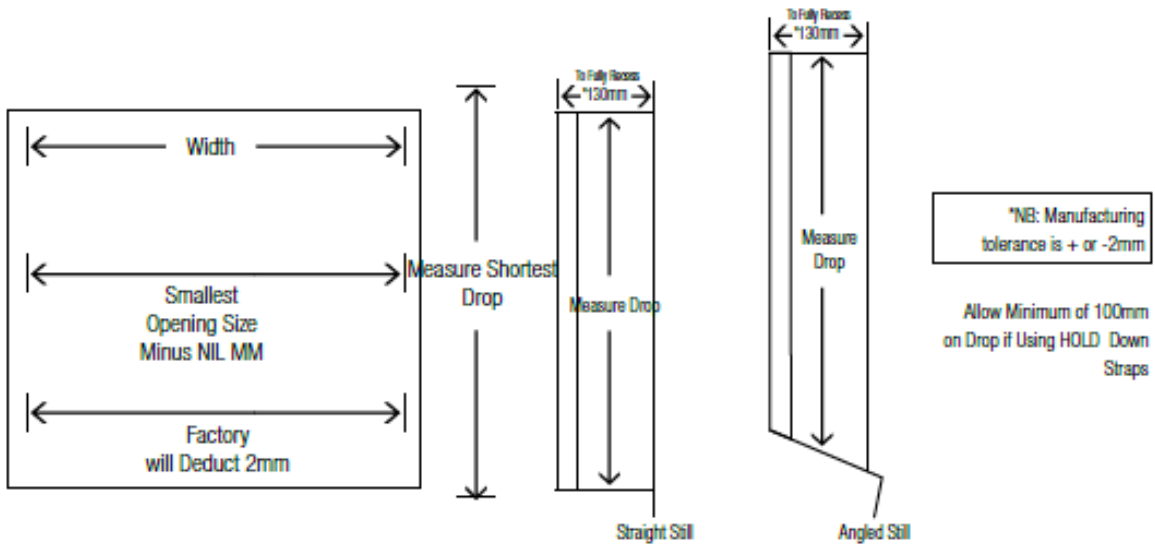

Headbox Dimensions are

Projection= 130mm

Drop = 125mm

Bracket Dimensions are

Drop = 100mm

Projection= 100mm

Width= 68mm